



**ROSE**

A Phoenix Mecano Company



# OPERATING AND DISPLAY ENCLOSURES

2023



In 1969 ROSE Systemtechnik GmbH was founded in Porta Westfalica, Germany. Today ROSE is one of the world's leading and innovative providers of industrial enclosure system engineering, employing over 350 people at the German headquarter.

In association with Phoenix Mecano AG, Switzerland, we develop and manufacture high-quality industrial enclosures and system solutions for areas such as mechanical and plant engineering, automation engineering, potentially explosive atmospheres, instrumentation, control and automation technology, as well as the foodstuff and beverage industry.

Our product range comprises the following:

- Standard industrial enclosures made of aluminium, stainless steel and plastics for individual installations of electrical connection technology and electronic components.
- Operating and display enclosures based on aluminium profile systems and stainless steel materials for HMI applications with industrial PCs, PLC control systems and visualization units, including suspension systems.
- Components for explosion protection with junction boxes and control stations for worldwide use in potentially explosive atmospheres, as well as the petrochemical and chemical industry in both onshore and offshore environments.

Our business success is based on a wide range of products, a high quality standard, constant innovation and an exceptional level of service. You decide the condition of delivery – the un-machined enclosure, a partial assembly or a completely assembled and tested customized system solution.

Take advantage of our worldwide sales and marketing network for your international projects.





Due to their variable profile structure, ROSE operating and display enclosures are flexible in terms of height and width.

A wide selection of different profile depths offers the required space for your installations.

ROSE suspension systems made of aluminium profile offer the same flexibility.

They are available in both standard and customised lengths.

Your benefit: we provide you with your customized solution starting at 1 item - quick, cost effective and reliable.

You decide what we can do for you!

We offer you all the options – from individual components, to completely assembled and fitted combinations of operating enclosures and suspension systems.



Individual Executions based on your CI concept are no problem for us.

We would be pleased to support you - starting with the design up to the complete system, including testing and approval.

Our operating and display enclosures and suspension systems correspond to the current state of technology. Furthermore, our operating enclosures show all necessary approvals including UL approval for use in the US. Our enclosures are listed in almost all operating equipment regulations of renowned automotive manufacturers both within Germany and worldwide.



# Content

	Page		Page		
	<b>SL 5000</b> The new flexible and modular control enclosure	10		<b>Commander 420</b> Stainless steel control enclosure for industrial areas	61
	<b>SL 4000</b> Control enclosure system for automation engineering	15		<b>Commander 450</b> Stainless steel control enclosure for industrial areas	63
	<b>SL 3000</b> Universal control enclosure system for automation technology	26		<b>Commander system accessories</b> Components for operating enclosures	65
	<b>SL 2000</b> Enclosure system for control and display fittings	35		<b>Heat management</b> Climatic systems for Commander	77
	<b>ComTronic</b> Aluminium profile compact Commander	40		<b>GTK electronic</b> Suspension system with free accessible cable channel for low loads	82
	<b>Commander 1</b> Small control enclosure system made of diecast aluminium	46		<b>GTS</b> Aluminium suspension system for low and middle loads	89
	<b>Commander 1F</b> Small control enclosure system in aluminium with front frame for front panels and keypads	52		<b>GTN II</b> Aluminium suspension system with closed or freely accessible cable duct for middle and heavy loads	99
	<b>Commander KSSC</b> Stainless steel control enclosure	57		<b>GTL</b> Heavy load suspension system	113
	<b>Commander 410</b> Stainless steel control enclosure	59		<b>Flat Panel Adapter</b> Addition to suspension systems	119

Technical modifications reserve!



	Page		Page		
	<b>GTV light</b> Height adjustment system	123		<b>Taguan 130</b> ABS hand held enclosure for data acquisition and instrumentation	182
	<b>GTV 2.0</b> Height adjustment system	126		<b>Taguan 180/230</b> ABS hand held enclosure for data acquisition and instrumentation	187
	<b>GTH 48 / GTH 60</b> <b>GTH 48 easy / GTH 60 easy</b> Stainless steel round tube system with system components	130 137		<b>Beluga 180/220</b> Polyamide hand held enclosure for MCR- and automation engineering	193
	<b>GT 48/2</b> Industrial round tube suspension system	144		<b>Beluga 380</b> Polyamide hand held enclosure for MCR- and automation engineering	197
	<b>GT 50/2, GT 60/2, GT 80/2</b> Industrial square tube suspension system	152		<b>Pilot 250</b> Polyamide hand held enclosure for MCR- and automation engineering	200
	<b>GTK 80</b> Industrial square suspension system with free accessible cable channel for heavy control and display equipment	160		<b>Pilot 50</b> Polyamide/PVC hand held enclosure for MCR- and automation engineering	203
	<b>Moterm I + II</b> Mobile stand system for control components	166		<b>Pilot 10/20/30</b> Hand held enclosure for MCR- and automation engineering	207
	<b>Inclining adapter</b> Inclining adapter for individual connections between enclosures and ROSE suspension systems or for wall mounting	174		<b>Pilot 110-150</b> Polyamide hand held enclosure for automation and control engineering	210
	<b>Limanda</b> Polyamide handheld enclosure system for MCR, automation technology and data acquisition	178		<b>Electro-mechanical components</b>	214



# General technical information

---

## Enclosure selection criteria

Enclosures are generally required to protect the installed equipment from external hazards. These hazards can be varied in nature and are of decisive significance when determining the criteria for the choice of an enclosure. Essential for appraising whether an enclosure meets safety requirements is a precise definition of the hazards expected at an installation location. The most important conditions to consider are the following:

1. Protection against contact and penetration of foreign bodies
2. Protection against water penetration
3. Protection against internal and external radio interference
4. Chemical resistance
5. Temperature stability
6. Impact resistance
7. Corrosion resistance

### Enclosure ratings

ROSE enclosures are classified in enclosure rating in accordance with the generally applicable guidelines contained in EN 60529 and IEC 144.

The enclosure rating is indicated by an abbreviation, which is always composed of the two letters IP and two digits relating to the protection level.

### Protection class for contact and foreign bodies protection

First digit	Designation
0	No protection
1	Protection against large foreign bodies
2	Protection against medium-sized foreign bodies
3	Protection against small foreign bodies
4	Protection against granular foreign bodies
5	Protection against dust deposits
6	Protection against dust entry

### Water protection class

Second digit	Designation
0	No protection
1	Protection against vertical falling drip water
2	Protection against obliquely falling drip water
3	Protection against water spray
4	Protection against splashing water
5	Protection against water jets
6	Protection when flooded
7	Protection when immersed
8	Protection when submerged

Note: The enclosure ratings given apply to unmodified enclosures as supplied. Wear and tear and temperature fluctuations may lead to a reduction in the enclosure rating.

### Temperature stability

The definition of temperature stability for enclosures is based on the maximum continuous temperature at which the enclosure remains dimensionally stable and the enclosure rating remains guaranteed. The permissible brief peak temperatures are often considerably higher.

### Corrosion resistance of aluminium enclosures

The corrosion resistance of aluminium enclosures is rated as good, even without special surface treatment. The use of special aluminium alloys with low copper content increases the corrosion resistance.

Additional treatments including

- chromating
  - lacquering (powder coating) and
  - the combination of chromating and lacquering
- further increase corrosion resistance.

### We offer the following for critical external areas:

SWB Execution (seawater-resistant):  
Purified - chromated - powder-coated  
Standard colour RAL 5009, other colours on request.

For application areas with extreme UV radiation we recommend coating with a special Polyester powder.

SBG/SBGL Execution only for wet painting processes

SBG = Purified - alodine-primed

SBGL = Purified - alodine-primed - painted



## Chemical resistance enclosure materials

Chemicals	Aluminium	Stainless steel	Polycarbonate	Polyester	Polystyrene	Polyamide
Acetone	+	+	-	-	-	•
Formic acid	•	+	30 %	10 %	•	-
Ammonia	+	+	-	-	+	20 %
Petrol	+	+	•	+	•	+
Benzene	+	+	-	+	-	-
Brake fluid	/	/	-	+	/	60°
Butane	+	/	+	/	-	+
Butanol	/	/	/	+	/	+
Calcium chloride	+	+	+	+	+	+
Chloral benzene	+	/	-	+	-	•
Diesel öoil	/	/	•	+	•	/
Vinegar	+	+	10 %	40 %	+ max. 50 %	-
Formaldehyde	+	+	/	30 %	+ max. 40 %	+
Freon 113	/	/	+	+	/	/
Fruit juice	/	+	+	+	/	+
Glycerine	+	+	•	+	+	+
Fuel oil	+	+	•	+	•	+
Hydraulic oil	/	/	+	+	•	+
Caustic potash solution	/	+	-	-	+ max. 50 %	-
Potassium chloride	•	+	+	+	+	+
Potassium hydroxide	-	+	/	-	+	/
Linseed oil	+	+	+	+	+	+
Methane	+	+	-	-	+	•
Methylene chloride	+	+	-	-	-	-
Lactic acid	+	+	10 %	+	+ max. 80 %	10 %
Mineral oils	/	/	+	+	+	+
Motor oils	/	/	+	+	+	+
Sodium carbonate	•	+	+	+	+	+
Sodium chloride	•	•	+	+	+	10 %
Sodium hydroxide	+	+	/	-	/	/
Soda lye	/	+	-	40 %	+ max. 50 %	10 %
Nitric acid	+	+	10 %	10 %	+ max. 25 %	-
Hydrochloric acid	/	+	20 %	+	+ max. 10 %	-
Lubricating oil	+	+	+	+	/	+
Carbon toulphide	+	+	-	-	-	•
Sulphuric acid	•	+	50 %	70 %	+ max. 50 %	-
Suds	/	+	•	+	/	+
Cleansing agent	/	+	+	/	/	/
Terpentine oil	/	/	/	+	-	+
Carbon tetrachloride	+	/	/	+	-	•
Toluene	+	/	-	+	-	+
Trichlorethylene	+	/	/	-	-	-
Water (dest. water, river-, / mains-, sea water)	/	+	+	+	+	+
Tartaric acid	/	/	10 %	+	+	+
Xylene	+	/	-	+	-	+
Zinc sulfate	•	/	+	+	+	/
Citric acid	+	/	10 %	+	+	10 %

The investigations, unless stated otherwise, were carried out at room temperature. Resistances can vary when two different materials come into contact with one another. We cannot therefore accept liability for this data.

### Explanation of symbols

- + resistant to all concentrations
- % resistant against maximum % concentration
- C° resistant to maximum C°
- limited resistance
- not resistant
- / no information

# General technical information

## Chemical resistance enclosure seals and accessories

Chemicals	Chloroprene	EPDM	NBR	Pocane	Polyurethane	PVC	Silicone
Acetone	+	+	-	+	-	-	•
Formic acid	+	+	-	10 %	/	< 50 %	•
Ammonia	+	+	+	10 %	/	•	+
Petrol	+	•	+	+	+	+	+
Benzene	-	-	-	+	+	-	-
Brake fluid	•	-	/	+	/	/	+
Butane	+	/	+	+	/	50 %	-
Butanol	+	/	-	+	/	•	-
Calcium chloride	/	/	/	10 %	/	+	/
Chloral benzene	-	-	-	-	-	-	-
Diesel oil	•	•	/	+	+	•	•
Vinegar	-	/	-	10 %	/	25 %	-
Formaldehyde	-	/	+	/	/	40 %	+
Freon 113	+	/	+	+	/	/	/
Fruit juice	+	+	/	+	+	+	+
Glycerine	+	+	+	+	+	+	+
Fuel oil	•	•	+	+	+	•	•
Hydraulic oil	+	/	/	+	/	/	•
Caustic potash solution	+	/	/	10 %	/	+	/
Potassium chloride	+	+	+	10 %	+	+	+
Potassium hydroxide	+	+	+	-	-	/	•
Linseed oil	+	+	+	+	+	+	•
Methane	+	/	•	+	/	/	+
Methylene chloride	-	/	-	-	-	-	-
Lactic acid	+	+	+	/	/	10 %	/
Mineral oils	•	•	+	+	+	+	+
Motor oils	•	•	+	+	+	/	+
Sodium carbonate	/	/	/	10 %	/	/	/
Sodium chloride	+	+	+	10 %	+	+	+
Sodium hydroxide	+	+	•	-	-	•	•
Soda lye	50 %	/	-	/	/	60 %	-
Nitric acid	•	+	•	10 %	-	30 %	-
Hydrochloric acid	+	+	< 65 % •	10 %	-	30 %	/
Lubricating oil	•	•	+	+	+	+	+
Carbon toulphide	-	/	-	+	/	•	-
Sulphuric acid	50 %	/	25 %	10 %	/	80 %	25 %
Suds	+	/	+	10 %	•	•	+
Cleansing agent	+	•	/	+	•	/	+
Terpentine oil	-	/	+	+	/	+	-
Carbon tetrachloride	-	-	-	+	-	•	-
Toluene	-	-	-	•	-	-	-
Trichlorethylene	-	-	-	•	-	-	-
Water (dest. water, river-, mains-, sea water)	+	+	80 C°	+	+	40 C°	+
Tartaric acid	+	+	+	/	+	10 %	+
Xylene	-	-	-	•	-	-	-
Zinc sulfate	+	+	+	/	/	40 %	+
Citric acid	+	+	+	10 %	/	10 %	+

The investigations, unless stated otherwise, were carried out at room temperature. Resistances can vary when two different materials come into contact with one another. We cannot therefore accept liability for this data.

### Explanation of symbols

- + resistant to all concentrations
- % resistant against maximum % concentration
- C° resistant to maximum C°
- limited resistance
- not resistant
- / no information



## General

In electronic engineering, enclosures are required to fulfil two tasks:

- to protect equipment against external mechanical hazards and radio interference
- to protect the environment against mechanical and electrical hazards or radio interference caused by equipment

Electromagnetic compatibility (EMC) is becoming an increasingly important factor in the choice of enclosures due to sustained advances in the development of electronic components and increased density of components on circuit boards - this being connected with increased emission of electromagnetic radio interference into the environment.

## Statutory regulations

The Electromagnetic Compatibility guideline Act (EMC) had been revised on 14 December 2016 and transposes the 2014/30/EU Directive on electromagnetic compatibility into German law.

The law applies to equipment that can cause electromagnetic interference or whose operation can be impaired by electromagnetic interference.

According to § 4 - Basic requirements - these equipment must be designed and manufactured in accordance with the generally recognised rules of technology in such a way that the following two conditions are met: Firstly, the electromagnetic disturbances caused by the equipment must not render the operation of other equipment impossible. Secondly, the equipment itself must be sufficiently insensitive to interference from other equipment.

## Enclosure requirements

Enclosures in themselves are not covered by the EMC legislation as they are not by definition electrical or electronic devices.

Enclosures are however largely responsible for the strength of radiation emissions and/or interference (outgoing or incoming interference) of a device. The enclosure material is also a decisive factor in the screening effect, which is the combined reflection and absorption damping properties of an enclosure.

Plastics alone have no filtering effect in the case of radio interference. Screening characteristics can be achieved with additional expensive treatments (metal vaporisation or the application of a conductive coating).

Metal enclosures on the other hand offer a highly effective basic protection against radio interference without any further treatment. Large surface area contact of individual enclosure parts (cover, enclosure sections) is an important factor in this.

Where special safety requirements exist, EMC compatibility can be increased by

- conductive seals,
- contact-uninsulated ends and
- EMC-compliant cable connections.



- + Individual dimensions and design in length and width
- + Lateral integration of fixtures, i.e. EKS system
- + Desk connection
- + Optional accessories, i.e. external handles or indicator lights

Due to its modern design, the SL5000 clearly stands out from previous control housings and is convincing nevertheless due to its high flexibility and modularity. Four different profiles in combination allow a wide variety of applications and profile depths - optionally as a front or rear door version. The contour of the profiles offer a very high rigidity, whereby different dimensions in height and width can be realized, also in combination with an additional desk housing.

The front can be designed as a classic front panel as well as a full-surface glass front or as a combination with dividers. The high degree of protection, individual colouring and mechanical processing round off the SL5000.

**Technical Data**

<b>Material</b>	Aluminium
<b>Surface</b>	powder coated
<b>Colour</b>	RAL7035 / Individual colouring
<b>Dimensions</b>	Variable in width and depth
<b>Protection class</b>	IP 54 acc. to EN 60529
<b>Gasket</b>	CR-round cord
<b>Temperature application area</b>	-30 °C to +80 °C

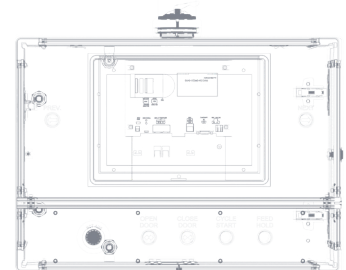
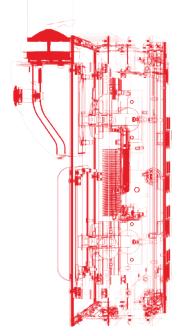

- + Individual colouring possible
- + Integration of buttons
- + 4 different profiles
- + Individual processing of the sides / front and back wall
- + Long-term availability
- + High degree of protection
- + High flexibility
- + Integration into existing suspension systems

**Installation depths**

Single profile	Installation depth
Profile 4X	39,8 mm
Profile 6X	54,5 mm
Profile 9X	87,5 mm
Profile 13X	131,5 mm

**Connection options**

Profile	Connection side	Carrier
Profile 4X	Backwall	FPA
Profile 6X	Backwall	FPA
Profile 9X	Side A/B and backwall	GT 48/2; GTS; FPA
Profile 13X	Side A/B and backwall	GT 48/2; GTS; GTN II; FPA

The connection to our device carrier systems / third-party systems depends on the selected profiles of the SL5000. For example, the smallest profile depths (profile 4X and 6X) can only be connected via the rear wall, since the couplings of the device carrier systems do not offer enough space on side A/B. Individual processing for third-party systems/VESA is possible but must be checked!

**Combinations**

Profilecombination	Installation depth	Carrier connection	Door
4X + 4X	72,4 mm	Backwall	front
4X + 6X	87,1 mm	Backwall	front
4X + 9X	120,1 mm	9X	front
4X + 13X	164,1 mm	13X	front
6X + 4X	87,1 mm	Backwall	front
6X + 6X	101,8 mm	Backwall	front
6X + 9X	134,8 mm	9X	front
6X + 13X	178,8 mm	13X	front
9X + 4X	120,1 mm	9X	back
9X + 6X	134,8 mm	9X	back
9X + 9X	167,8 mm	9X	front/back
9X + 13X	211,8 mm	13X	front
13X + 4X	164,1 mm	13X	back
13X + 6X	178,8 mm	13X	back
13X + 9X	211,8 mm	13X	back
13X + 13X	255,8 mm	13X	none

**+ Front panel / Back**

The front panel and the rear panel are made of aluminium with a thickness of 3 mm.

The following options are available for front panel attachment:

- + Glued front panel
- + Screwed front panel

The rear panel can be screwed or hinged.

In the case of hinged profile combinations, a screwed rear wall must be used for reasons of stability to get voted!

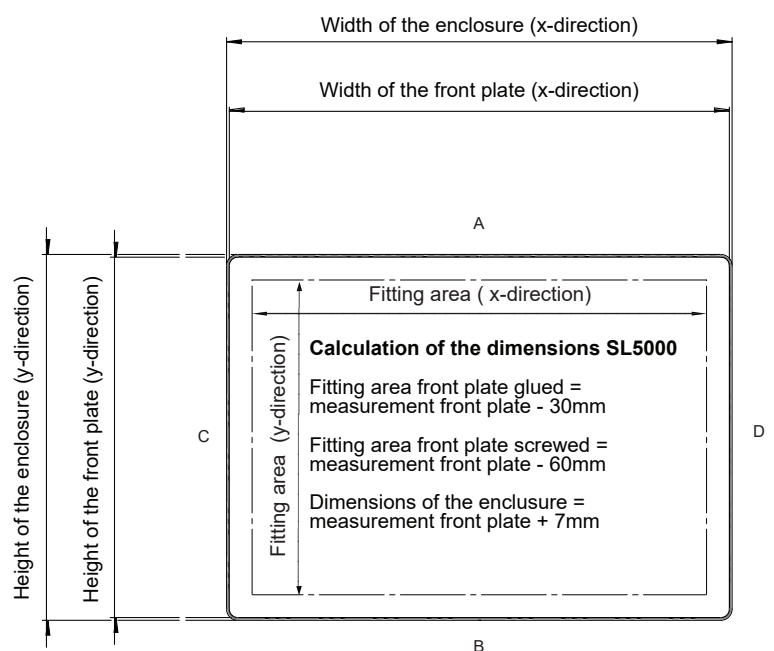



## + Highlights

Enjoy a variable control enclosure with a variety of assembly possibilities:

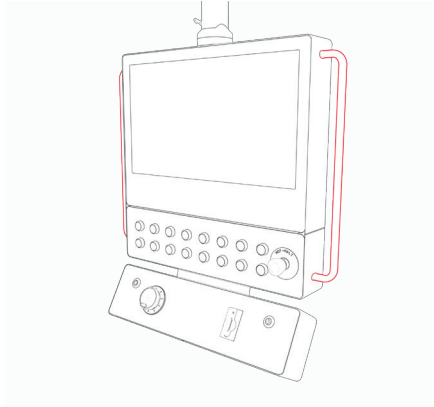

Optional accessories, i.e. external handles or indicator lights

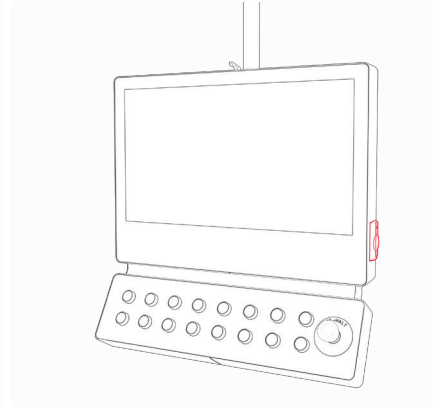

Lateral integration of fixtures, i.e. EKS system

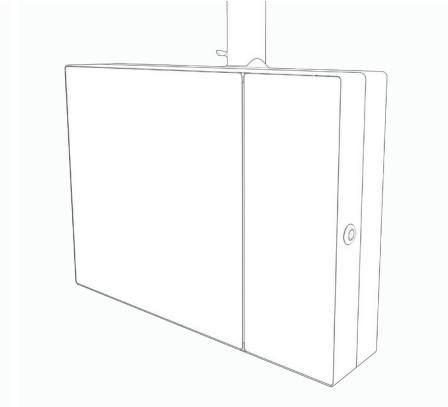

Individual dimensions and designs

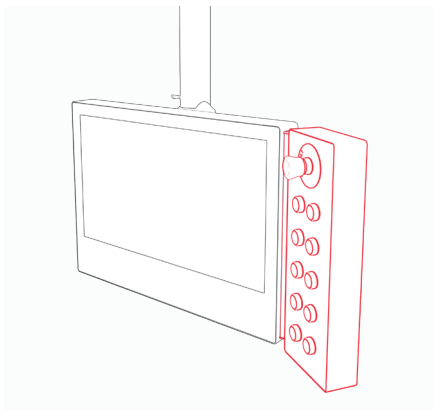

Desk connection, there are many deskversions available

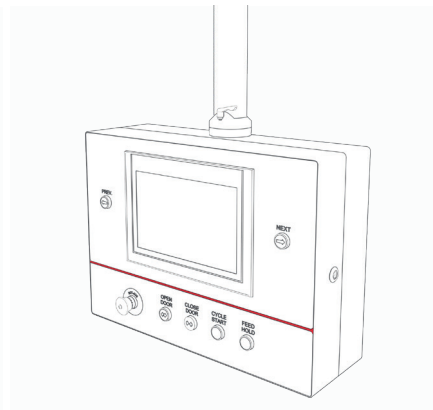

Horizontal divider

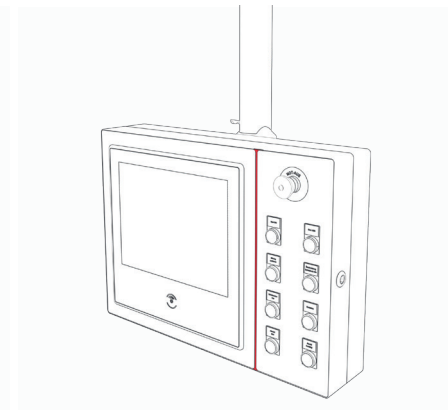

Vertical divider

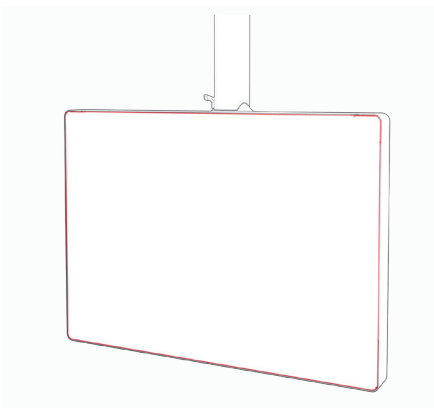

Glued front panel without visible fastening screws

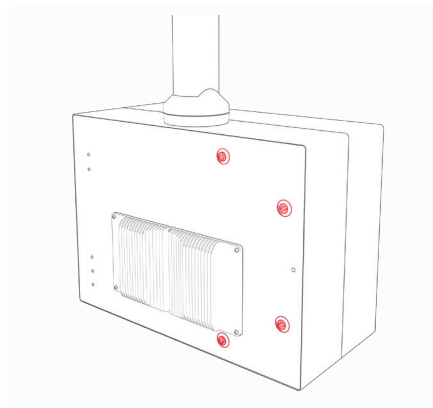

Hinged back wall

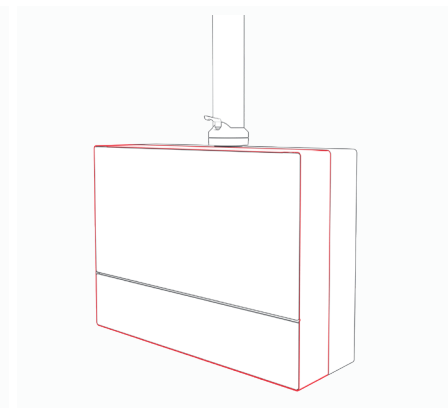

Profile combinations to increase the installation depth or as a front door

## + Connection Options

The SL 5000 system housings can be connected to the entire ROSE support arm portfolio in a variety of ways. In addition to the practical flat panel adapter, numerous rotatable, tiltable and height-adjustable adapters are available that can be combined with the support profiles to form a support arm that perfectly matches your application.

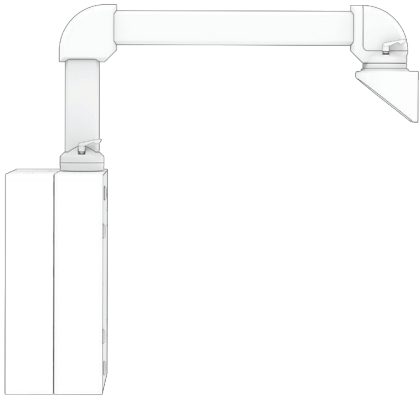

Support arm - hanging

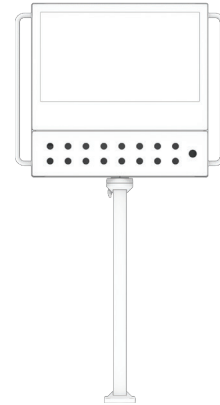

Standing pillar model

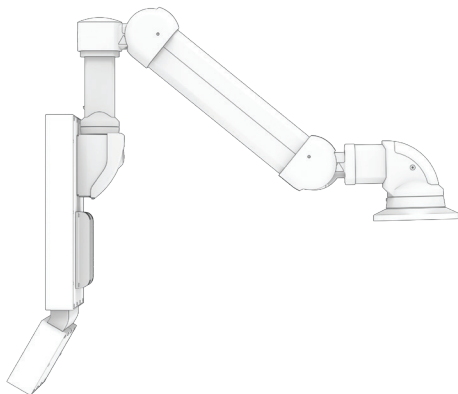

Height-adjustable support arm  
(light to medium loads)  
Ergonomic connection via GTV Light

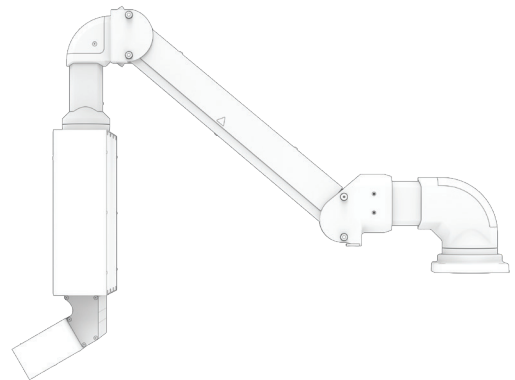

Height-adjustable support arm  
(heavy loads)  
Ergonomic connection via GTV 2.0

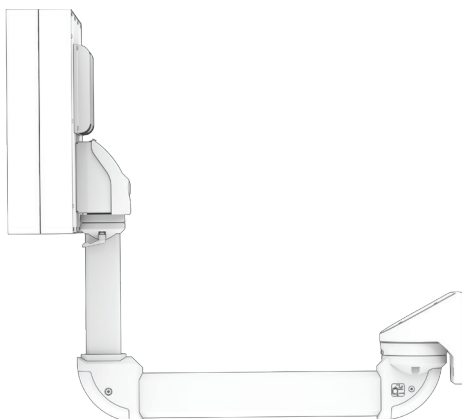

Support arm - standing

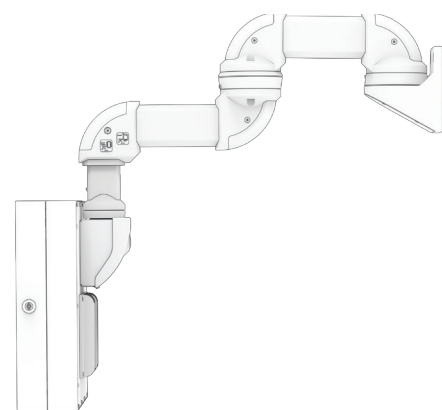

Support arm - hanging  
with intermediate joint

## + Application Examples

Regardless of the requirements you previously had on a control housing - with the new SL 5000, implementation is a lot easier and the result is significantly more individual. In addition to the practical divider, which can be arranged both vertically and horizontally, there are options such as front glass installation, desk attachments on each side of the housing and individual colour design for all housing components. In addition, your finished solution will benefit from the simple, timeless elegant design without classic corner pieces.



- Depth of the housing ca. 95 mm
- Full-surface glass front above with separator and aluminium front plate with integrated push-button
- Hinged back wall
- External handles on side C/D
- Console housing with integration of the EKS-system and rotary encoder
- Connection of the GTS support arm system to side A



- Depth of the housing ca. 140 mm
- Full-surface glass front above with backlit company logo / status display
- Aluminium front panel with built-in control and integration of buttons
- Hinged back wall
- Connection of the GTN II support arm system to A and B



- Depth of the housing ca. 60 mm
- Full-surface glass front
- Desk housing for button integration
- Screwed back wall
- Side integration of the EKS-system
- Connection of the flat panel adapter to the rear wall



- Depth of the housing ca. 95 mm
- Full-surface glass front
- Desk housing on the side for button integration
- Screwed back wall
- Side integration of the EKS-system
- Connection of the flat panel adapter to the rear wall





- + Modern enclosure system for control and display systems
- + Flexible size variability in height and width with 6 enclosure profiles
- + Easy mounting of door hinge
- + Integrated handle system

#### Included in delivery

Complete enclosure system incl. corners, seals, fixing elements, rear panel or door, front panel fixing set.

### Technical data

<b>Material</b>	Profile: DIN EN 573 EN AW-AMgSi Cast corner: DIN EN AC-ALSi 12 Cu 1 (Fe)
<b>Painting</b>	Powder coating or natural anodized
<b>Colour</b>	Profile: optional RAL 7035 or natural anodized, Corner element: optional RAL 7035, light grey or RAL 9007, grey aluminium special colour on request
<b>Ingress protection</b>	IP 65 to EN 60529
<b>Temperature range</b>	-30 °C to +80 °C

**Profile connecting Executions**

fixed

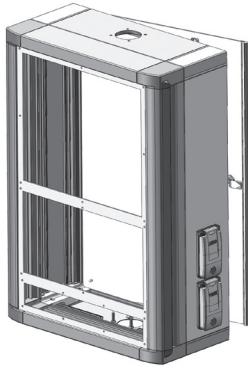

hinged

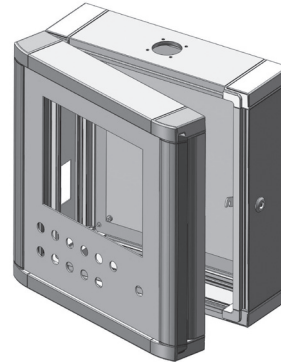
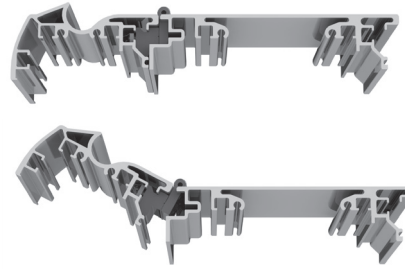

**Possible combinations**

Profile single	Combinations with hinge	Combinations fixed
Profile 1 (Mounting depth = 80 mm)	P 1 + 4 (Mounting depth = 220 mm) door front	P 1 + 4 (Mounting depth = 220 mm)
Profile 2 (Mounting depth = 130 mm)	P 2 + 4 (Mounting depth = 270 mm) door front	P 2 + 4 (Mounting depth = 270 mm)
Profile 3 (Mounting depth = 190 mm)	P 5 + 6 (Mounting depth = 135 mm) door front	P 5 + 6 (Mounting depth = 135 mm)
Profile 5 (Mounting depth = 55 mm)	P 1 + 6 (Mounting depth = 160 mm) door front	P 1 + 6 (Mounting depth = 160 mm)
	P 2 + 6 (Mounting depth = 210 mm) door rear	P 2 + 6 (Mounting depth = 210 mm)
	P 5 + 4 (Mounting depth = 195 mm) door front	P 5 + 4 (Mounting depth = 195 mm)
	P 3 + 6 (Mounting depth = 270 mm) door rear – on request	P 3 + 6 (Mounting depth = 270 mm)

**Front plate fitting**

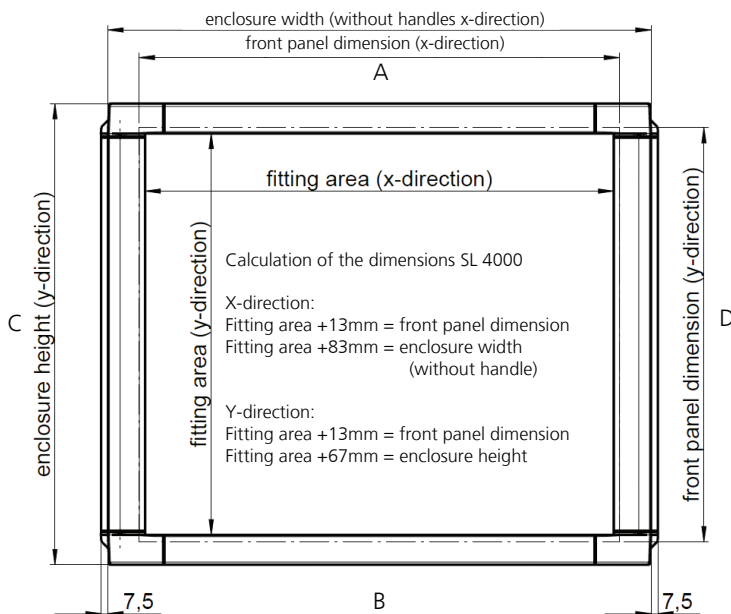

**Front plate mounting**

Front panel is mounted from inside. Quick and easy installation with four clamping bars.

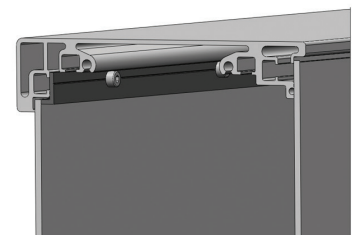

**Product range**

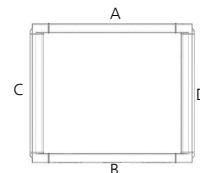

**Overview profile depth**

Basic profile

**Profile 5 Handle profile Side C/D**

External dimensions 65/70 mm  
Mounting depth 55 mm

**Profile 5 Body profile Side A/B**

External dimensions 65/70 mm  
Mounting depth 55 mm

**Profile 1 Handle profile 90 Side C/D**

External dimensions 90/95 mm  
Mounting depth 80 mm

**Profile 1 Body profile 90 Side A/B**

External dimensions 90/95 mm  
Mounting depth 80 mm

**Profile 2 Handle profile 140 Side C/D**

External dimensions 140/145 mm  
Mounting depth 130 mm

**Profile 2 Body profile 140 Side A/B**

External dimensions 140/145 mm  
Mounting depth 130 mm

## Basic profile

### Profile 3 Handle profile 200 Side C/D

External dimensions 200/205 mm  
Mounting depth 190 mm

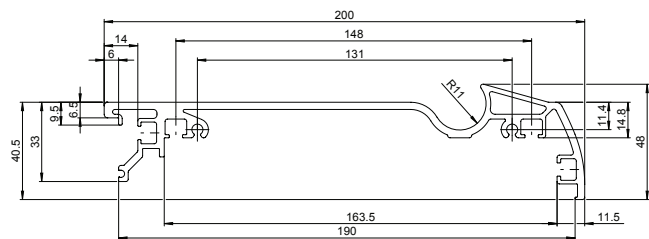

### Profile 3 Body profile 200 Side A/B

External dimensions 200/205 mm  
Mounting depth 190 mm

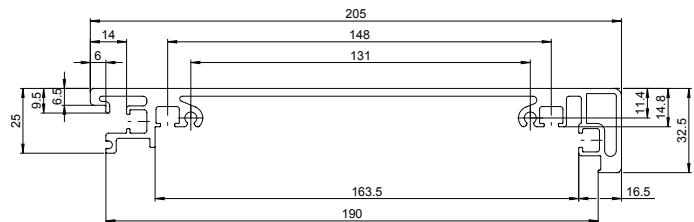

## Combination profile

### Profile 6 Side C/D

External dimensions 85,5 mm  
Mounting depth 80 mm

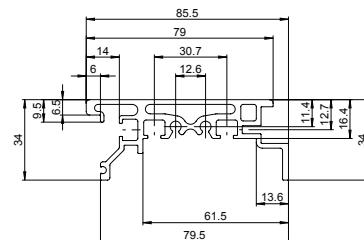

### Profile 6 Side A/B

External dimensions 85,5 mm  
Mounting depth 80 mm

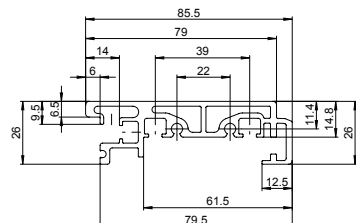

### Profile 4 Side C/D

External dimensions 153 mm  
Mounting depth 140 mm

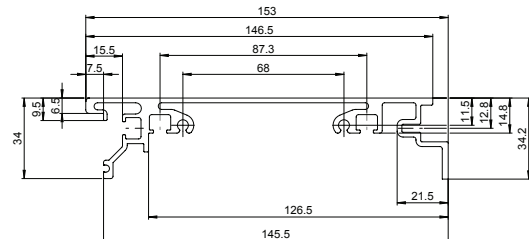

### Profile 4 Side A/B

External dimensions 153 mm  
Mounting depth 140 mm

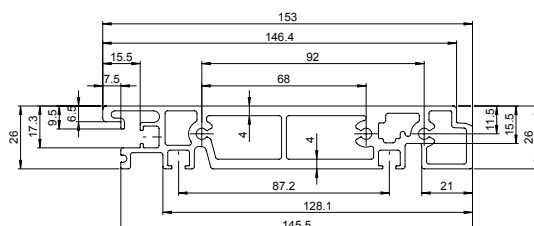

Overview profile combinations

**Profile 1 and 4 Side C/D**

Mounting depth 220 mm



**Profile 1 and 4 Side A/B**

Mounting depth 220 mm



**Profile 2 and 4 Side C/D**

Mounting depth 270 mm



**Profile 2 and 4 Side A/B**

Mounting depth 270 mm



**Profile 5 and 6 Side C/D**

Mounting depth 135 mm

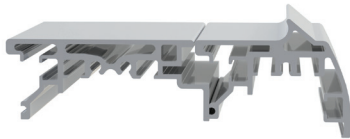

**Profile 5 and 6 Side A/B**

Mounting depth 135 mm



**Profile 1 and 6 Side C/D**

Mounting depth 160 mm



**Profile 1 and 6 Side A/B**

Mounting depth 160 mm



**Profile 2 and 6 Side C/D**

Mounting depth 210 mm



**Profile 2 and 6 Side A/B**

Mounting depth 210 mm



**Profile 5 and 4 Side C/D**

Mounting depth 195 mm



**Profile 5 and 4 Side A/B**

Mounting depth 195 mm



## Connection to suspension system

	GTS GTKe	GT 48/2	GTN II	GT 50/2	GT 60/2	GT 80/2	GTK 80	GTL	Moterm
Operating enclosure									
Profile 1	•	•							•
Profile 2	•	•	•	•	•				•
Profile 3			•	•	•	•	•	•	•
Profile 1+4			• Profile 4	• Profile 4	• Profile 4	• Profile 4		• Profile 4	•
Profile 2+4			• Profile 4	• Profile 4	• Profile 4	• Profile 4		• Profile 4	•
Profile 5+6	• Profile 6 only GTS								•
Profile 5	only possible via rear wall								
Profile 1+6	• Profile 6 only GTS								•
Profile 2+6			• Profile 2	• Profile 2	• Profile 2				•
Profile 5+4			• Profile 4	• Profile 4	• Profile 4	• Profile 4		• Profile 4	•



SL 4000 with hinged rear wall

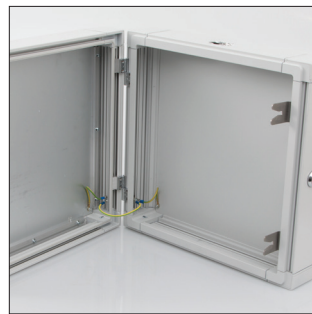

Hinged profile combination with fixed rear wall



Integrated handle profile



SL 4000 with additional fittings



## Accessories

### Fixing set



Order No.	Execution
<b>10.03 60 04</b>	M4, set = 8 pcs
<b>10.03 60 01</b>	M5, set = 8 pcs

### Handle



set = 2 pcs

Order No.	Handle length	Front plate width/height (mm)
<b>20.60 40 02</b>	250	265-314
<b>20.60 40 03</b>	300	315-364
<b>20.60 40 04</b>	350	365-414
<b>20.60 40 05</b>	400	415-464
<b>20.60 40 06</b>	450	465-514
<b>20.60 40 07</b>	500	515-614
<b>20.60 40 09</b>	600	615-664
<b>20.60 40 10</b>	650	665-714
<b>20.60 40 11</b>	700	715-764
<b>20.60 40 12</b>	750	765-814
<b>20.60 40 13</b>	800	815

### Hinge set



Order No.	Execution
<b>20.10 90 50</b>	for profile 1 and 2
<b>20.10 90 60</b>	for profile 3

### Wall holder



Order No.	Execution
<b>20.10 90 30</b>	for SL 4000 profile 2 and 3

### Wall mounting set

Order No.	Execution
<b>45.80 10 99</b>	Locking plate GTN II with „Lütze“ cable entry and 4 spacers for wall mounting

### Aerator set



Order No.	Execution
<b>45.80 10 02</b>	Aerator consisting of 3 aerators for fixing in SL 4000

Further accessories see Commander system accessories

Company \_\_\_\_\_ Telephone \_\_\_\_\_  
 Contact \_\_\_\_\_ Telefax \_\_\_\_\_  
 Address \_\_\_\_\_ E-Mail \_\_\_\_\_  
 Project \_\_\_\_\_ Quantity \_\_\_\_\_ Lot size \_\_\_\_\_

**Operating enclosure**

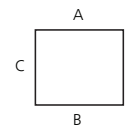

Profiles

- Profile 1 (Mounting depth = 80 mm)   
 Profile 2 (Mounting depth = 130 mm)   
 Profile 3 (Mounting depth = 190 mm)   
 Profile 5 (Mounting depth = 55 mm)

**Profile combination**

- Profile 1 + 4 (Mounting depth = 220 mm)   
 Profile 2 + 4 (Mounting depth = 270 mm)   
 Profile 5 + 6 (Mounting depth = 135 mm)  
 Profile 1 + 6 (Mounting depth = 160 mm)   
 Profile 2 + 6 (Mounting depth = 210 mm)   
 Profile 5 + 4 (Mounting depth = 195 mm)

Connection  fixed  hinged side (C or D) \_\_\_\_\_ (rear wall screwed)  
 Lock types  Square (7 mm)     Triangular (7 mm)     Double ward (3 mm)  
 Square (8 mm)     Triangular (8 mm)     Special lock type \_\_\_\_\_

**Front plate**

- without front plate  
 Panel direct mounting by mounting frame / control type \_\_\_\_\_  
 with front plate required connector surface W x H (mm) \_\_\_\_\_ x \_\_\_\_\_  
 required front panel dimension W x H (mm) \_\_\_\_\_ x \_\_\_\_\_

**Colour**

- Standard  Profile RAL 7035, corner pieces RAL 7035  
 Profile natural anodized, corner pieces RAL 9007  
 Special colour RAL (please specify RAL colour for each)     Profile RAL \_\_\_\_\_ Corner RAL \_\_\_\_\_  
 Profile anodized    Corner cap RAL \_\_\_\_\_

**Door / Rear wall**

- Rear wall screwed (always with hinged profile combination)  
 Door  left hinged (side C)     right hinged (side D)  
 Lock types turn bolt fastener - small    turn bolt fastener - large  
 Square (6 mm)     Square (8 mm)     Triangular (7 mm)  
 Triangular (6.5 mm)     Square (7 mm)     Triangular (8 mm)  
 Slot (1.5 mm)     Double ward (3 mm)  
 Special lock type \_\_\_\_\_ (note: reduction of IP rating)  
 Further information of machining \_\_\_\_\_  
 Modified acc. drawing no. \_\_\_\_\_ (please enclose)

**Modifications**

- Modified acc. drawing no. \_\_\_\_\_ (please enclose)

**Front plate**

- Cutting W x H (mm) \_\_\_\_\_ x \_\_\_\_\_  
 and/or manufacturer/type of controller \_\_\_\_\_  
 Drill holes diameter (mm) \_\_\_\_\_ number \_\_\_\_\_  
 Other front plate modifications / special Executions \_\_\_\_\_

**Profile**

- Modified acc. drawing no. \_\_\_\_\_ (please enclose)  
 Cutting W x H (mm) \_\_\_\_\_ x \_\_\_\_\_  
 Drill holes diameter (mm) \_\_\_\_\_ number \_\_\_\_\_  
 Other information for profile processing (items, etc.) \_\_\_\_\_



**Connection - Suspension system**

- Side A (top)     Side B (bottom)     Rear wall (on request)  
 GTKe     GT 48/2     GTS     GTN II     GT 50/2     GT 60/2     GT 80/2  
 GTK 80     Moterm     External system (please name drawing and manufacturer)

	GTKe	GT 48/2	GTS	GTN II	GT 50/2	GT 60/2	GT 80/2	GTK 80	GTL	Moterm
Profile 1	x	x	x							x
Profile 2	x	x	x	x	x	x				x
Profile 3				x	x	x	x	x	x	x
Profile 5	only possible via rear wall									
Profile 1+4				x	x	x	x		x	x
Profile 1+6	x	x	x							x
Profile 2+4				x	x	x	x		x	x
Profile 2+6				x	x	x				x
Profile 5+4				x	x	x	x		x	x
Profile 5+6			x							x

**Further notes**

**Accessories**

**Handles (additionally)**

Number \_\_\_\_\_ Side(s) \_\_\_\_\_

- Standard (Order No.): \_\_\_\_\_  
 Special length (mm) \_\_\_\_\_



**Hinge set (only single profile)**

Hinge side     Side C (left)     Side D (right)

Any further information of the position \_\_\_\_\_



**Wall holder set (only single profile)**

Position (side)     Side C (left)     Side D (right)

Any further information of the position \_\_\_\_\_



**Document holder**

Position (side)     C (left)     D (right)

Any further information of the position \_\_\_\_\_



**Fixing set**

- Spring nut set M4 (8 pieces)    number \_\_\_\_\_  
 Spring nut set M5 (8 pieces)    number \_\_\_\_\_



**Single interfaces (IP 65)**

- USB      RJ45 

Any further information to front panel interfaces (requirements, position etc.) \_\_\_\_\_

**Multiple interfaces**

Interfaces and power supplies for optional mounting on the front plate, rear wall or side of the profile 2, 3 and 4.

**Single flap** (possible at front panel, rear wall or lateral on profile 2, 3 and 4)

**Metal**

- Type 1                       Type 2                       Type 3

Plastic with knob

- Type 4                       Type 5                       Type 6

Plastic with double ward lock

- Type 7                       Type 8                       Type 9

**Double flap** (possible only at front panel and rear wall)

**Metal**

- Type 11                       Type 12                       Type 13

Plastic with knob

- Type 14                       Type 15                       Type 16

Plastic with double ward lock

- Type 17                       Type 18                       Type 19

**Protective contact sockets (screw terminals)**

- |   |  |
|---|--|
| <input type="checkbox"/> USA (NEMA 5-15)  | <input type="checkbox"/> Australia         |
| <input type="checkbox"/> China (C C C)  | <input type="checkbox"/> Denmark           |
| <input type="checkbox"/> Germany (VDE)  | <input type="checkbox"/> England (BS)      |
| <input type="checkbox"/> Germany (VDE) orange   | <input type="checkbox"/> France (UTE)      |
| <input type="checkbox"/> Germany (VDE) yellow   | <input type="checkbox"/> Italy (CEI 23-16) |
| <input type="checkbox"/> Switzerland  | <input type="checkbox"/> India (IS 1293)   |
| <input type="checkbox"/> Germany (VDE) with cutout for circuit breaker (only with double flap, plastic) |  |
| <input type="checkbox"/> Other _____  |  |



**Data interfaces**

- |  |              |
|--|--------------|
| <input type="checkbox"/> SUB-D9 (socket)                           | number _____ |
| <input type="checkbox"/> SUB-D9 (plug)                             | number _____ |
| <input type="checkbox"/> UB-D15 (socket)                           | number _____ |
| <input type="checkbox"/> RJ12, 6-pol. plastic                      | number _____ |
| <input type="checkbox"/> RJ45, 8-pol. Metal, CAT5e (socket/socket) | number _____ |
| <input type="checkbox"/> USB (socket/socket)                       | number _____ |
| <input type="checkbox"/> Other _____                               | number _____ |

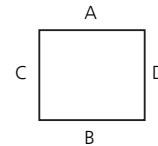

Combination (Specification see below)

**Position**

- Front plate                       Rear wall (door)                       Side profile (profile 2 / 3)

Any further information to front panel interfaces (requirements, position etc.) \_\_\_\_\_

**Further accessories** \_\_\_\_\_

**Console attachment****Profile type** Profile 1  
(Mounting depth = 80 mm) Profile 2  
(Mounting depth = 130 mm)**Front plate** without front plate Panel direct mounting by frame / control type \_\_\_\_\_ with front plate required connector surface W x H (mm) \_\_\_\_\_ x \_\_\_\_\_

required front panel dimension W x H (mm) \_\_\_\_\_ x \_\_\_\_\_

**Colour****Standard** Profile RAL 7035, corner pieces RAL 7035 Profile natural anodized, corner pieces RAL 9007 Special colours (please specify RAL colour for each) Profile RAL \_\_\_\_\_ corner RAL \_\_\_\_\_ Profile anodized corner RAL \_\_\_\_\_**Door / Rear wall****Standard** screwed other (on request) \_\_\_\_\_**Modification****Front plate** Modified acc. drawing no. \_\_\_\_\_ (please enclose) Cutting W x H (mm) \_\_\_\_\_ x \_\_\_\_\_ and/or manufacturer/type of controller \_\_\_\_\_ Drill holes diameter (mm) \_\_\_\_\_ number \_\_\_\_\_

Other front plate modifications (Positionen usw.) \_\_\_\_\_

**Profile** Modified acc. drawing no. \_\_\_\_\_ (please enclose) Cutting W x H (mm) \_\_\_\_\_ x \_\_\_\_\_ Drill holes diameter (mm) \_\_\_\_\_ number \_\_\_\_\_

Other profile modifications (Positionen usw.) \_\_\_\_\_



- + Universal control enclosure for automation technology
- + Variable size in height, width and depth
- + Hinged door profile at front and rear
- + Front plate insertion from front or rear

**Included in delivery**

Enclosure body with rear wall, fixing elements, cover profile with corners

**Technical data**

<b>Material</b>	Profile: DIN EN 573 EN AW-ALMgSi Cast corner: DIN EN 1706 EN AC-AISI 12 Cu 1 (Fe)
<b>Painting</b>	Powder coating
<b>Colour</b>	optional RAL 7035, light grey or natural anodized special colour on request
<b>Ingress protection</b>	IP 65 to EN 60529
<b>Temperature range</b>	-30 °C to +80 °C





**Product range**

**I. Profile for installation with front plate**

**Profile 1 Hinged frame profile**



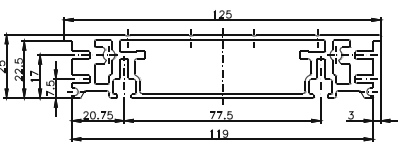

**Profile 2 Intermediate frans**

**Profile 3 Body profile 170**

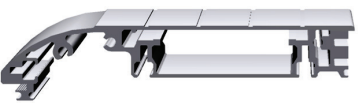
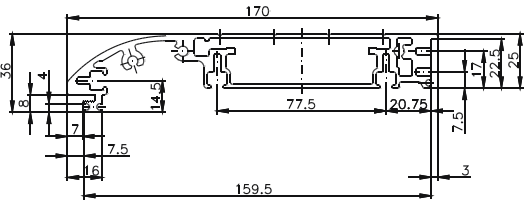

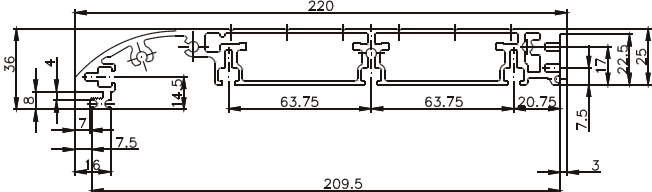

**Profile 4 Body profile 220**



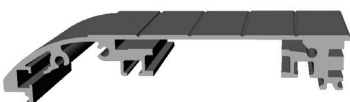
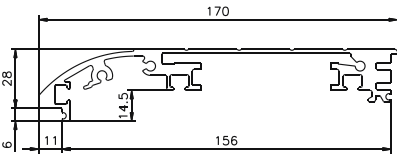

**II. Profile for direct mounting of installation**

**Profile 3 Direct mounting**

**Profile 4 Direct mounting**

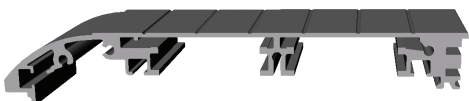
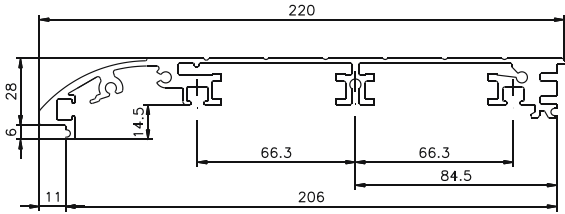
## Example of profile combination options

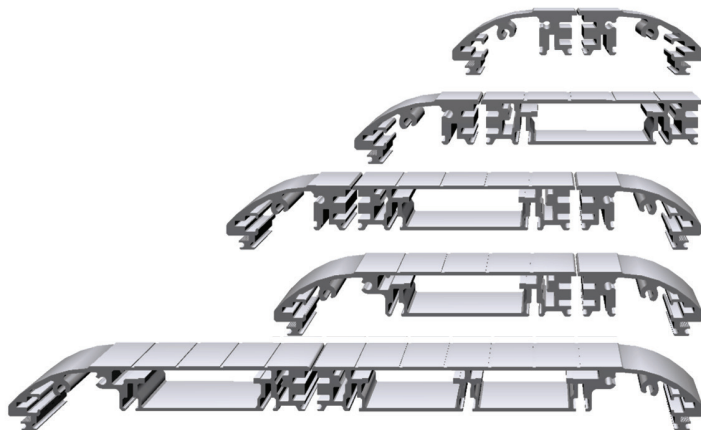

Mounting depth 125 mm

Mounting depth 184 mm

Mounting depth 250 mm

Mounting depth 225 mm

Mounting depth 375 mm

Other profile combinations on request

## Profile connection options

### Fixed

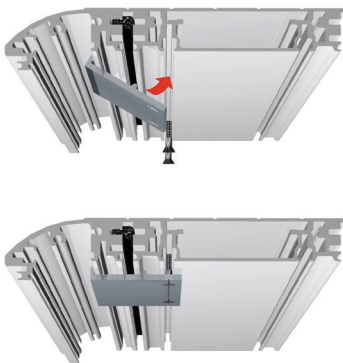

### Hinged

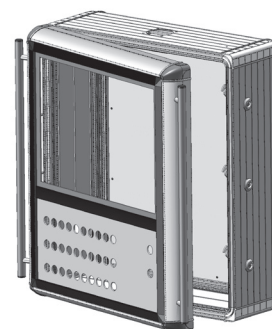
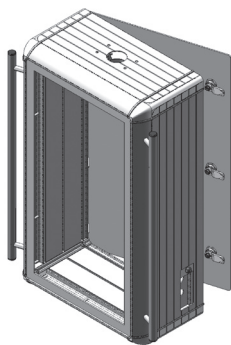
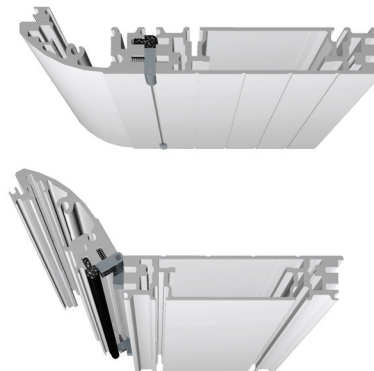

### Profile info:

- All profiles can be combined with one another
- Profiles can be attached with fixed or hinged connections.
- If straight profile side (see example 2) the rear panel can also be designed as a door.
- The max. mounting depth in the case of operational enclosures is 675 mm (Profile 4 + 2 + 2 + 4)
- The max. mounting depth with console attached is 425 mm (Profile 4 + 4)
- The max. enclosure size is limited by the front plate to 1000 x 1000 mm



**Connection to suspension system**

Profile	GTK electronic	GTS	GT 48/2	GTN II	GT 50/2	GT 60/2	GT 80/2	GTK 80	GTL
1	•	•	•	•	•	•			
1 + 1 (fixed or hinged)	•	•	•	•	•	•			
1 + 2 (hinged)	•	•	•	•	•	•			
1 + 2 (fixed)	•	•	•	•	•	•	•	•*	
1 + 2 (hinged) + 1 (hinged)	•	•	•	•	•	•	•		
1 + 2 (hinged + 1 (fixed)	•	•	•	•	•	•	•	•*	
1 + 2 (fixed) + 1 (fixed)	•	•	•	•	•	•	•	•	
2	•	•	•	•	•	•	•		
3	•	•	•	•	•	•	•		•
3 + 1 (hinged)				•	•	•	•		•
3 + 1 (fixed)				•	•	•	•	•**	•
3 + 2 (hinged) + 1 (hinged)				•	•	•	•		•
3 + 2 (fixed) + 1 (hinged)				•	•	•	•	•	•
4				•	•	•	•	•	•

\* 10 mm projection downstream of at rear  
 \*\* every 5 mm projection to front and at rear

**Front plate fitting**

Execution I  
 Front plate without cover profile or rubber cover

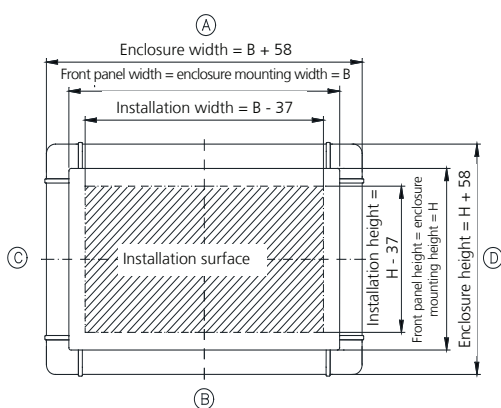

Execution II  
 Front plate with cover profile or rubber cover surrounding

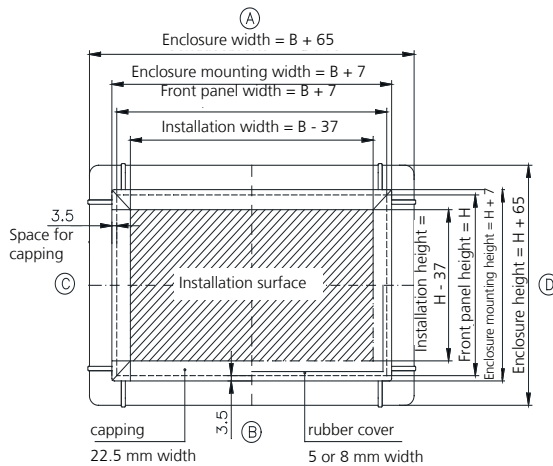

**Front plate fastening**

- Zinc diecast latch with slot for insertion of M4 or M5 rack connecting nuts screwed Execution
- Turn the catch round to enable the front plate to be screwed in directly from the back



- Flush closure with profile

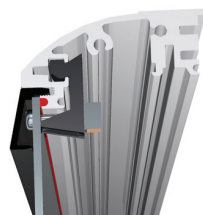

- With M4 or M5 rack connecting nut
- Concealed capping screw heads

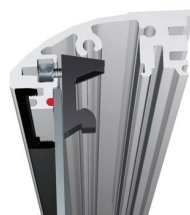

- Latch reversed screwed into profile

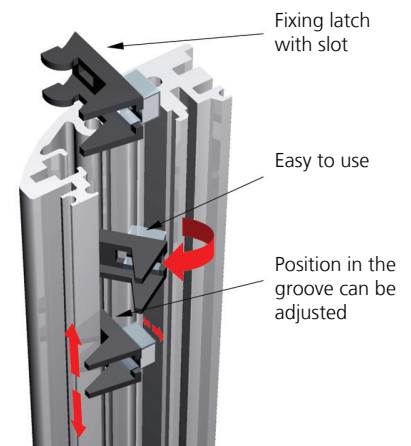

## Accessories

### Fastening set



Order No.	Execution
<b>20.60 10 01</b>	M4
<b>20.60 10 02</b>	M5
<b>20.60 10 03</b>	Set for front plates

### FCP - Foil Control Panel



Order No.	Execution
<b>20.60 10 50</b>	FCP 240/3
<b>20.60 10 51</b>	FCP 335/6
<b>20.60 10 52</b>	FCP 483/8

### Handle



set = 2 pcs

Order No.	Handle length (mm)	Front plate width/height (mm)
<b>20.60 40 02</b>	250	265-314
<b>20.60 40 03</b>	300	315-364
<b>20.60 40 04</b>	350	365-414
<b>20.60 40 05</b>	400	415-464
<b>20.60 40 06</b>	450	465-514
<b>20.60 40 07</b>	500	515-614
<b>20.60 40 09</b>	600	615-664
<b>20.60 40 10</b>	650	665-714
<b>20.60 40 11</b>	700	715-764
<b>20.60 40 12</b>	750	765-814
<b>20.60 40 13</b>	800	815

### Coupling flange



Order No.	Execution
<b>20.60 10 07</b>	GT 48/2 and GTK electronic

### Mounting bracket set

Order No.
<b>10.03 31 01</b>

### Installation rail set



Order No.	Execution
<b>54.00 00 16</b>	Rail length 80 mm
<b>54.00 00 24</b>	Rail length 160 mm
<b>54.00 00 32</b>	Rail length 240 mm



## Accessories

### Adapter plate P1/P2 onto GT 80/2

Order No.

20.60 10 08

### Locking plate

For closing of unneeded coupling holes

Order No.

Execution

20.60 30 01	powdered GT 48/2 and GTK electronic
20.60 30 02	powdered GT 50/2 and GT 60/2
20.60 30 03	powdered GT 80/2
20.60 30 04	powdered GTK 80
20.60 30 05	powdered GTN II
20.60 30 11	anodized GT 48/2 and GTK electronic
20.60 30 12	anodized GT 50/2 and GT 60/2
20.60 30 13	anodized GT 80/2
20.60 30 14	anodized GTK 80
20.60 30 15	anodized GTN II

### Control attachment set



30° or 50° inclination possible depending on assembly. Standard length 300 mm, larger or smaller lengths on request.

### Insert bay



Available for Profiles 2, 3 and 4. The ingress protection is determined by the fitted equipment. It is possible to modify the interior enclosure panel walls individually. The size of the enclosure gives the maximum connector area. In the case of profile combinations it is provided on the hinge side!

### Linking bar



For installation of two or more front plates within one enclosure

Further accessories see Commander system accessories

Company \_\_\_\_\_ Telephone \_\_\_\_\_

Contact \_\_\_\_\_ Telefax \_\_\_\_\_

Address \_\_\_\_\_ E-Mail \_\_\_\_\_

Project \_\_\_\_\_ Quantity \_\_\_\_\_ Lot size \_\_\_\_\_

**Dimensions Operating enclosures**

For console versions, please also fill out the following page - „Console attachment enclosures“.

**Mounting depth**

T (mm) \_\_\_\_\_ of combination of profiles (please always specify from front to rear):

Profile no. \_\_\_\_\_ + Profile no. \_\_\_\_\_ + Profile no. . \_\_\_\_\_ + Profile no. \_\_\_\_\_

Connection:  fixed  hinged side \_\_\_\_\_  fixed  hinged side \_\_\_\_\_  fixed  hinged side \_\_\_\_\_

**Dimensions**

Please specify front panel dimensions W x H (mm) \_\_\_\_\_ x \_\_\_\_\_

and/or manufacturer/type \_\_\_\_\_

Version I  
Front panel without cover profile or rubber profile

Version II  
Front panel surrounding with cover profile or rubber profile

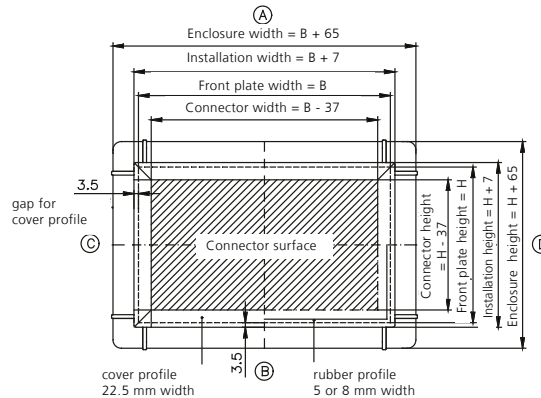
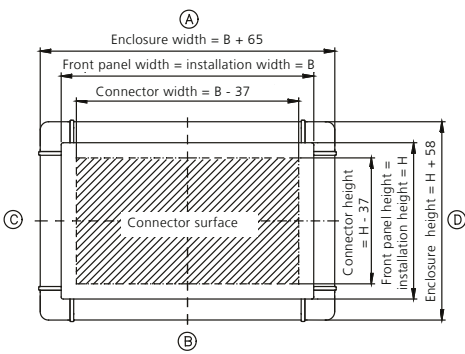

**Front panel**

- without front panel (direct mounting)  with M4 fixing set or  with M5 fixing set
- Front panel with stud bolts (flush without cover profile, dimensions, see drawing version I)
- Front panel with stud bolts (with cover profile, dimensions, see drawing version II)
- Front panel with drill holes
- Cover profile 22.5 mm (plastic black, dimensions s. version II)
- Cover profile for front panel, 5 mm rubber (Version II)
- Cover profile for front panel, 8 mm rubber (Version II)
- other front panel \_\_\_\_\_
- Finish in accordance with drawing no.: \_\_\_\_\_ (please attach)  
and/or specify manufacturer/controller type: \_\_\_\_\_
- Separation fin quantity \_\_\_\_\_ Position in accordance with drawing-no.: \_\_\_\_\_





**Accessories SL 3000 for enquiry / order**

**Company** \_\_\_\_\_

**Rear wall**

with straight closure  screwed  hinged, hinges side \_\_\_\_\_

with rounded closure  screwed, flush  with stud bolts, flush

Modified according to drawing-no. \_\_\_\_\_ (please enclose if available)

**Lock types**

Square 8 mm (Standard)

Square 7 mm  Triangular 7 mm  Triangular 8 mm

Double ward 3 mm  Other \_\_\_\_\_

**Colour**

Standard:  Profile RAL 7035, corner pieces RAL 9006, corner caps RAL 7035 powdered or

Natural anodized profile, corner pieces RAL 9006, corner caps RAL 9007 powdered

Special colours (please specify RAL colour for each):

Profile RAL \_\_\_\_\_ Corner pieces RAL \_\_\_\_\_ Corner caps RAL \_\_\_\_\_

**Suspension system**

GTK electronic, side \_\_\_\_\_  GT 48/2, side \_\_\_\_\_  GTS, side \_\_\_\_\_

GT 50/2, side \_\_\_\_\_  GT 60/2, side \_\_\_\_\_  GT 80/2, side \_\_\_\_\_

GTN II, side \_\_\_\_\_  GTK 80, side \_\_\_\_\_  GTL, side \_\_\_\_\_

Moterm  Moterm with console

Connection to console connector

Connection to profile

Other \_\_\_\_\_ Drawing-no.: \_\_\_\_\_ side \_\_\_\_\_

Total weight of fittings approx. \_\_\_\_\_ kg

for profile combination: Coupling hole on profile no. \_\_\_\_\_ or optional

specify weight distribution \_\_\_\_\_

**Handle set**

Quantity \_\_\_\_\_ side \_\_\_\_\_  Special colour RAL \_\_\_\_\_

**Other accessories**

Disc drive-/interface bay with flap (as for SL 2000), side \_\_\_\_\_

Insert slot for: \_\_\_\_\_ side \_\_\_\_\_

Finish in accordance with drawing-no.: \_\_\_\_\_

**Other modifications/ special versions**

Further modifications \_\_\_\_\_

\_\_\_\_\_

\_\_\_\_\_

in accordance with drawing-no.: \_\_\_\_\_

Drawing no.: D-SL 3000 - \_\_\_\_\_ Bl. 2

stated by Rose profile length: width \_\_\_\_\_ mm height \_\_\_\_\_ mm

**Dimensions**

**Console attachment enclosures**

**Company** \_\_\_\_\_

**Mounting depth**

T (mm) \_\_\_\_\_ of combination of profiles (please always specify from front to rear):

Profile no. \_\_\_\_\_ + Profile no. \_\_\_\_\_

Connection:  fixed  hinged, page \_\_\_\_\_

**Dimensions**

Front panel total dimensions (dimension sheet s. operational enclosure)

W x H (mm) \_\_\_\_\_ x \_\_\_\_\_  Version I  Version II

and/or manufacturer/type of controller \_\_\_\_\_

**Front panel**

without front panel (direct mounting)  with M4 fixing set or  with M5 fixing set

Front panel with stud bolts (flush without cover profile, dimensions, see drawing version I)

Front panel with stud bolts (with cover profile, dimensions, see drawing version II)

Front panel with drill holes

Cover profile 22.5 mm (plastic black, dimensions s. version II)

Cover profile for front panel, 5 mm rubber (Version II)

Cover profile for front panel, 8 mm rubber (Version II)

other front panel \_\_\_\_\_

Finish in accordance with drawing no.: \_\_\_\_\_ (please attach)

and/or specify manufacturer/controller type: \_\_\_\_\_

Separation fin quantity \_\_\_\_\_ Position in accordance with drawing-no.: \_\_\_\_\_

**Rear wall**

with straight closure  screwed  hinged, hinges side \_\_\_\_\_

with rounded closure  screwed, flush  with stud bolts, flush

Modified according to drawing-no. \_\_\_\_\_ (please enclose if available)

**Lock types**

square 8 mm (standard)  square 7 mm  double ward 3 mm

triangular 7 mm  triangular 8 mm  Other \_\_\_\_\_

**Colour**

Standard:  Profile RAL 7035, corner pieces RAL 9006, corner caps RAL 7035 powdered or

Natural anodized profile, corner pieces RAL 9006, corner caps RAL 9007 powdered

Special colours (please specify RAL colour for each):

Profile RAL \_\_\_\_\_ Corner pieces RAL \_\_\_\_\_ Corner caps RAL \_\_\_\_\_

**Console attachment set**

Standard 30°  Standard 50°

**Handle set**

Quantity \_\_\_\_\_ side \_\_\_\_\_  Special colour RAL \_\_\_\_\_

**Other accessories**

Disc drive-/interface bay with flap (as for SL 2000), page \_\_\_\_\_

Insert slot for: \_\_\_\_\_ side \_\_\_\_\_

Finish in accordance with drawing-no.: \_\_\_\_\_

**Other modifications/ special versions**

Further modifications \_\_\_\_\_

in accordance with drawing-no.: \_\_\_\_\_

Drawing no.:  
stated by Rose

D-SL 3000 - \_\_\_\_\_ Bl. 3  
profile length: width \_\_\_\_\_ mm height \_\_\_\_\_ mm



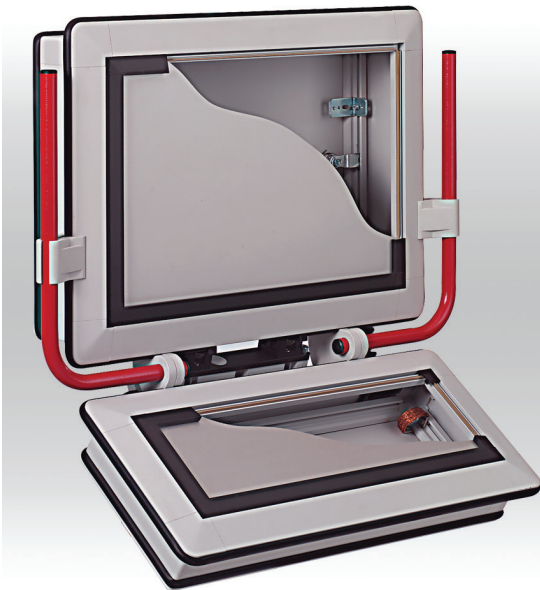

- + Enclosure system for control and display fittings
- + Variable size available in width and depth
- + All-round adaptation capabilities for accessories
- + Front panel insertion from front and rear

#### Included in delivery

Enclosure body with rear panel or door, front panel fixing set, cover profile and T-groove cover.

### Technical data

<b>Material</b>	Profile: DIN EN 573 EN AW-AMgSi Front plate, rear wall: DIN EN 573 EN AW-AMg3 Corner pieces: DIN EN 1706 EN AC-AISI 12 (Fe)
<b>Painting</b>	Powder coating
<b>Colour</b>	RAL 7035, light grey Handle tube: powdered RAL 3003, ruby red
<b>Ingress protection</b>	IP 65 to EN 60529
<b>Temperature range</b>	-30 °C to +80 °C

**Product range**

Front plate dimensions H x W (mm)	Profile 1 Mounting depth 80,5 mm	Weight (g)	Profile 2 Mounting depth 110 mm	Weight (g)	Profile 3 Mounting depth 185 mm	Weight (g)	Front plate with drill hole (insert from front)	Weight (g)	Front plate without drill hole (insert from rear)	Weight (g)
Rear wall screwed										
267 x 483	<b>19.50 65 01</b>	4700	<b>19.50 95 01</b>	5500	<b>19.50 19 01</b>	6700	<b>19.60 00 01</b>	1050	<b>19.60 00 11</b>	1030
312 x 483	<b>19.51 65 01</b>	5100	<b>19.51 95 01</b>	5900	<b>19.51 19 01</b>	7100	<b>19.60 01 01</b>	1200	<b>19.60 01 11</b>	1220
356 x 483	<b>19.52 65 01</b>	5400	<b>19.52 95 01</b>	6300	<b>19.52 19 01</b>	7500	<b>19.60 02 01</b>	1400	<b>19.60 02 11</b>	1400
155 x 483	<b>19.53 65 01</b>	4100	<b>19.53 95 01</b>	4600	-	-	<b>19.60 04 01</b>	600	<b>19.60 04 11</b>	600
Special sizes*	<b>19.59 65 01</b>		<b>19.59 95 01</b>		<b>19.59 19 01</b>		<b>19.60 03 01</b>		<b>19.60 03 11</b>	
Door at rear										
267 x 483	<b>19.50 65 00</b>	4900	<b>19.50 95 00</b>	5600	<b>19.50 19 00</b>	6600	<b>19.60 00 01</b>	1050	<b>19.60 00 11</b>	1030
312 x 483	<b>19.51 65 00</b>	5200	<b>19.51 95 00</b>	6000	<b>19.51 19 00</b>	7200	<b>19.60 01 01</b>	1200	<b>19.60 01 11</b>	1220
356 x 483	<b>19.52 65 00</b>	5500	<b>19.52 95 00</b>	6400	<b>19.52 19 00</b>	7600	<b>19.60 02 01</b>	1400	<b>19.60 02 11</b>	1400
155 x 483	<b>19.53 65 00</b>	4200	<b>19.53 95 00</b>	4700	-	-	<b>19.60 04 01</b>	600	<b>19.60 04 11</b>	600
Special sizes*	<b>19.59 65 00</b>		<b>19.59 95 00</b>		<b>19.59 19 00</b>		<b>19.60 03 01</b>		<b>19.60 03 11</b>	

\* Please specify front panel dimensions

**Technical details**

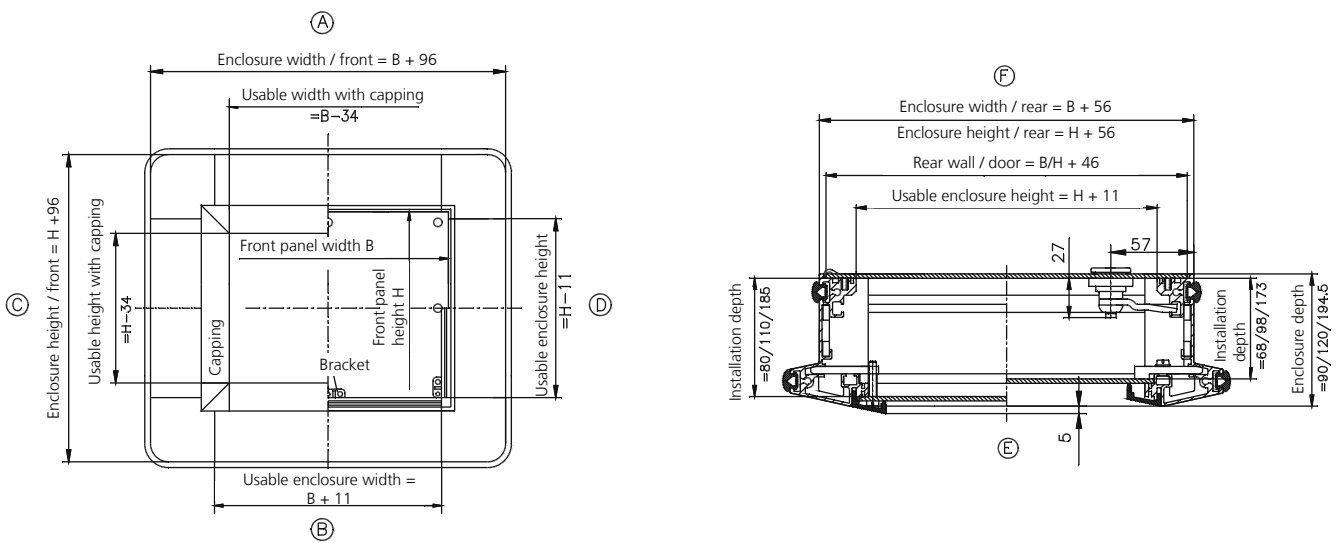

**Profile**

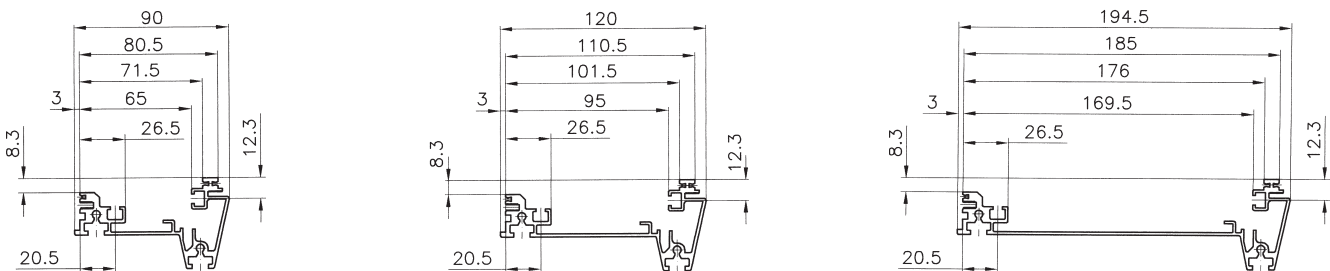

Profile 1

Profile 2

Profile 3



## Front plate fastening

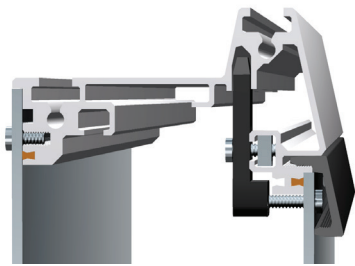

Front panel installation screwed from front

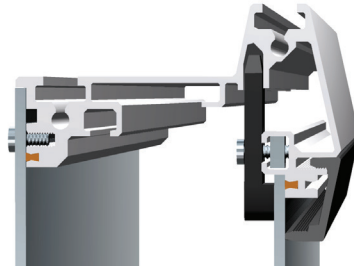

Front panel installation from rear

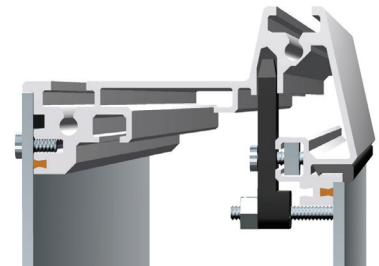

Front panel installation with stud bolts

## Accessories

### Handle set



Order No.	Execution
<b>19.60 20 01</b>	Set = 2 brackets, 1 tube, L = 256 mm
<b>19.60 20 02</b>	Handle corner set = 3 brackets, 1 tube, L = 556/395 mm
<b>19.60 20 06</b>	Set = 2 brackets, 1 tube, L = 472 mm
<b>19.60 20 04</b>	Set = 2 brackets, 1 tube, L = 301 mm
<b>19.60 20 05</b>	Set = 2 brackets, 1 tube, L = 345 mm
<b>19.60 20 99</b>	Set = 2 brackets, 1 tube, special length

### Coupling flange



Order No.	Execution
<b>19.60 20 03</b>	Profile 1 for GT 48/2 and GTK electronic (GTK electronic only 49.45 73 00 and 49.45 75 00)
<b>19.60 20 11</b>	Profile 2 for GT 48/2 and GTK electronic
<b>19.60 20 12</b>	Profile 3 for GT 48/2 and GTK electronic
<b>19.60 20 07</b>	Profile 2 for GT 50/2, GT 60/2 and GTN II
<b>19.60 20 08</b>	Profile 3 for GT 50/2, GT 60/2 and GTN II
<b>19.60 20 13</b>	Profile 3 for GT 80/2 and GTK 80
<b>19.60 20 14</b>	Profile 2 for GT 80/2
<b>19.60 20 15</b>	Profile 1 for GTS
<b>19.60 20 16</b>	Profile 2 for GTS

### Control attachment set

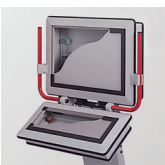

Order No.	Execution
<b>19.59 00 11</b>	15° inclination fixed
<b>19.59 00 12</b>	30° inclination fixed
<b>19.59 00 13</b>	adjustable
<b>19.59 00 98</b>	Control attachment set, 15° inclination fixed, special length*
<b>19.59 00 99</b>	Control attachment set, 30° inclination fixed, special length*

**Accessories**

**Control panel installation set**

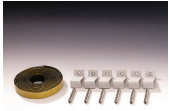

Order No.	Execution
<b>19.60 10 03</b>	for profile 3, (6 pcs)
<b>19.60 10 00</b>	for profile 1 and 2 (6 pcs)

**Hinge set**

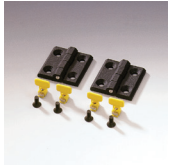

Order No.
<b>19.60 10 08</b>

**Quick fastener set**



Order No.	Execution
<b>19.60 10 07</b>	for frontplate (Set = 12 Stk)

**Linking bar**



Order No.	Execution
<b>19.59 00 20</b>	483 mm
<b>19.59 00 21</b>	Special length

**Spring nut set**

Order No.	Execution
<b>10.03 60 01</b>	M5 (8 pcs)

**Fixing set**



Order No.	Execution
<b>19.60 10 01</b>	Fixing set 1 (12 spring nuts, brackets, screws) M5
<b>19.60 10 02</b>	Fixing set 2 (30 spring nuts, brackets, screws) M5

Further accessories see Commander system accessories





Company \_\_\_\_\_ Telephone \_\_\_\_\_

Contact \_\_\_\_\_ Telefax \_\_\_\_\_

Address \_\_\_\_\_ E-Mail \_\_\_\_\_

Project \_\_\_\_\_ Quantity \_\_\_\_\_ Lot size \_\_\_\_\_

**Operation enclosures**

**Execution**

Door  rear wall screwed

**Dimensions**

Profile 1  Profile 2  Profile 3

Recessed rear panel for \_\_\_\_\_ mm mounting depth

Please specify front panel dimensions or manufacturer/controller type:



W x H (mm) \_\_\_\_\_ x \_\_\_\_\_

or manufacturer/type \_\_\_\_\_



W x H (mm) \_\_\_\_\_ x \_\_\_\_\_

or manufacturer/type \_\_\_\_\_



W x H (mm) \_\_\_\_\_ x \_\_\_\_\_

or manufacturer/type \_\_\_\_\_

**Front panel**

3 mm, with drill holes  3 mm, without drill holes  other \_\_\_\_\_ mm

Finish in accordance with drawing (please attach)

or state manufacturer/controller type: \_\_\_\_\_

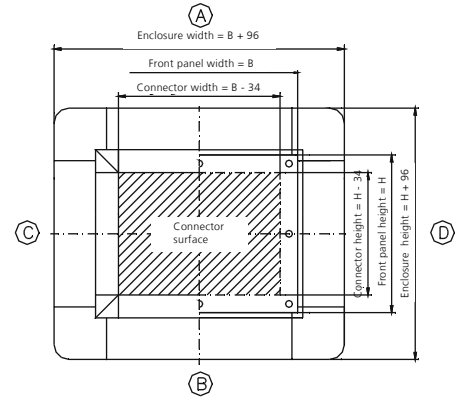

**Keyboard enclosures**

**Execution**

Door  rear wall screwed

**Dimensions**

Profile 1  Profile 2

Please specify the number and dimensions of the front panel or the manufacturer and controller type.



W x H (mm) \_\_\_\_\_ x \_\_\_\_\_ or manufacturer/type \_\_\_\_\_



W x H (mm) \_\_\_\_\_ x \_\_\_\_\_ or manufacturer/type \_\_\_\_\_

**Front panel**

3 mm, with drill holes  3 mm, without drill holes  other \_\_\_\_\_ mm

Finish in accordance with drawing (please attach)

or state manufacturer/controller type: \_\_\_\_\_

**Console attachment set**

standard \_\_\_\_\_ (Order No.)  Custom length \_\_\_\_\_ mm

**Suspension system**

- GTK electronic / GT 48/2, on side \_\_\_\_\_
- GT 50/2 / GT 60/2, on side \_\_\_\_\_
- GT 80/2 / GTK 80, on side \_\_\_\_\_
- GTN II, on side \_\_\_\_\_
- GTS, on side \_\_\_\_\_
- other \_\_\_\_\_ on side \_\_\_\_\_
- Moterm Operational enclosure from 236 mm front panel width  
Console enclosure (fixed inclination) from 440 mm front panel width  
Console enclosure (fixed inclination) from 580 mm front panel width

**Handle set**

Standard \_\_\_\_\_ (Order No.) Mounting side \_\_\_\_\_

Special length \_\_\_\_\_ mm Mounting side \_\_\_\_\_

**Colour**

Standard (RAL 7035, handle red RAL 3003)  Special colour (RAL) \_\_\_\_\_

**Other accessories**

- Disk mounting bay, mounting side \_\_\_\_\_
- Hinge set, mounting side \_\_\_\_\_
- Keyboard holder
- Document holder
- Separating strip, number \_\_\_\_\_
- Panel mounting for profile 1
- Panel mounting for profile 2
- Panel mounting for profile 3
- Fixing set 12-piece
- Fixing set 30-piece
- Quick fixing set
- Spring nut set
- Rubber cover narrow 7 mm
- Rubber cover narrow 5 mm



- + Aluminium profile compact commander in 2 widths
- + Integrated cooling system
- + External system groove
- + Variable profile lengths

### Included in delivery

Profile enclosure body, on rear side door or screwed wall; fastening elements for front panel; front panel order separately

## Technical data

<b>Material</b>	Enclosure profile: DIN EN 573 EN AW-AlMgSi Enclosure lid: DIN EN 1706 EN AC-AISI 12 (Fe)
<b>Painting</b>	Powder coating
<b>Colour</b>	Enclosure body and enclosure lid: RAL 7035, light grey Multi function profile: RAL 9005, jet black
<b>Ingress protection</b>	IP 65 to EN 60529
<b>Temperature range</b>	-30 °C to +65 °C



## Product range

Type	Order No.	Order No. Front plate	Weight (g)
CT 110-350-S	<b>20.80 10 10</b>	<b>20.80 91 01</b>	7000
CT 110-520-S	<b>20.80 10 20</b>	<b>20.80 91 02</b>	8500
CT 110-SL-S	<b>20.80 10 99</b>	<b>20.80 91 98</b>	-
CT 110-350-S-GT	<b>20.80 11 10</b>	<b>20.80 91 01</b>	7000
CT 110-520-S-GT	<b>20.80 11 20</b>	<b>20.80 91 02</b>	8500
CT 110-SL-S-GT	<b>20.80 11 99</b>	<b>20.80 91 98</b>	-
CT 145-350-S	<b>20.80 40 10</b>	<b>20.80 91 03</b>	9600
CT 145-520-S	<b>20.80 40 20</b>	<b>20.80 91 04</b>	11400
CT 145-SL-S	<b>20.80 40 99</b>	<b>20.80 91 99</b>	-
CT 145-350-S-GT	<b>20.80 42 10</b>	<b>20.80 91 03</b>	9600
CT 145-520-S-GT	<b>20.80 42 20</b>	<b>20.80 91 04</b>	11400
CT 145-SL-S-GT	<b>20.80 42 99</b>	<b>20.80 91 99</b>	-

SL = special length

### Suspension adaptation

for adaptation of ROSE suspension systems

- GT 48 and GTK electronic for ComTronic 110
- GTN II for ComTronic 145
- other machining by version "without coupling hole" available

Type	GT 48/2 GTS	GTK electronic	GTN II	without coupling hole
CT110-350-S				•
CT110-520-S				•
CT110-SL-S				•
CT110-350-S-GT	•	•		
CT110-520-S-GT	•	•		
CT110-SL-S-GT	•	•		
CT145-350-S				•
CT145-520-S				•
CT145-SL-S				•
CT145-350-S-GT			•	
CT145-520-S-GT			•	
CT145-SL-S-GT			•	

### Rear wall mounting

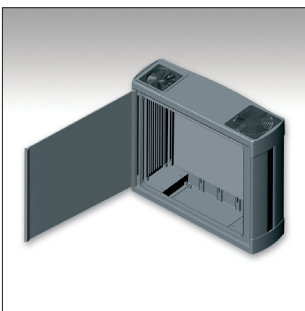

#### 1. Door with fast lock system

- Standard version
- Hinge side is fixed by pin screw with blind plugs
- Lock side is provided only by pin screws



#### 2. Door with turn bolt fastener

- Option available
- Hinge side is fixed by pin screw with blind plugs
- Lock side is provided with two turn bolt fasteners

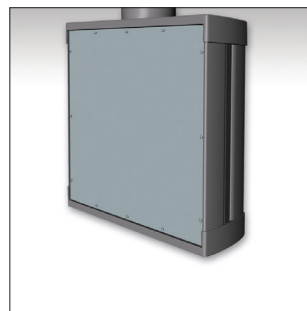

#### 3. Rear wall completely closed

- Optional available
- Rear wall fixed by screws

## Accessories

### Front plate

Order No.	Execution
<b>20.80 91 01</b>	for 20.80 10 10; 20.80 11 10
<b>20.80 91 02</b>	for 20.80 10 20; 20.80 11 20
<b>20.80 91 98</b>	for 20.80 10 98; 20.80 11 99
<b>20.80 91 03</b>	for 20.80 40 10; 20.80 42 10
<b>20.80 91 04</b>	for 20.80 40 20; 20.80 42 20
<b>20.80 91 99</b>	for 20.80 40 99; 20.80 42 99

### Handle set



Order No.	Execution
<b>20.80 90 02</b>	L = 350 mm (set = 2 pcs)
<b>20.80 90 03</b>	L = 500 mm (set = 2 pcs)
<b>20.80 90 99</b>	Special length (set = 2 pcs)

### Mounting set

Order No.	Execution
<b>10.03 31 01</b>	Mounting bracket set (4 brackets, spring nuts, screws)

### Cover plate

Order No.	Execution
<b>20.80 90 04</b>	for CT 110 (4 pcs)
<b>20.80 90 05</b>	for CT 145 (4 pcs)

### Wall holder



Order No.	Execution
<b>20.80 90 01</b>	

### Ventilator



Order No.	Execution
<b>83.90 00 04</b>	Ventilator 60 for ComTronic 110 (1 pc)
<b>83.90 00 05</b>	Ventilator 92 for ComTronic 145 (1 pc)

### NoVoTronic-adapter



Order No.	Execution
<b>20.80 90 06</b>	NoVoTronic-adapter P80
<b>20.80 90 07</b>	NoVoTronic-adapter P100
<b>20.80 90 08</b>	NoVoTronic-adapter P160

Further accessories see Commander system accessories



**Technical details**

Type	Order No.	Front plate W x H (mm)	Installation W x H (mm)	Enclosure W x H (mm)	Mounting depth	Enclosure depth
CT 110-350-S	<b>20.80 10 10</b>	266 x 350	255 x 336	365 x 442	91	118
CT 110-350-S-GT	<b>20.80 11 10</b>	266 x 350	255 x 336	365 x 442	91	118
CT 110-520-S	<b>20.80 10 20</b>	266 x 520	255 x 506	365 x 612	91	118
CT 110-520-S-GT	<b>20.80 11 20</b>	266 x 520	255 x 506	365 x 612	91	118
CT 110-SL-S	<b>20.80 10 99</b>	266 x SL	255 x SL	365 x SL	91	118
CT 110-SL-S-GT	<b>20.80 11 99</b>	266 x SL	255 x SL	365 x SL	91	118
CT 145-350-S	<b>20.80 40 10</b>	351 x 350	340 x 336	453 x 442	127	153
CT 145-350-S-GT	<b>20.80 42 10</b>	351 x 350	340 x 336	453 x 442	127	153
CT 145-520-S	<b>20.80 40 20</b>	351 x 520	340 x 506	453 x 612	127	153
CT 145-520-S-GT	<b>20.80 42 20</b>	351 x 520	340 x 506	453 x 612	127	153
CT 145-SL-S	<b>20.80 40 99</b>	351 x SL	340 x SL	453 x SL	127	153
CT 145-SL-S-GT	<b>20.80 42 99</b>	351 x SL	340 x SL	453 x SL	127	153

SL = Special length

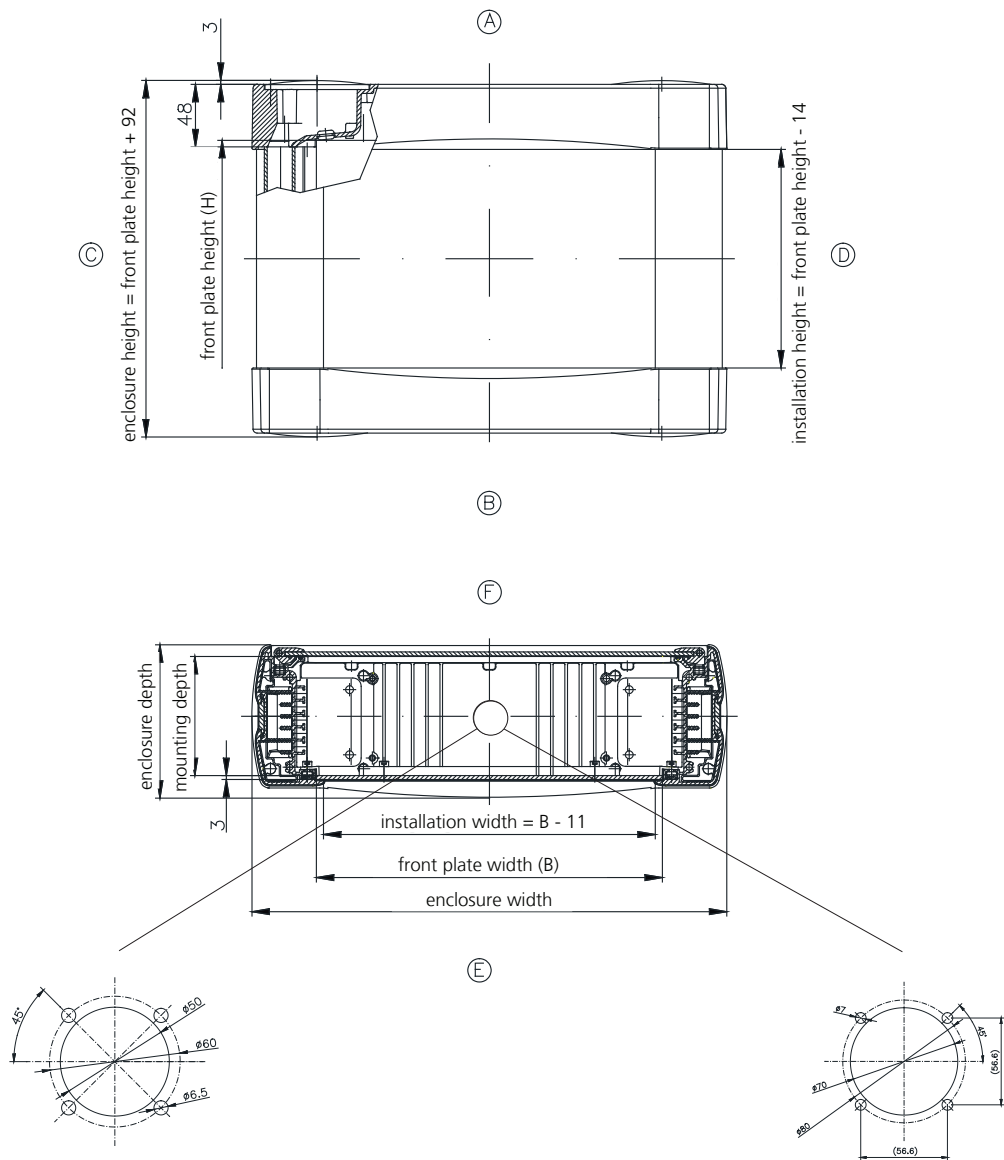

Drilling hole GT 48/2 and GTK electronic

Drilling hole GTN II

Company \_\_\_\_\_ Telephone \_\_\_\_\_

Contact \_\_\_\_\_ Telefax \_\_\_\_\_

Address \_\_\_\_\_ E-Mail \_\_\_\_\_

Project \_\_\_\_\_ Quantity \_\_\_\_\_ Lot size \_\_\_\_\_

**Dimensions operating enclosures**

- ComTronic 110  
 for front panel 266 x 350 mm (W x H)     for front panel 266 x 520 mm (W x H)  
 for front panel 266 x special length mm (W x H)

- ComTronic 145  
 for front panel 351 x 350 mm (W x H)     for front panel 351 x 520 mm (W x H)  
 for front panel 351 x special length mm (W x H)

front panel dimension special length H (mm) \_\_\_\_\_ (high)

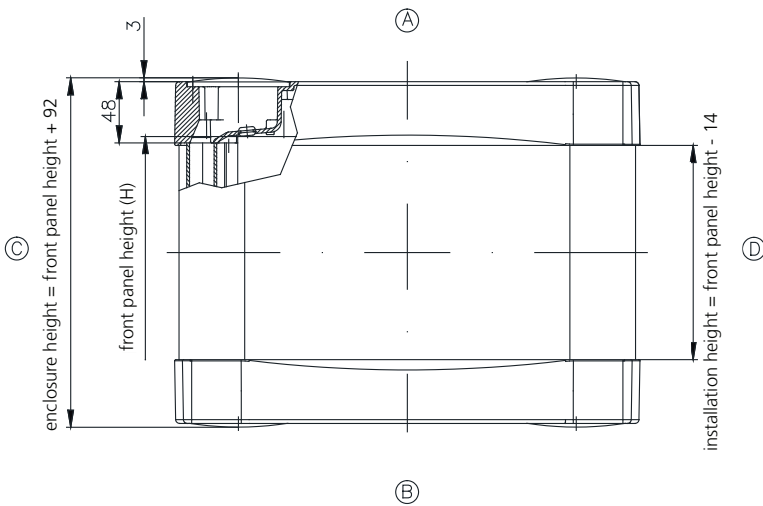

	110	145
Mounting depth:	91	127
Enclosure depth:	118	153
Installation width:	255	340

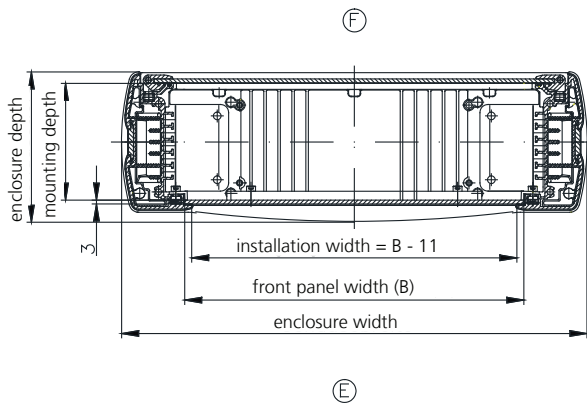

Front panel mounted:  yes  no

Modified acc. to drawing no.: \_\_\_\_\_

or specify manufacturer / control type \_\_\_\_\_



Accessory to inquiry / order

Company: \_\_\_\_\_

**Rear wall**

- With fast lock system (standard)
  - With turn bolt fastener
  - Square 6 mm (standard)
  - Screwed
  - Rear wall machining acc. drawing no. \_\_\_\_\_
- Hinged side \_\_\_\_\_ (standard side D)
  - Hinged side \_\_\_\_\_ (standard side D)
  - Triangular 6,5 mm
  - Slot 1,5 mm

**Colour**

- Standard: light grey, RAL 7035
- Special colour (please specify RAL colour single):  
 Profile RAL \_\_\_\_\_ Lid RAL \_\_\_\_\_ Slot-in strip RAL \_\_\_\_\_ (standard: black)

**Suspension system**

- without
  - GTK electronic or GT 48/2 Side \_\_\_\_\_ (standard side A by ComTronic 110)
  - GTS Side \_\_\_\_\_ (standard side A by ComTronic 110)
  - GTN II Side \_\_\_\_\_ (standard side A by ComTronic 110)
  - Moterm
  - other \_\_\_\_\_ Drawing no. \_\_\_\_\_ Side \_\_\_\_\_
- Total weight of mountings ca. \_\_\_\_\_ kg

**Handle set**

- Side C and D
- Special colour RAL \_\_\_\_\_ (standard: black)
- Special length \_\_\_\_\_ mm

**Ventilator (1 pcs.)**

- Standard 2 pcs.
- Side \_\_\_\_\_ (standard: side A)  
 divergent by inset of only one ventilator

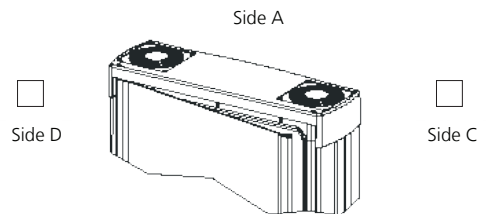

**Cover elements (4 pcs.)**

- (or hygienic areas) attention: none optimal cooling effect!

**NoVoTronic adapter**

- Side \_\_\_\_\_ (standard: side D)

**Wall holder-CT**

- Side \_\_\_\_\_ (standard: Side C)

**Other machining / special versions**

\_\_\_\_\_

\_\_\_\_\_

acc. drawing no.: \_\_\_\_\_



# Commander 1

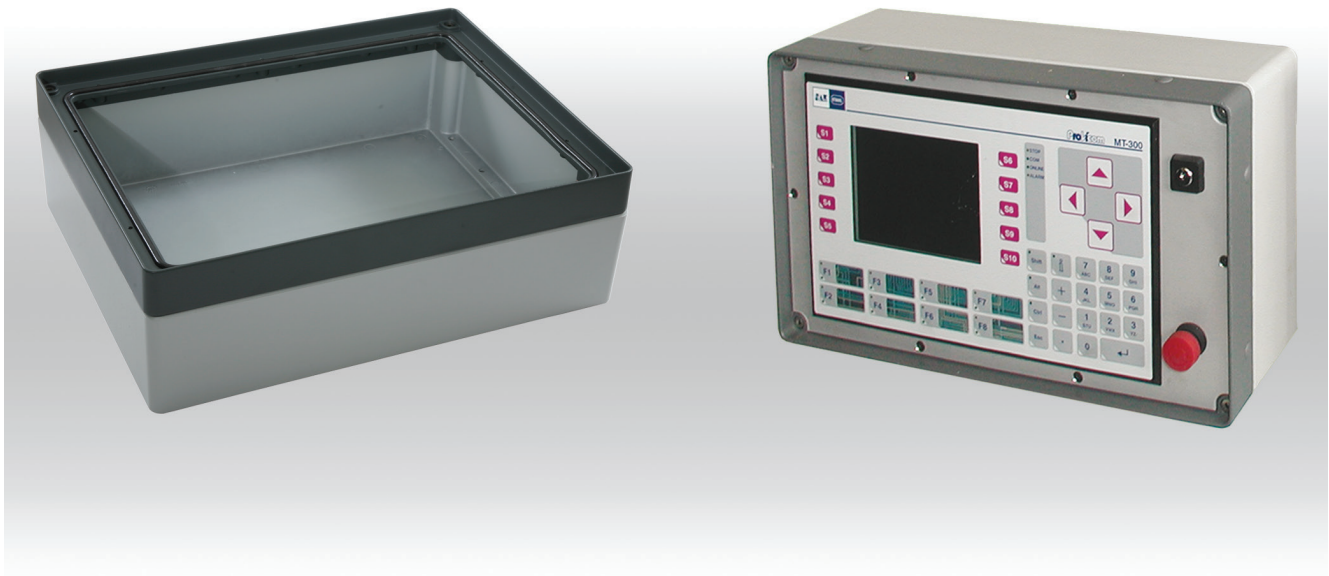

- + Small control enclosure in aluminium diecast with protective bumperbars
- + Robust aluminium diecast enclosure body with front panel
- + Transparent cover and handle set (optional)
- + High protection class IP 65

### Included in delivery





Enclosure body with front frame and fastening screws (2 or 4 pcs.).  
Please order front panel separately

## Technical data

<b>Material</b>	DIN EN 1706 EN AC-AISI 12 (Fe)
<b>Painting</b>	Powder coating
<b>Colour</b>	Enclosure body: RAL 7038, agate grey Front frame: RAL 7043, traffic grey B Special colour on request
<b>Ingress protection</b>	IP 65 to EN 60529 with transparent cover IP 54



## Product range

Type	Dimensions H x W x D (mm)	Enclosure without front panel	Enclosure drilled for attachment of handle, without front panel	Weight (g)	1 set single handle for side A + B 	1 set single handle for side C + D 	Handling frame for side A + B 	Handling frame for side C + D 
13.05	230 x 100 x 128	13.05 00 00		2170				
13.07	260 x 160 x 108	13.07 00 00		2450				
13.08	360 x 160 x 108	13.08 00 00		2730				
13.09	560 x 160 x 108	13.09 00 00		5390				
13.10	230 x 200 x 128	13.10 00 00	13.10 10 00	3100	13.34 00 01	13.34 00 01		13.34 10 01
13.11	230 x 200 x 198	13.11 00 00	13.11 10 00	4495	13.34 00 01	13.34 00 01		13.34 10 01
13.12	230 x 330 x 128	13.12 00 00	13.12 10 00	4280	13.34 00 03	13.34 00 01	13.34 12 02	13.34 12 01
13.13	230 x 330 x 198	13.13 00 00	13.13 10 00	6000	13.34 00 03	13.34 00 01	13.34 12 02	13.34 12 01
13.14	230 x 400 x 128	13.14 00 00	13.14 10 00	5305	13.34 00 04	13.34 00 01	13.34 14 02	13.34 14 01
13.15	230 x 400 x 242	13.15 00 00	13.15 10 00	6840	13.34 00 04	13.34 00 01	13.34 14 02	13.34 14 01
13.17	230 x 280 x 130	13.17 00 00	13.17 10 00	4000	13.34 00 02	13.34 00 01		
13.20	310 x 400 x 128	13.20 00 00	13.20 10 00	5200	13.34 00 04	13.34 00 02	13.34 20 02	13.34 20 01
13.21	310 x 400 x 198	13.21 00 00	13.21 10 00	8215	13.34 00 04	13.34 00 02	13.34 20 02	13.34 20 01
13.22	310 x 600 x 128	13.22 00 00	13.22 10 00	9720	13.34 00 05	13.34 00 02	13.34 22 02	13.34 22 01
13.23	310 x 600 x 198	13.23 00 00	13.23 10 00	10300	13.34 00 05	13.34 00 02	13.34 22 02	13.34 22 01
13.24	310 x 400 x 244	13.24 00 00	13.24 10 00	8700	13.34 00 04	13.34 00 02	13.34 20 02	13.34 20 01
13.25	310 x 400 x 158	13.25 00 00	13.25 10 00	7085	13.34 00 04	13.34 00 02	13.34 20 02	13.34 20 01

## Connection to suspension system

for type	GT 48/2 GTK electronic	GTS	GT 50/2	GT 60/2 GTN II	GT 80/2
13.05	•				
13.07	•				
13.08	•				
13.09	•				
13.10	•	•	•		
13.11	•	•	•	•	•
13.12	•	•	•		
13.13	•	•	•	•	•
13.14	•	•	•		
13.15	•	•	•	•	•
13.17	•	•	•		
13.20	•	•	•		
13.21	•	•	•	•	•
13.22	•	•	•		
13.23	•	•	•	•	•
13.24	•	•	•	•	•
13.25	•	•	•	•	•

# Commander 1

## Accessories

Type	Front plate	Mounting plate	Transparent cover with knurled lock	DIN rail TS 35/7.5	Silicone seal
13.05	10.01 30 05	10.01 10 14		10.06 14 29	10.05 10 15
13.07	10.01 30 07	10.01 10 11		10.06 14 24	10.05 13 07
13.08	10.01 30 08	10.01 10 12		10.06 14 25	10.05 13 08
13.09	10.01 30 09	10.01 10 13		10.06 14 26	10.05 13 09
13.10	10.01 30 10	10.01 10 15	13.33 10 10	10.06 14 30	10.05 13 10
13.11	10.01 30 10	10.01 10 15	13.33 10 10	10.06 14 30	10.05 13 10
13.12	10.01 30 12	10.01 10 17	13.33 12 10	10.06 14 32	10.05 13 12
13.13	10.01 30 12	10.01 10 17	13.33 12 10	10.06 14 32	10.05 13 12
13.14	10.01 30 14	10.01 10 18	13.33 14 10	10.06 14 27	10.05 13 14
13.15	10.01 30 14	10.01 10 18	13.33 14 10	10.06 14 27	10.05 13 14
13.17	10.01 30 17	10.01 10 16		10.06 14 31	10.05 13 17
13.20	10.01 30 20	10.01 10 20	13.33 20 10	10.06 14 27	10.05 13 20
13.21	10.01 30 20	10.01 10 20	13.33 20 10	10.06 14 27	10.05 13 20
13.22	10.01 30 22	10.01 10 21	13.33 22 10	10.06 14 28	10.05 13 22
13.23	10.01 30 22	10.01 10 21	13.33 22 10	10.06 14 28	10.05 13 22
13.24	10.01 30 20	10.01 10 20	13.33 20 10	10.06 14 27	10.05 13 20
13.25	10.01 30 20	10.01 10 20	13.33 20 10	10.06 14 27	10.05 13 20

### Internal hinge



Swivel range 95°  
set = 2 pcs

Order No.

**10.02 20 01**

### External hinge



Swivel range 150°  
set = 2 pcs

Order No.

**10.02 70 43**

### Lock



Order No.

Execution

**10.12 04 07**

Square 7 mm

**10.12 04 08**

Square 8 mm

**10.12 04 09**

Triangular 7 mm

**10.12 04 10**

Triangular 8 mm

**10.12 04 11**

Daimler Benz

**10.12 04 12**

Double ward

**10.12 04 13**

Knob with lock



Accessories

Front plate

Type	Order No.	A	B	Installation width	Installation height
13.05	<b>10.01 30 05</b>	90,5	220,5	80	210

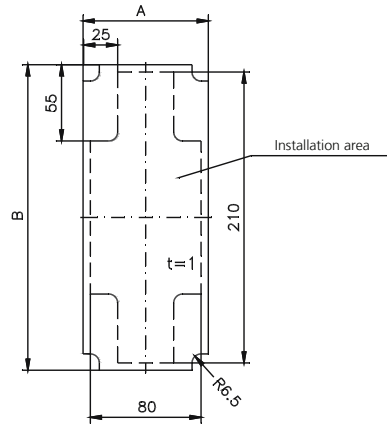

Front plate

Type	Order No.	A	B	C	D	E	F	Installation width	Installation height
13.07	<b>10.01 30 07</b>	251	151	205	140	240	-	220	120
13.08	<b>10.01 30 08</b>	351	151	305	140	340	-	320	120
13.10	<b>10.01 30 10</b>	192,5	223	-	210	179	-	154	184
13.11	<b>10.01 30 10</b>	192,5	223	-	210	179	-	154	184
13.12	<b>10.01 30 12</b>	320,5	220,5	140	207	307	-	284	184
13.13	<b>10.01 30 12</b>	320,5	220,5	140	207	307	-	284	184
13.14	<b>10.01 30 14</b>	389,5	219	140	207	377	-	354	184
13.15	<b>10.01 30 14</b>	389,5	219	140	207	377	-	354	184
13.17	<b>10.01 30 17</b>	272	222	-	208	258	-	234	184
13.20	<b>10.01 30 20</b>	390,5	300,5	300	287	377	150	354	264
13.21	<b>10.01 30 20</b>	390,5	300,5	300	287	377	150	354	264
13.24	<b>10.01 30 20</b>	390,5	300,5	300	287	377	150	354	264
13.25	<b>10.01 30 20</b>	390,5	300,5	300	287	377	150	354	264

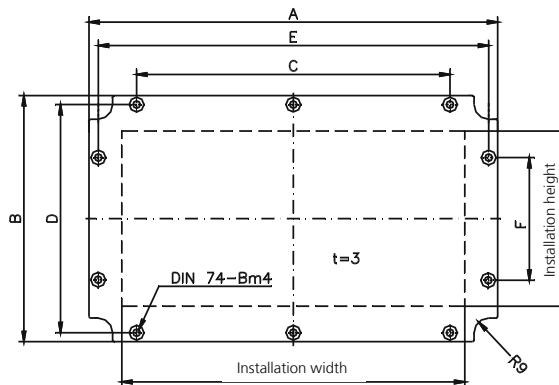

# Commander 1

## Accessories

### Front plate

Type	Order No.	A	B	C	D	E	F	G	Installation width	Installation height
13.09	<b>10.01 30 09</b>	551	151	505	140	540	-	175	516	120
13.22	<b>10.01 30 22</b>	590,5	300,5	450	287	577	150	150	554	264
13.23	<b>10.01 30 22</b>	590,5	300,5	450	287	577	150	150	554	264

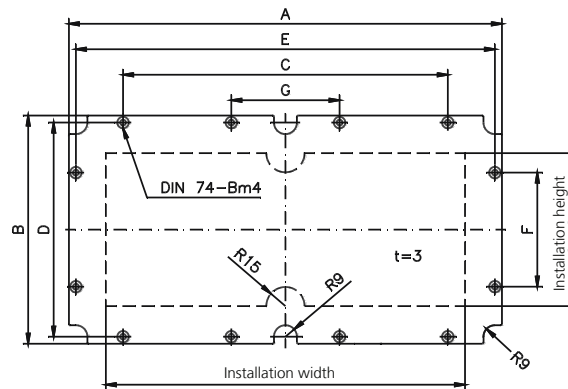

## Technical details

Order No.	b	h	t	b1	h1	t1	a
<b>13.05 00 00</b>	100	230	129	88	218	101	14
<b>13.10 00 00</b>	202	232	129	189	219	108	13
<b>13.11 00 00</b>	202	232	198	190	220	176	14

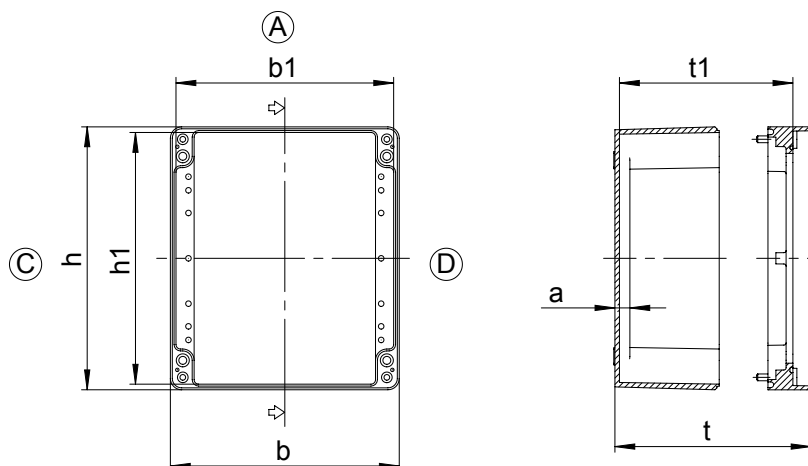

Technical details

Order No.	b	h	t	b1	h1	t1	a
13.07 00 00	260	160	109	248,5	149	88	13
13.08 00 00	360	160	109	348,5	149	88	13
13.09 00 00	560	160	109	548,5	149	88 <td 13	
13.12 00 00	330	230	129	316,5	216,5	112	13
13.13 00 00	330	230	199	316,5	216,5	176	15
13.14 00 00	400	230	129	387	217	108	13
13.15 00 00	400	230	243	384,5	214,5	220,5	14
13.17 00 00	280	230	129	387	217	108	13
13.20 00 00	404	313	129	391	301	107,5	13
13.21 00 00	404	313	199	358,5	299	176	14
13.22 00 00	600	310	129	586	296	106	14
13.23 00 00	600	310	199	584	294	176	14
13.24 00 00	404	313	245	360,5	297,5	222	14
13.25 00 00	403	312	159	391	296,5	136	14

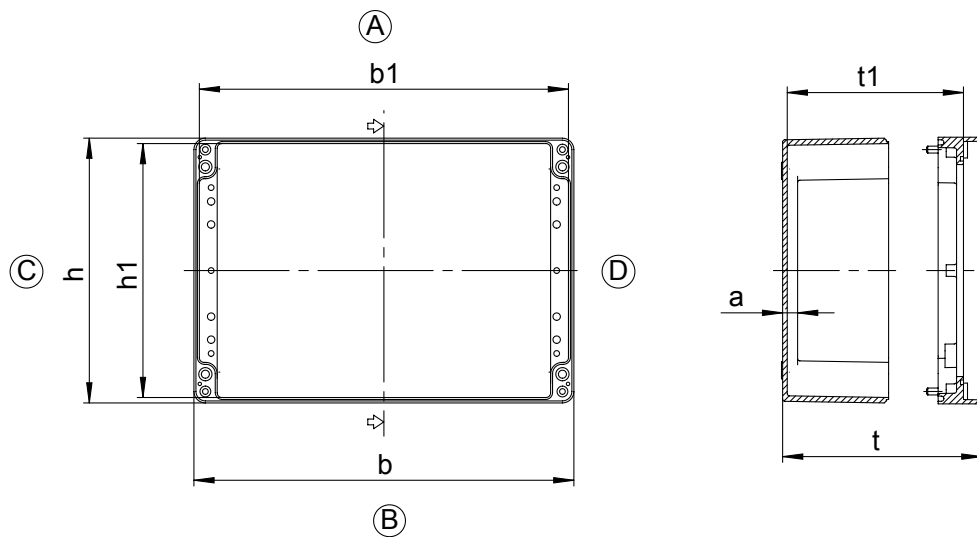

# Commander 1F

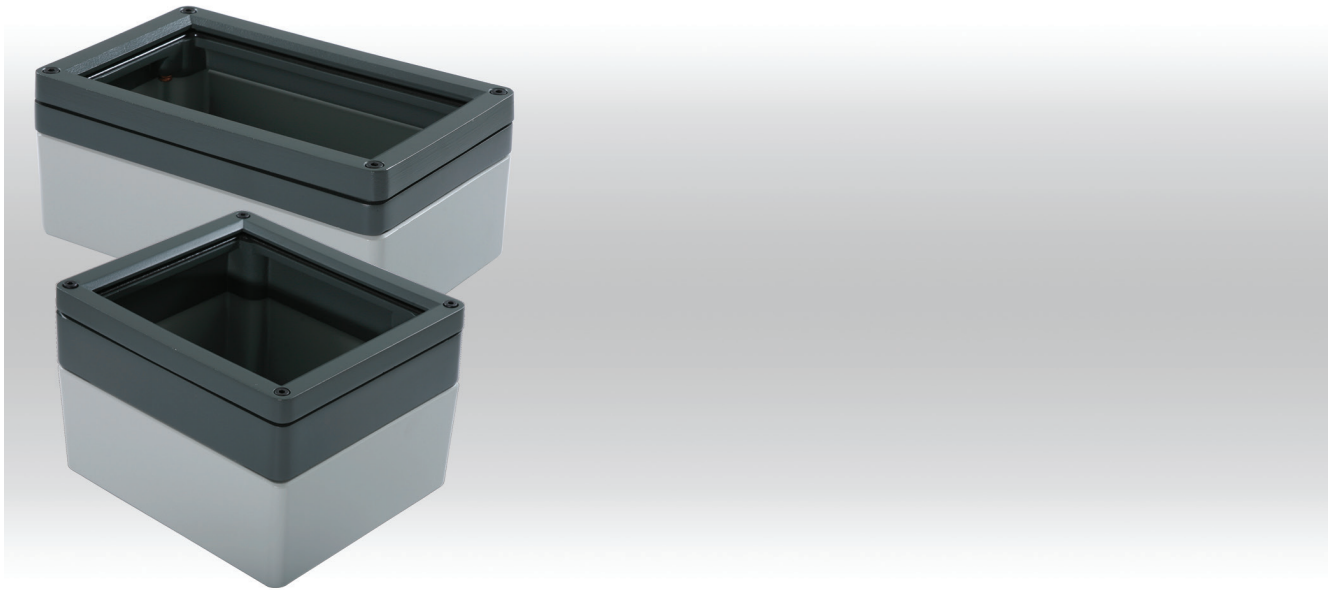

- + Small control enclosure in aluminium with front frame for front panels and keypads
- + Robust aluminium diecast enclosure body
- + Handle set (optional)
- + High protection class IP 65

## Included in delivery





Enclosure body with two-part front frame, enclosure and fastening screws (2 or 4 pcs.).  
Please order front panel separately

## Technical data

<b>Material</b>	DIN EN 1706 EN AC-AISI 12 (Fe)
<b>Painting</b>	Powder coating
<b>Colour</b>	Enclosure body: RAL 7038, agate grey Front frame: RAL 7043, trafic grey B Special colours on request
<b>Ingress protection</b>	IP 65 to EN 60529



## Product range

Type	Dimensions H x W x D (mm)	Enclosure without front panel	Enclosure drilled for attachment of handle, without front panel	Weight (g)	1 set single handle for side A + B 	1 set single handle for side C + D 	Handling frame for side A + B 	Handling frame for side A + B 
<b>13.07</b>	260 x 160 x 108	<b>13.07 05 00</b>		3000				
<b>13.08</b>	360 x 160 x 108	<b>13.08 05 00</b>		3581				
<b>13.10</b>	230 x 200 x 128	<b>13.10 05 00</b>	<b>13.10 15 00</b>	3900	<b>13.34 00 01</b>	<b>13.34 00 01</b>		<b>13.34 10 01</b>
<b>13.10</b>	230 x 200 x 153	<b>13.10 05 10</b>	<b>13.10 15 10</b>	3610	<b>13.34 00 01</b>	<b>13.34 00 01</b>		<b>13.34 10 01</b>
<b>13.11</b>	230 x 200 x 198	<b>13.11 05 00</b>	<b>13.11 15 00</b>	4470	<b>13.34 00 01</b>	<b>13.34 00 01</b>		<b>13.34 10 01</b>
<b>13.12</b>	230 x 330 x 128	<b>13.12 05 00</b>	<b>13.12 15 00</b>	4300	<b>13.34 00 03</b>	<b>13.34 00 01</b>	<b>13.34 12 02</b>	<b>13.34 12 01</b>
<b>13.12</b>	230 x 330 x 153	<b>13.12 05 10</b>	<b>13.12 15 10</b>	4685	<b>13.34 00 03</b>	<b>13.34 00 01</b>	<b>13.34 12 02</b>	<b>13.34 12 01</b>
<b>13.13</b>	230 x 330 x 198	<b>13.13 05 00</b>	<b>13.13 15 00</b>	7500	<b>13.34 00 03</b>	<b>13.34 00 01</b>	<b>13.34 12 02</b>	<b>13.34 12 01</b>
<b>13.14</b>	230 x 400 x 128	<b>13.14 05 00</b>	<b>13.14 15 00</b>	4580	<b>13.34 00 04</b>	<b>13.34 00 01</b>	<b>13.34 14 02</b>	<b>13.34 14 01</b>
<b>13.15</b>	230 x 400 x 242	<b>13.15 05 00</b>	<b>13.15 15 00</b>	7230	<b>13.34 00 04</b>	<b>13.34 00 01</b>	<b>13.34 14 02</b>	<b>13.34 14 01</b>
<b>13.17</b>	230 x 280 x 130	<b>13.17 05 00</b>	<b>13.17 15 00</b>	4200	<b>13.34 00 02</b>	<b>13.34 00 01</b>		
<b>13.20</b>	310 x 400 x 128	<b>13.20 05 00</b>	<b>13.20 15 00</b>	6700	<b>13.34 00 04</b>	<b>13.34 00 02</b>	<b>13.34 20 02</b>	<b>13.34 20 01</b>
<b>13.21</b>	310 x 400 x 198	<b>13.21 05 00</b>	<b>13.21 15 00</b>	9280	<b>13.34 00 04</b>	<b>13.34 00 02</b>	<b>13.34 20 02</b>	<b>13.34 20 01</b>
<b>13.25</b>	310 x 400 x 158	<b>13.25 05 00</b>	<b>13.25 15 00</b>	7085	<b>13.34 00 04</b>	<b>13.34 00 02</b>	<b>13.34 20 02</b>	<b>13.34 20 01</b>

## Connection to suspension system

for type	GTK electronic GT 48/2	GTS	GT 50/2	GT 50/2	GT 60/2 GTN II	GT 80/2
<b>13.07 05 00</b>	•	•				
<b>13.08 05 00</b>	•	•				
<b>13.10 05 00</b>	•	•	•	•		
<b>13.10 05 10</b>	•	•	•	•		
<b>13.11 05 00</b>	•	•	•	•	•	•
<b>13.12 05 00</b>	•	•	•	•		
<b>13.12 05 10</b>	•	•	•	•		
<b>13.13 05 00</b>	•	•	•	•	•	•
<b>13.14 05 00</b>	•	•	•	•		
<b>13.15 05 00</b>	•	•	•	•	•	•
<b>13.17 05 00</b>	•	•	•	•		
<b>13.20 05 00</b>	•	•	•	•		
<b>13.21 05 00</b>	•	•	•	•	•	•
<b>13.25 05 00</b>	•	•	•	•	•	•



# Commander 1F

## Accessories

Type	Front plate	Mounting plate	DIN rail TS 35/7.5	Silicone seal
13.07	<b>10.01 32 07</b>	<b>10.01 10 11</b>	<b>10.06 14 24</b>	<b>10.05 13 07</b>
13.08	<b>10.01 32 08</b>	<b>10.01 10 12</b>	<b>10.06 14 25</b>	<b>10.05 13 08</b>
13.10	<b>10.01 32 10</b>	<b>10.01 10 15</b>	<b>10.06 14 30</b>	<b>10.05 13 10</b>
13.11	<b>10.01 32 10</b>	<b>10.01 10 15</b>	<b>10.06 14 30</b>	<b>10.05 13 10</b>
13.12	<b>10.01 32 12</b>	<b>10.01 10 17</b>	<b>10.06 14 32</b>	<b>10.05 13 12</b>
13.13	<b>10.01 32 12</b>	<b>10.01 10 17</b>	<b>10.06 14 32</b>	<b>10.05 13 12</b>
13.14	<b>10.01 32 14</b>	<b>10.01 10 18</b>	<b>10.06 14 27</b>	<b>10.05 13 14</b>
13.15	<b>10.01 32 14</b>	<b>10.01 10 18</b>	<b>10.06 14 27</b>	<b>10.05 13 14</b>
13.17	<b>10.01 32 17</b>	<b>10.01 10 16</b>	<b>10.06 14 31</b>	<b>10.05 13 17</b>
13.20	<b>10.01 32 20</b>	<b>10.01 10 20</b>	<b>10.06 14 27</b>	<b>10.05 13 20</b>
13.21	<b>10.01 32 20</b>	<b>10.01 10 20</b>	<b>10.06 14 27</b>	<b>10.05 13 20</b>
13.25	<b>10.01 32 20</b>	<b>10.01 10 20</b>	<b>10.06 14 27</b>	<b>10.05 13 20</b>

### Internal hinge



Swivel range 95°  
set = 2 pcs

Order No.

**10.02 20 01**

Execution

only for type 13.07 to 13.15

### External hinge



Swivel range 150°  
set = 2 pcs

Order No.

**10.02 70 43**

### Lock



Order No.

**10.12 04 07**

Execution

Square 7 mm

**10.12 04 08**

Square 8 mm

**10.12 04 09**

Triangular 7 mm

**10.12 04 10**

Triangular 8 mm

**10.12 04 11**

Daimler Benz

**10.12 04 12**

Double ward

**10.12 04 13**

Knob with lock



Accessories

Front plate

Type	Order No.	A	B	Installation width	Installation height
13.07F	<b>10.01 32 07</b>	230	130	215	115
13.08F	<b>10.01 32 08</b>	330	130	315	115
13.10F	<b>10.01 32 10</b>	170	200	155	185
13.11F	<b>10.01 32 10</b>	170	200	155	185
13.12F	<b>10.01 32 12</b>	300	200	285	185
13.13F	<b>10.01 32 12</b>	300	200	285	185
13.14F	<b>10.01 32 14</b>	370	200	355	185
13.15F	<b>10.01 32 14</b>	370	200	355	185
13.17F	<b>10.01 32 17</b>	251	201	235	185
13.20F	<b>10.01 32 20</b>	375	284	359	268
13.21F	<b>10.01 32 20</b>	375	284	359	268
13.25F	<b>10.01 32 20</b>	375	284	359	268

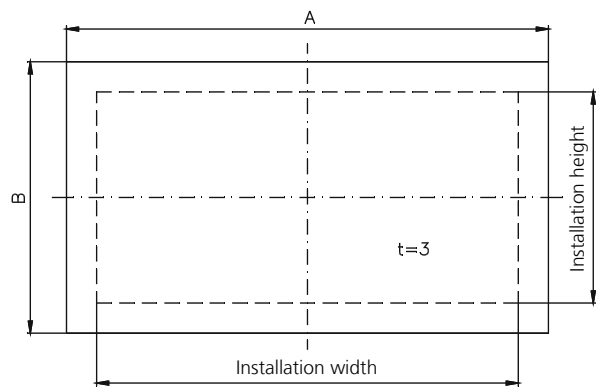

Technical details

Order No.	b	h	t	b1	h1	t1	a
<b>13.10 05 00</b>	202	232	129,5	189	219	113,5	13
<b>13.10 05 10</b>	202	232	153	189	219	137	13
<b>13.11 05 00</b>	202	232	198,5	190	220	181,5	14

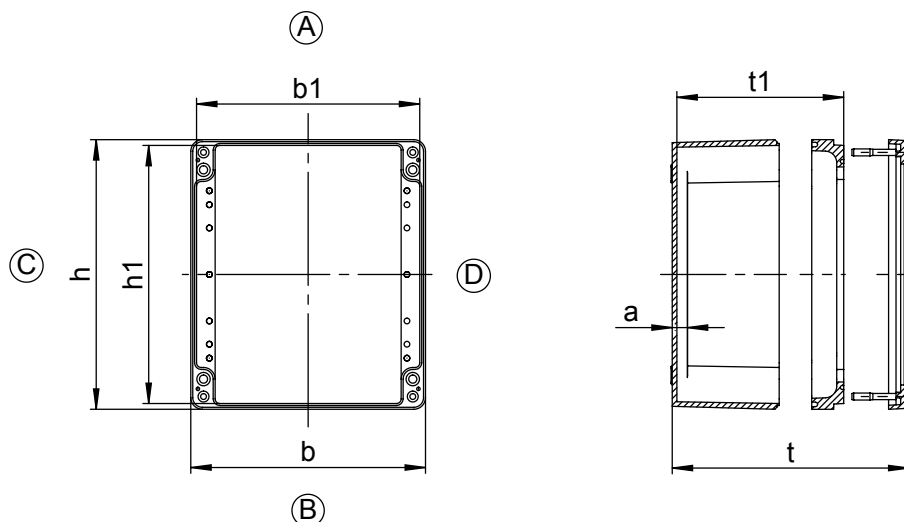

# Commander 1F

## Technical details

Order No.	b	h	t	b1	h1	t1	a
<b>13.07 05 00</b>	260	160	109,5	248,5	149	93,5	13
<b>13.08 05 00</b>	360	160	109,5	348,5	149	93,5	13
<b>13.12 05 00</b>	330	230	129,5	320,5	220,5	113,5	13
<b>13.12 05 10</b>	330	230	153	320,5	220,5	137	13
<b>13.13 05 00</b>	330	230	199,5	320,5	220,5	181,5	15
<b>13.14 05 00</b>	400	230	129,5	384,5	214,5	113,5	13
<b>13.15 05 00</b>	400	230	243,5	384,5	214,5	226	14
<b>13.17 05 00</b>	280	230	129,5	268	218	113,5	13
<b>13.20 05 00</b>	404	313	129,5	390	299	113	13
<b>13.21 05 00</b>	404	313	199,5	390	299	181,5	14
<b>13.25 05 00</b>	403	312	159,5	388,5	296,5	141,5	14

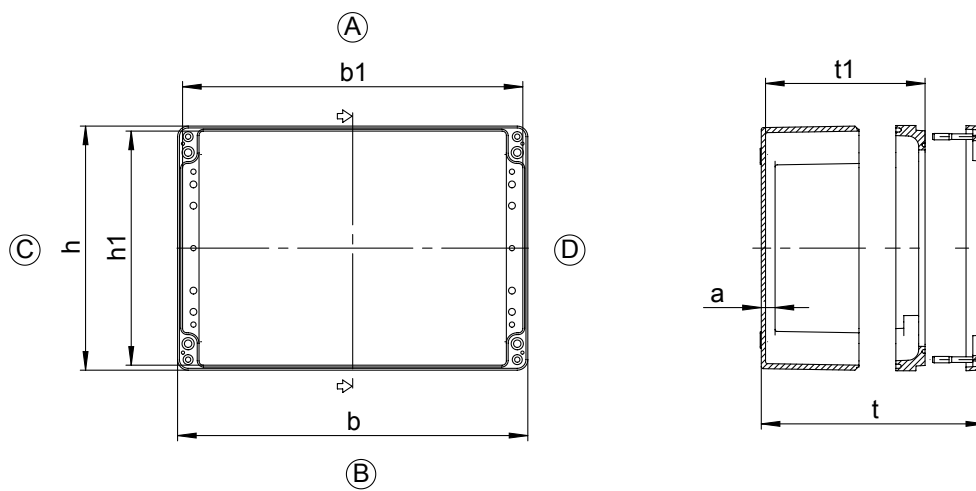



- + Stainless steel control enclosure based on switch gear cabinet KSS
- + Including reinforcement plate and drill hole for ROSE GTH suspension system
- + Optional individual sizes and Executions from 25 off

**Included in delivery**

Enclosure system including amplifier plate and GTH coupling hole with door, double ward lock.

**Technical data**

<b>Material</b>	Stainless steel 1.25 mm or 1.5 mm; 1.4301 / 304
<b>Surface</b>	grinded, grain 240
<b>Seal</b>	VMQ (silicone) EMC on request
<b>Ingress protection</b>	IP 65 to EN 60529
<b>Temperature range</b>	-40 °C to +80 °C

# Commander KSSC

## Product range

Order No.	Weight (g)	Dimensions (mm)								Drillings for suspension system (side A)
		A	B	C	D	E	S	H <sub>U</sub>	H <sub>Ges</sub>	
<b>37.02 23 15</b>	3500	200	300	24,6	160	100	1.25	130,7	155	GTH 48 (Bild 1)
<b>37.02 34 21</b>	6000	300	380	24,6	260	175	1.25	185,7	210	GTH 48 (Bild 1)
<b>37.02 43 15</b>	5500	400	300	24,6	360	100	1.25	130,7	155	GTH 48 (Bild 1)
<b>37.02 46 21</b>	11500	380	600	25,1	340	175	1.5	185,7	210	GTH 60 (Bild 2)
<b>37.02 55 21</b>	10500	500	500	24,6	460	175	1.25	185,7	210	GTH 60 (Bild 2)
<b>37.02 64 15</b>	10500	600	400	25,1	460	120	1.5	130,7	155	GTH 60 (Bild 2)
<b>37.02 68 21</b>	19500	600	760	25,1	560	175	1.5	185,7	210	GTH 60 (Bild 2)
<b>37.02 99 00</b>		special size (acc. specification)								

Cutout of size, state by order  
 Special size: from 25 pcs/order

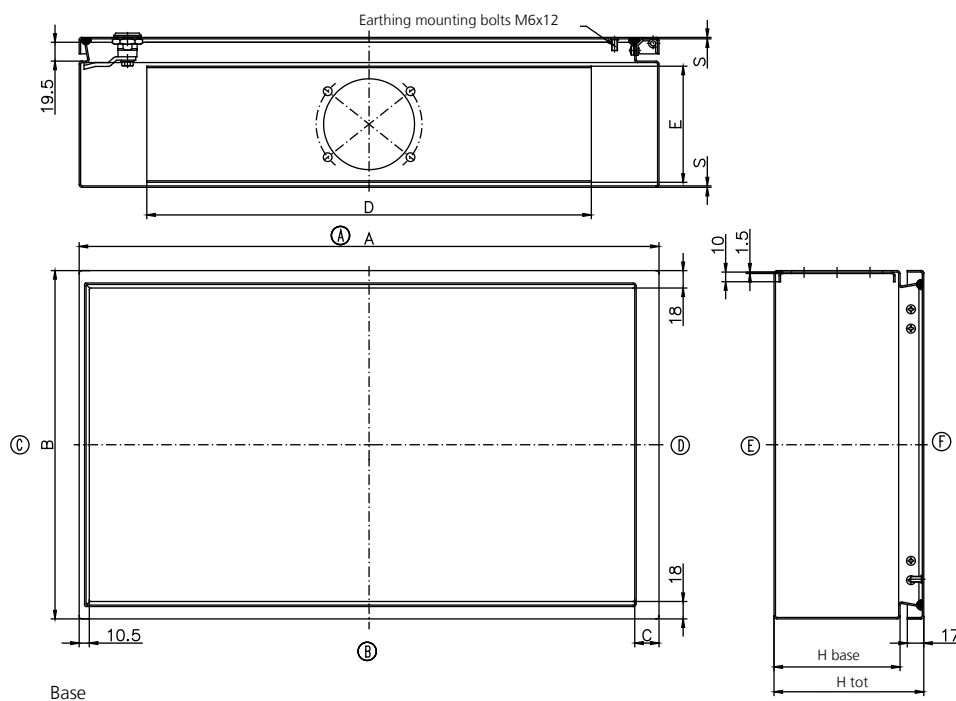

Picture 1:  
Coupling drilling hole (GTH 48)

Picture 2:  
Coupling drilling hole (GTH 60)

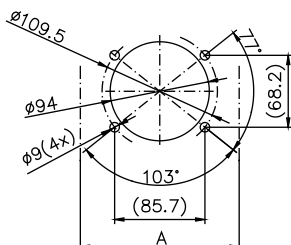
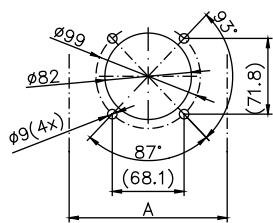

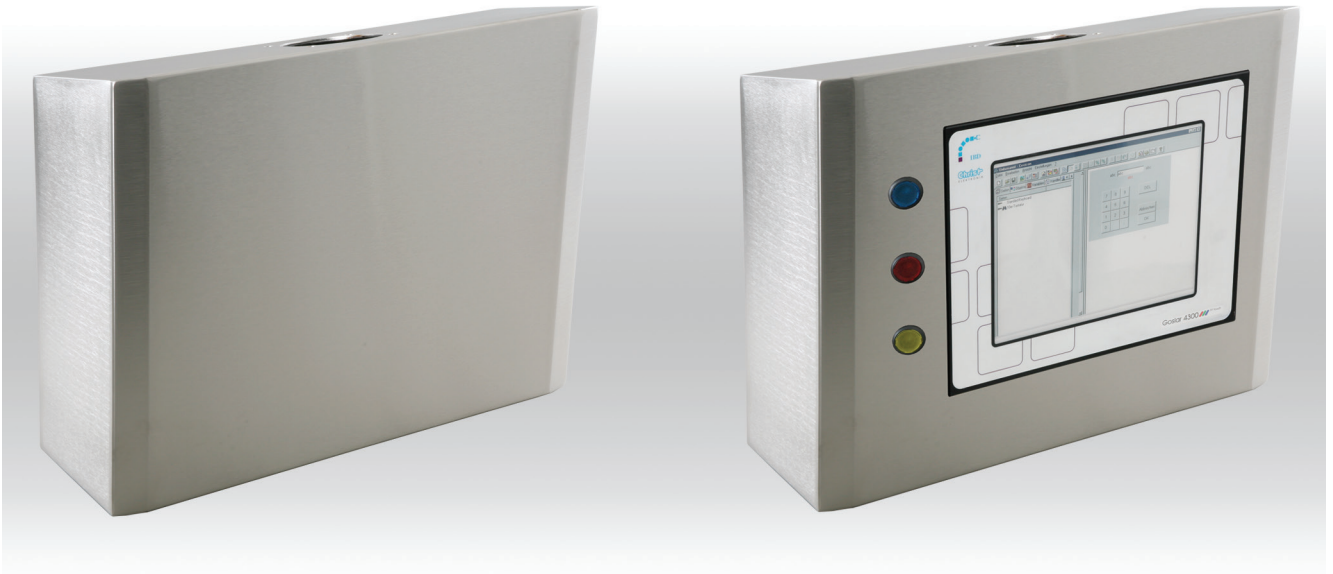

- + Stainless steel Commander with screwed rear wall
- + Sloped top acc. to hygienic design regulations
- + High material quality

### Included in delivery

Enclosure with screwed rear wall, silicone seal - depending on Execution with closed or individual manufactured front, internal fixing and coupling hole for suspension system GTH 48

### Technical data

<b>Material</b>	Stainless steel 1.4404/316L
<b>Surface</b>	grinded, grain 240
<b>Seal</b>	Silicone
<b>Ingress protection</b>	IP 66 / IP 69K to EN 60529
<b>Temperature range</b>	-40 °C to +80 °C

# Commander 410

## Product range

Order No.	Dimensions (mm) W x H x D	Z	Fitting width	Fitting height	Drillings for suspension system (Side A)	Weight (g)
56.10 02 01	380 x 250 x 150	37	320	245	GTH 48	9000
56.10 02 02	380 x 250 x 220	55	320	245	GTH 48	9000
56.10 02 03	500 x 350 x 150	37	440	345	GTH 48	11000
56.10 02 04	500 x 350 x 220	55	440	345	GTH 48	11500
56.10 02 05	500 x 450 x 150	37	440	445	GTH 48	12000
56.10 02 06	500 x 450 x 220	55	440	445	GTH 48	12500

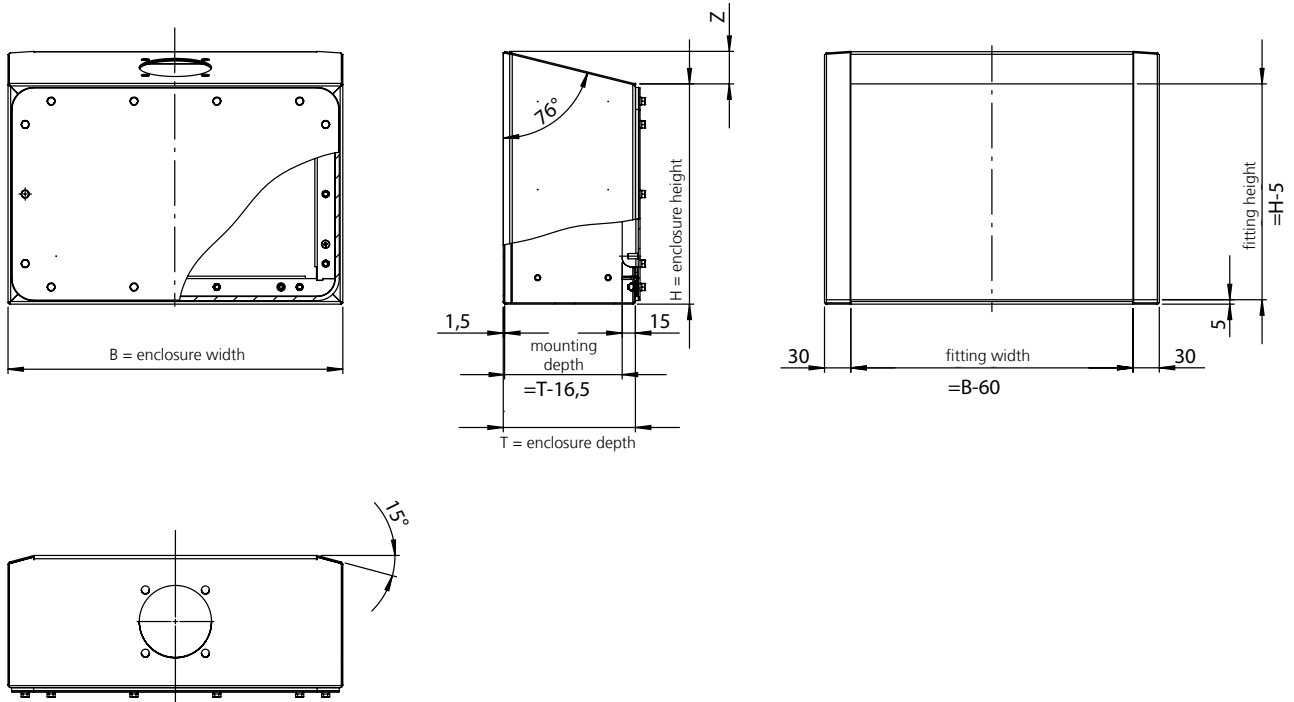

## Accessories

### Mounting angle set

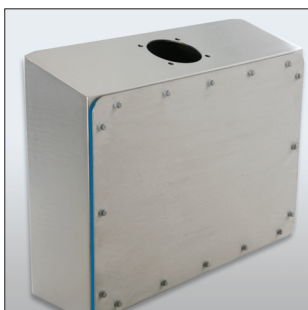

Order No.	Execution
56.20 99 01	for internal fitting of components



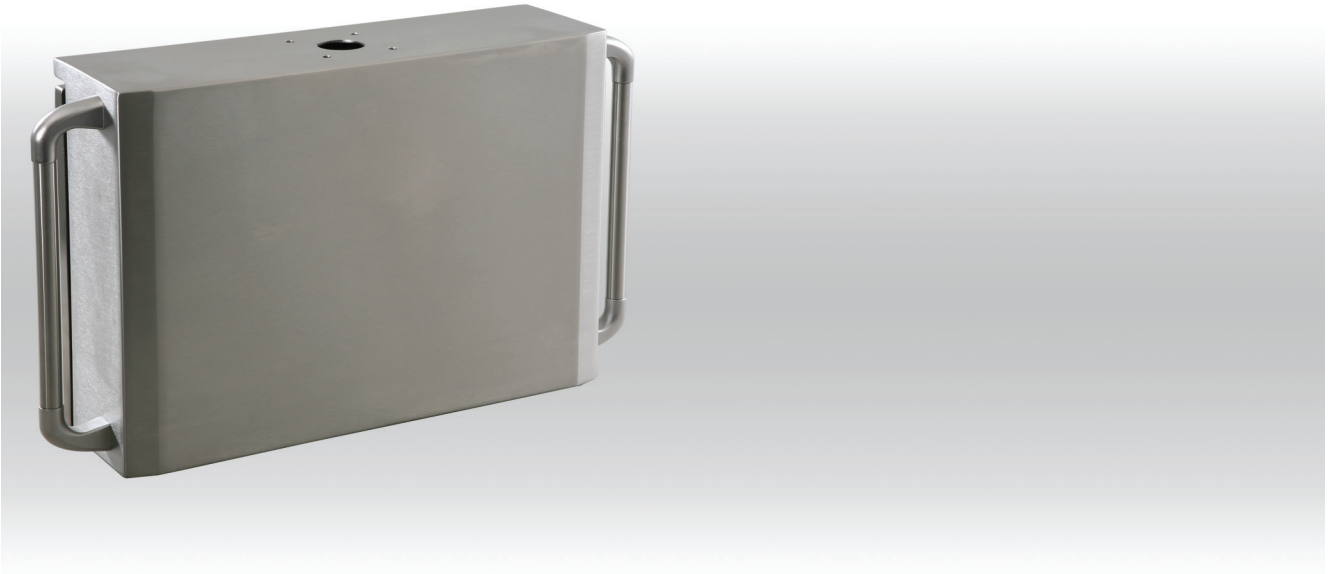

- + Stainless steel Commander with door for industrial applications
- + High material quality
- + Handle set optional

### Included in delivery

Enclosure with door, rect angle, silicone seal - depending on Execution with closed or individual manufactured front, internal fixing and coupling hole for suspension system GTH 48

### Technical data

<b>Material</b>	Stainless steel 1.4301/304 other materials on request
<b>Surface</b>	grinded, grain 240
<b>Seal</b>	Silicone
<b>Ingress protection</b>	IP 65 to EN 60529
<b>Temperature range</b>	-40 °C to +80 °C



# Commander 420

## Product range

Order No.	Dimensions (mm) W x H x D	Fitting width	Fitting height	Drillings for suspension system (Side A)	Weight (g)
<b>56.20 01 01</b>	380 x 250 x 150	338	240	GTH 48	9000
<b>56.20 01 02</b>	380 x 250 x 220	338	240	GTH 48	9000
<b>56.20 01 03</b>	500 x 350 x 150	458	340	GTH 48	11000
<b>56.20 01 04</b>	500 x 350 x 220	458	340	GTH 48	11500
<b>56.20 01 05</b>	500 x 450 x 150	458	440	GTH 48	12000
<b>56.20 01 06</b>	500 x 450 x 220	458	440	GTH 48	12500

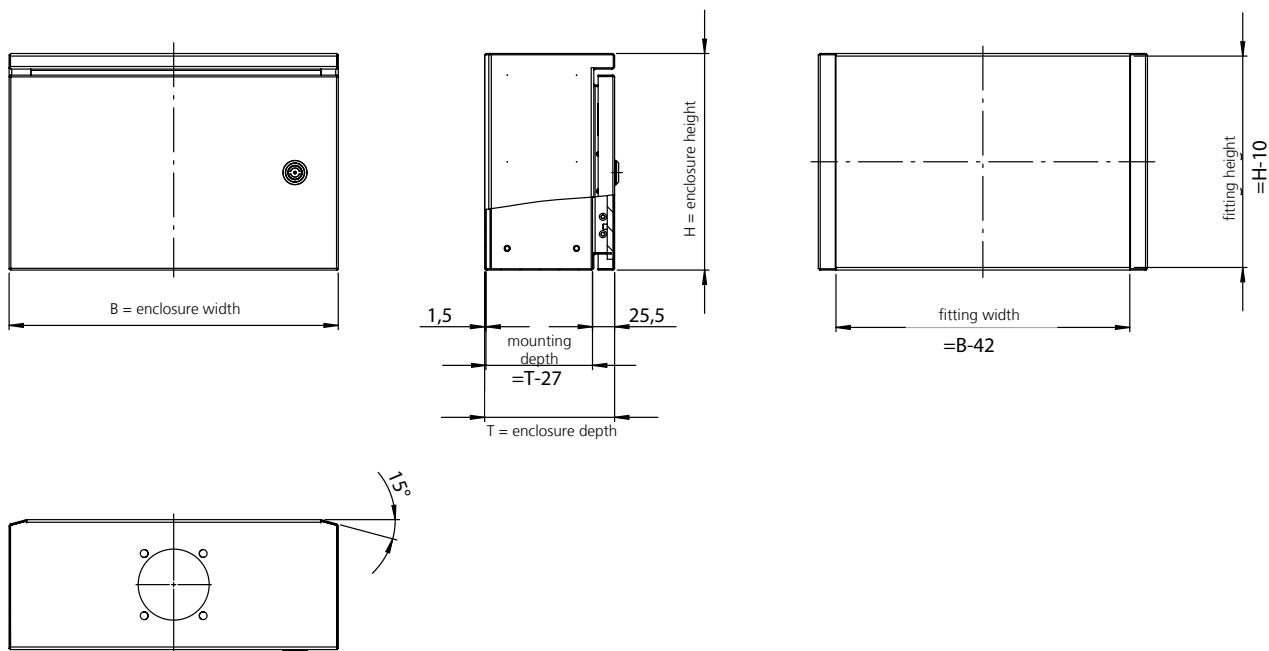

## Accessories

### Mounting bracket set

Order No.	Execution
<b>56.20 99 01</b>	for internal fitting of components

### Handle set



Order No.	Execution
<b>56.20 01 93</b>	Handle set ECO for Commander 420, L = 220 mm
<b>56.20 01 94</b>	Handle set ECO for Commander 420, L = 320 mm
<b>56.20 01 95</b>	Handle set ECO for Commander 420, L = 420 mm



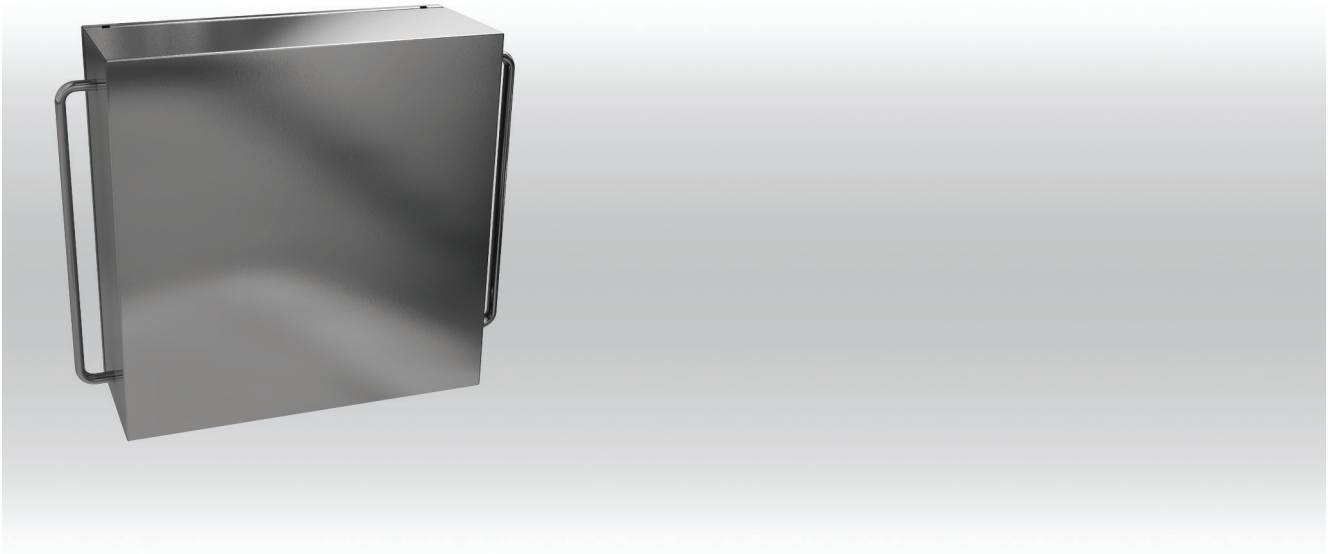

- + Control enclosure in stainless steel 1.4301 (304)
- + Different handle design versions
- + High protection class IP 66
- + Integrated grounding lugs
- + Customized laser processing possible
- + Optional further locking systems made of different materials available (e.g. plastic or zinc die-cast)

**Included in delivery**

Enclosure including reinforcing plate, couplings hole and handles.

**Technical data**

<b>Material</b>	Stainless steel 1.4301/304
<b>Surface</b>	grinded, grain 320
<b>Seal</b>	Silicone
<b>Ingress protection</b>	IP 66
<b>Temperature range</b>	-20 °C to +80 °C

# Commander 450

## Product range

Order No.	Dimensions (mm) W x H x D	Fitting (mm) W x H	Variation	Weight (kg)
56.45 01 01	400 x 300 x 120	300 x 200	with two edge handles (side C/D)	4.21
56.45 01 02	400 x 300 x 120	300 x 200	with two bow handles (side C/D)	5.68
56.45 01 03	400 x 300 x 120	300 x 200	with one bow handle (side B)	5.40
56.45 02 01	400 x 300 x 160	300 x 200	with two edge handles (side C/D)	4.90
56.45 02 02	400 x 300 x 160	300 x 200	with two bow handles (side C/D)	6.37
56.45 02 03	400 x 300 x 160	300 x 200	with one bow handle (side B)	6.09
56.45 03 01	400 x 400 x 160	300 x 300	with two edge handles (side C/D)	7.13
56.45 03 02	400 x 400 x 160	300 x 300	with two bow handles (side C/D)	7.84
56.45 03 03	400 x 400 x 160	300 x 300	with one bow handle (side B)	7.24
56.45 04 01	500 x 300 x 200	400 x 200	with two edge handles (side C/D)	7.49
56.45 04 02	500 x 300 x 200	400 x 200	with two bow handles (side C/D)	8.38
56.45 04 03	500 x 300 x 200	400 x 200	with one bow handle (side B)	8.26
56.45 05 01	500 x 500 x 200	400 x 400	with two edge handles (side C/D)	9.00
56.45 05 02	500 x 500 x 200	400 x 400	with two bow handles (side C/D)	12.00
56.45 05 03	500 x 500 x 200	400 x 400	with one bow handle (side B)	11.00

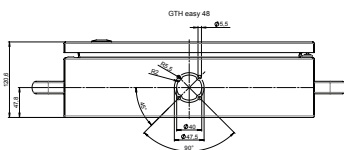
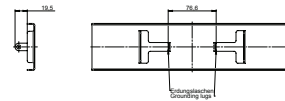
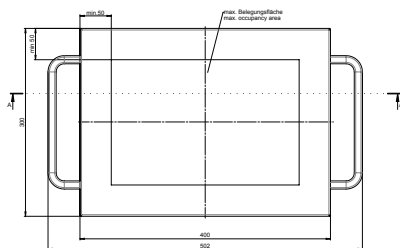
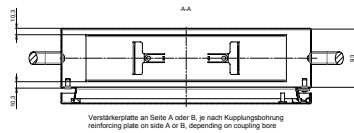

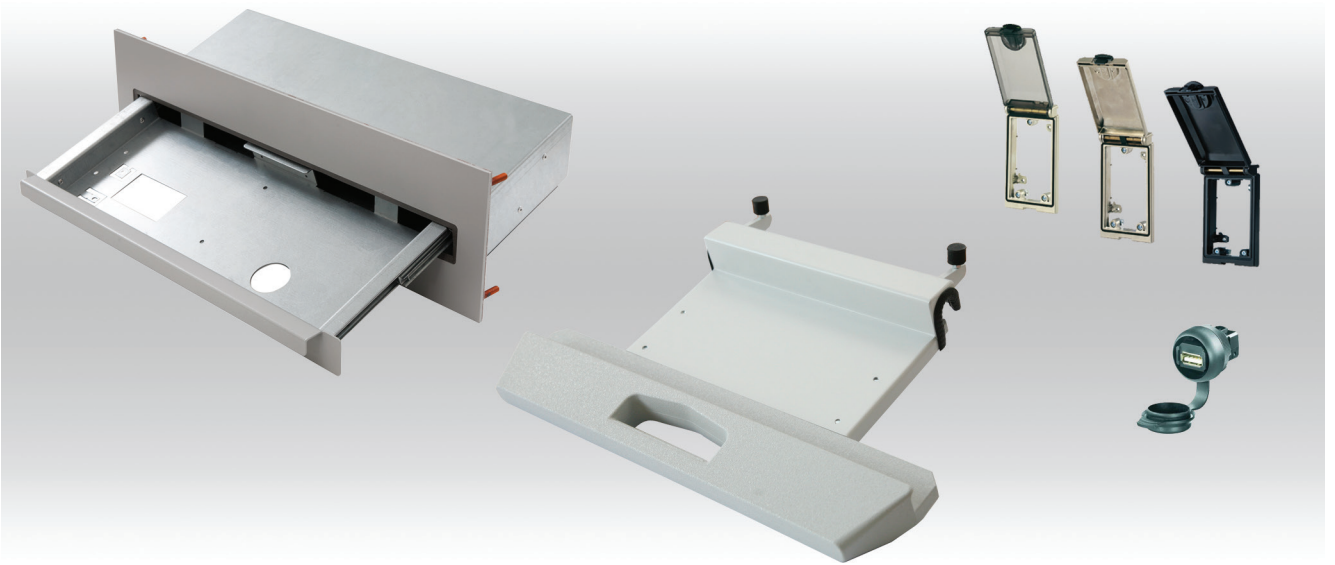

- + Keyboard drawer and keyboard tray
  - + Keyboard holder
  - + Single and multi interface flaps and flap inserts
- 
-

# Commander system accessories

## Keyboard drawer



Order No.	Execution
<b>10.99 20 01</b>	Drawer for keyboards, IP 40 to front side

Installation into command systems:  
 SL 2000, Profile 3  
 SL 3000, Profile 3 and 4  
 SL 4000 Profile 3  
 optional with keyboard

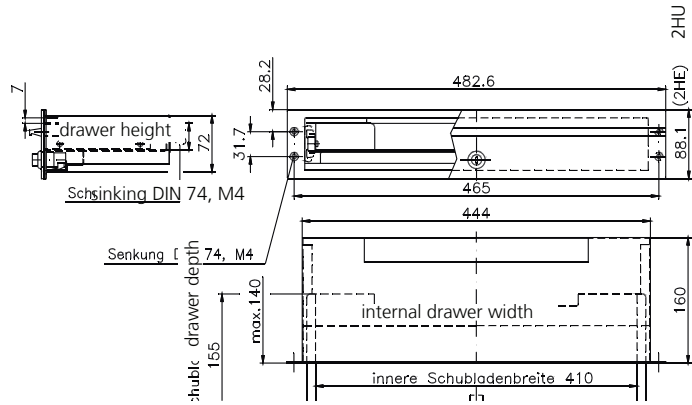

## Mousepad rack



Order No.	Execution
<b>10.99 20 02</b>	for keyboard drawer 10.99 20 01

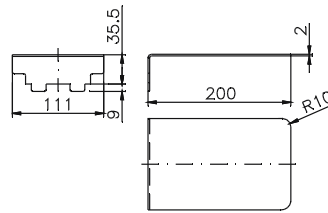

## Keyboard drawer RTS3 with 20° inclination



Order No.	Execution
<b>10.99 20 03</b>	Keyboard drawer RTS3-F (inclination 20° with front plate)
<b>10.99 20 04</b>	Keyboard drawer RTS3 (inclination 20° with front plate)

Built-in drawer for keyboards,  
 IP 65 for the front side  
 Dimensions: 483 x 132.5 x 150 mm  
 for keyboards with maximum dimensions 340 x 170 x 20 mm  
 Drawer with 20° slope with magnetic latch  
 for installing from the front with front panel  
 (RAL 9006, white aluminium) or for installing  
 from the inside of the enclosure  
 Related keyboard on request

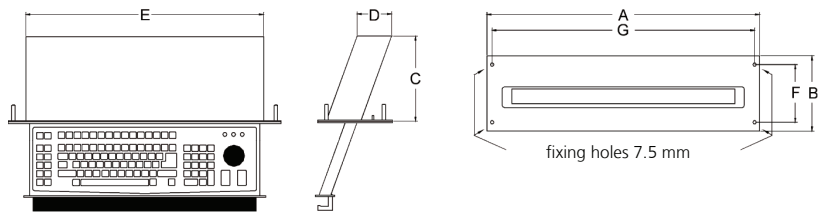

Dimensions (mm)							
A	B	C	D	E	F	G	
483	132,5	150	61	421	101,5	465	



## Keyboard drawer RTS 1 (1 HE)



Built-in drawer for keyboards,  
IP 65 for the front side  
Dimensions: 483 x 44 x 160 mm  
for keyboards with maximum  
dimensions 370 x 140 x 20 mm  
Drawer without slope with  
magnetic latch for installing from  
the front with front panel (RAL  
9006, white aluminium)

Suitable keyboard Cherry  
G84-4400LUBDE

Order No.	Execution
10.99 20 11	with front plate

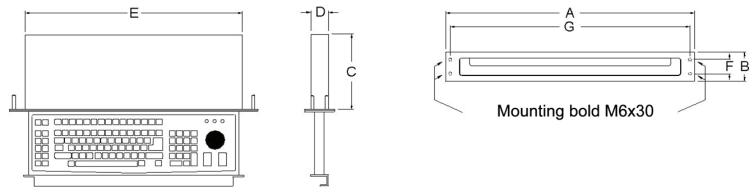

Dimensions (mm)

A	B	C	D	E	F	G
483	44	160	35	421	25	465

## Keyboard drawer RTS 2 (2 HE)

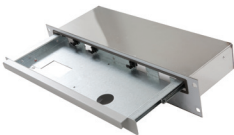

Built-in drawer for keyboards,  
IP 65 for the front side  
Dimensions: 483 x 88 x 150 mm  
for keyboards with maximum  
dimensions 370 x 140 x 20 mm  
Drawer without slope with magnetic  
latch for installing from the front  
with front panel (RAL 9006, white  
aluminium) or for installing from the  
inside of the enclosure  
Related keyboard on request

Order No.	Execution
10.99 20 13	with front plate

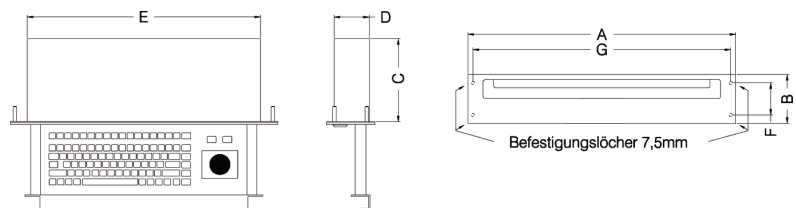

Dimensions (mm)

A	B	C	D	E	F	G
483	88	150	64	421	58	465

## Keyboard drawer RTS4



Built-in drawer for keyboards,  
IP 65 for the front side  
Dimensions: 560 x 123 x 203 mm  
for keyboards with maximum dimensions 465  
x 170 x 25 mm  
Drawer with magnetic latch  
Mouse pad tray can be extended to the right  
or left  
for installing from the front with front panel  
(RAL 7035, light grey)  
incl. mouse Cherry M5450 and integrated  
USB port

suitable keyboard Cherry G-85-23100  
DE-2 (German) or Cherry G-85-23100 EU  
(English) on request

Order No.	Execution
45.80 10 00	with front plate

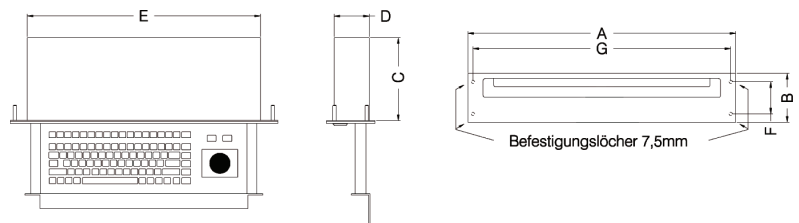

Dimensions (mm)

A	B	C	D	E	F	G
560	123	203	86	512	103	543

# Commander system accessories

## Keyboard tray, sheet steel, inclination 15°



Order No.      Execution

**10.99 20 06**      For mounting between suspension system GTN II and GTS onto commander from bottom side (side B)

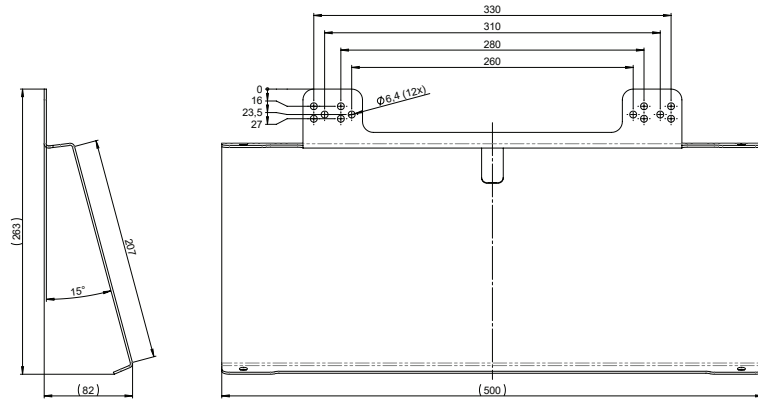

## Mousepad rack, for keyboard tray 10.99 20 xx



Order No.      Execution

**10.99 20 07**      for side mounting onto keyboard tray (right side or left side)

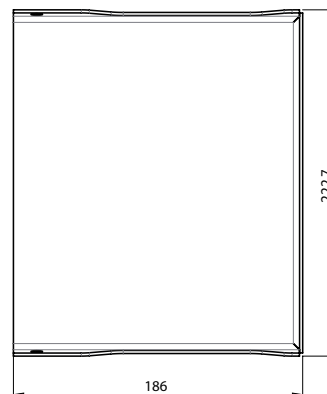

## Keyboard holder for SL 2000



Mounting onto SL 2000 with front panel width  $\geq 370$  mm. With combination onto suspension system at Side B, please note profile depth and swivel range.

Order No.      Execution

**19.60 10 04**      For standard PC keyboards, consisting of mounting elements and keyboard holder

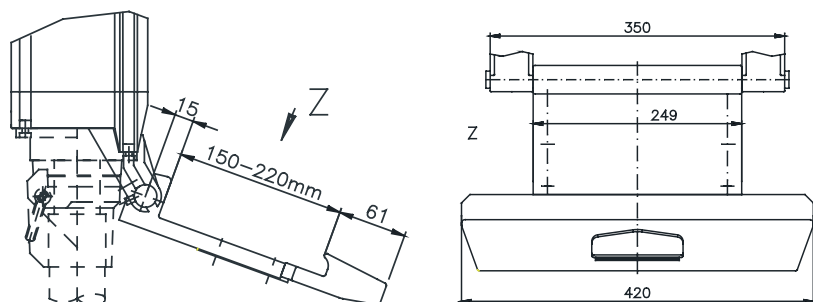

## Keyboard holder SL 4000



Mounting onto SL 4000 profile 2 and profile 3; profile 1 only side A (front plate width > 400 mm); keyboard optionally

Order No.	Execution
<b>20.10 90 20</b>	for standard PC keyboards

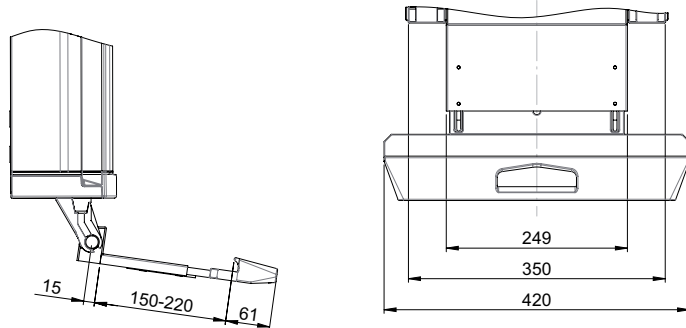

## Keyboard holder SL 3000

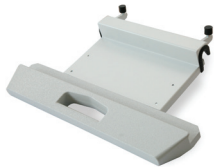

Mounting onto SL 3000;  
Note: only possible with handle mounting on side B

Order No.	Execution
<b>20.10 90 21</b>	for standard PC keyboards

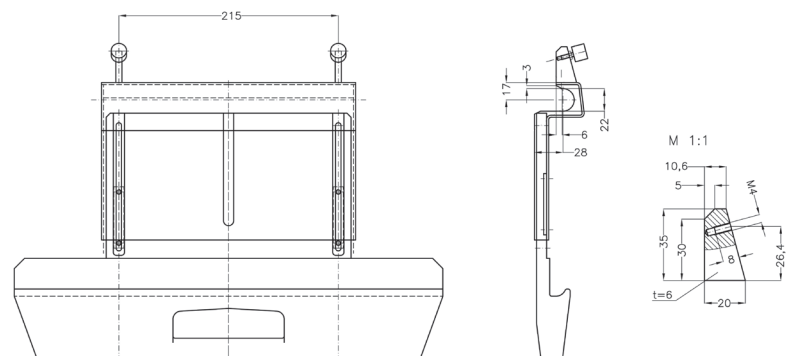

## Mousepad support for keyboard holder



Order No.	Execution
<b>20.10 90 22</b>	for side mounting onto keyboard holder 19.60 10 04, 20.10 90 20 and 20.10 90 21

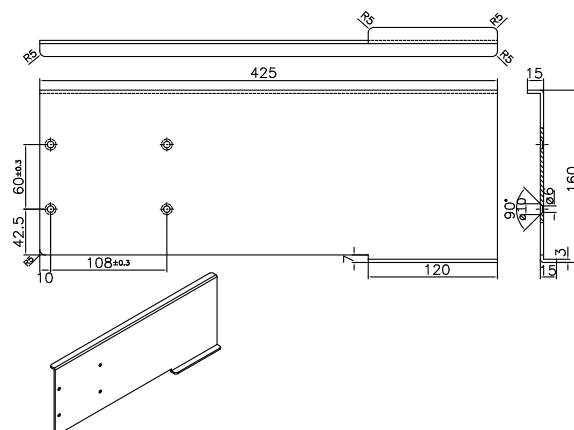



# Commander system accessories

## Document holder



Order No.	Execution
<b>20.60 10 05</b>	Clipboard for side mounting for Commander systems SL 2000, SL 3000, SL 4000, Comtronic onto side
<b>20.60 10 04</b>	Clipboard for fixing onto tube handle at Commander systems

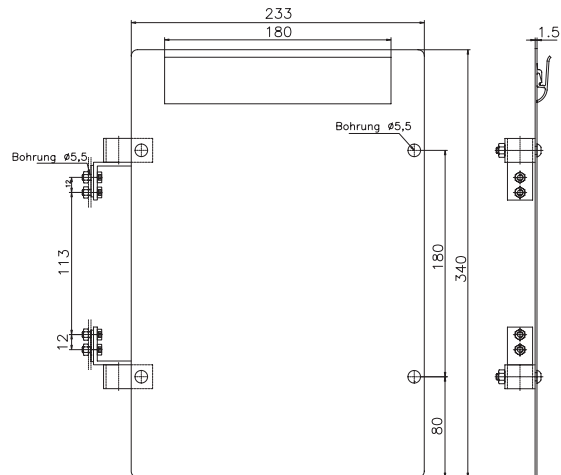

## SL 3000 Mousepad rack

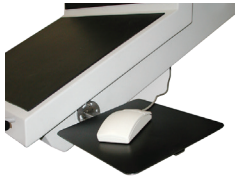

Order No.	Execution
<b>19.60 10 06</b>	For side mounting - colour RAL 9005

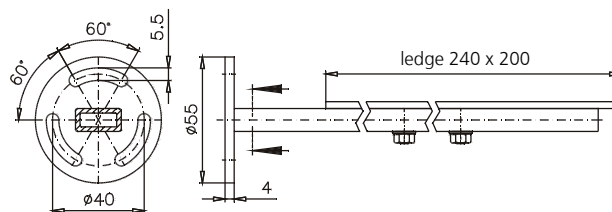

## Fixing plates



for mounting components in Commander

Bestell-Nr	Type	Dimensions A
<b>20.10 91 01</b>	for SL 4000 profile 2	97
<b>20.10 91 02</b>	for SL 4000 profile 3	157
<b>20.10 91 03</b>	for SL 4000 profile 4	96,3
<b>20.10 91 99</b>	individual length	

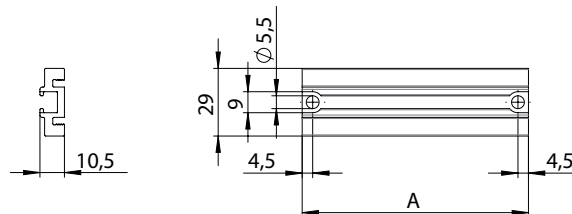

## Grounding plate Commander



Order No.	Execution
<b>20.99 00 01</b>	for installation in Commander SL 4000 (profile 1 and 4)

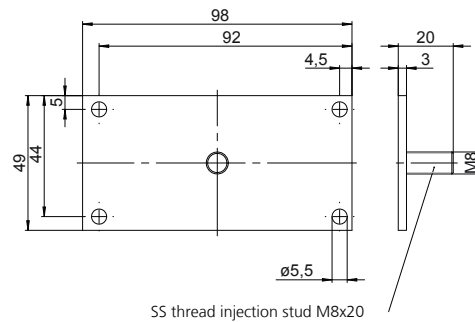

## Wall holder set



Order No.	Execution
<b>20.80 90 01</b>	for Comtronic
<b>20.10 90 30</b>	for SL 3000 and SL 4000 profile 2 , 3 and 4

## Hinge set



for directly mounting onto wall or machine.  
2 hinge incl. screws, colour black

Order No.	Execution
19.60 10 08	for Commander system SL 2000
20.10 90 50	for Commander system SL 4000 profile 1 and 2
20.10 90 60	for Commander system SL 4000 profile 3

# Commander system accessories

## Inclining system



Continuously variable inclining system (+/- 75°) for Commander systems.  
System consisting of aluminium elements with bellow.  
Scope of supply: base unit without adaptation plate

Order No.

**50.02 01 01**

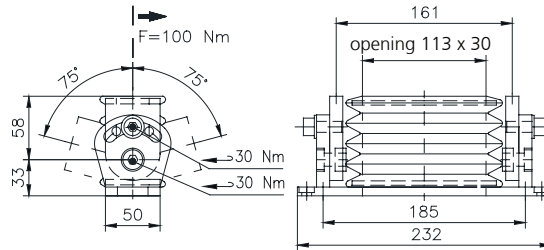

## Adapter plate



for connection of inclining system with Commander systems



Order No.

Execution

<b>50.01 02 03</b>	Adapter plate SL 2000 profile 1
<b>50.01 02 04</b>	Adapter plate SL 2000 profile 2
<b>50.01 02 05</b>	Adapter plate SL 2000 profile 3
<b>50.01 02 06</b>	Adapter plate SL 3000 profile 1
<b>50.01 02 07</b>	Adapter plate SL 3000 profile 2 to 4
<b>50.01 02 08</b>	Adapter plate SL 3000 console version
<b>50.01 02 09</b>	Adapter plate universal (s. drawing)
<b>50.01 02 10</b>	Beckhoff CP 7032 adapter plate
<b>50.01 02 11</b>	ComTronic adapter plate
<b>50.01 02 12</b>	Adapter plate SL 3000 profile 4 (direct mounting)
<b>50.01 02 13</b>	Flat panel adapter
<b>50.01 02 14</b>	Adapter plate SL 4000 profile 1 - 3
<b>50.01 02 15</b>	Adapter plate SL 4000 console version

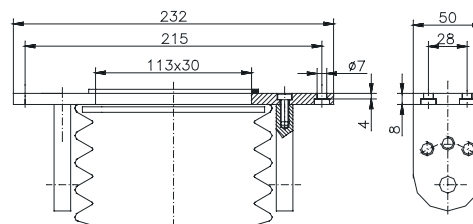

## Single interfaces (IP 65) incl. connection cable and plug



Mounting on profile, front plate  
or rear wall

Order No.	Execution
<b>20.90 10 01</b>	USB-Interface with cable 0,6 m and 1 connector
<b>20.90 10 02</b>	RJ45-Interface with 1 connector
<b>20.90 11 03</b>	USB-Interface without cable
<b>20.90 11 04</b>	RJ45-Interface without cable

## Single interface flaps, metal



For data interfaces and electrical socket.  
Profile 1/2/3: Rear wall or frontplate  
Profile 2/3/4: Sidewise onto profile (Side C/D)

Order No.	Execution
<b>20.90 10 10</b>	Version 1 Frame: Metal, dim nickel plated Lid: Plastic, transparent
<b>20.90 10 11</b>	Version 2 Frame: Metal, dim nickel plated Lid: Metal, dim nickel plated
<b>20.90 10 12</b>	Version 3 Frame: Metal, black Lid: Metal, black

## Single interface flaps, plastic



For data interfaces and electrical socket.  
Profile 1/2/3: Rear wall or frontplate  
Profile 2/3/4: Sidewise onto profile (Side C/D)

Order No.	Execution
<b>20.90 10 14</b>	Version 7 Frame: Plastic, black Lid: Plastic, transparent Lock: 3 mm double ward
<b>20.90 10 15</b>	Version 4 Frame: Plastic, schwarz Lid: Plastic, transparent Lock: Knob
<b>20.90 10 16</b>	Version 8 Frame: Plastic, black Lid: Plastic, metallic silver Lock: 3 mm double ward
<b>20.90 10 17</b>	Version 5 Frame: Plastic, black Lid: Plastic, metallic silver Lock: Knob
<b>20.90 10 18</b>	Version 9 Frame: Plastic, black Lid: Plastic, light grey Lock: 3 mm double ward
<b>20.90 10 19</b>	Version 6 Frame: Plastic, black Lid: Plastic, light grey Lock: Knob

## Commander system accessories

### Double interface flaps, metal



For data interfaces and electrical socket.  
 Profil 1/2/3: Rear wall or front panel  
 Profil 2/3/4: sidewise onto profile (Side C/D)

Order No.	Execution
<b>20.90 11 10</b>	Version 11 Frame: Metal, dim nickel plated Lid: Plastic transparent
<b>20.90 11 11</b>	Version 12 Frame: Metal, dim nickel plated Lid: Metal, dim nickel plated
<b>20.90 11 12</b>	Version 13 Frame: Metal, black Lid: Metal, black

### Double interface flaps, plastic



For data interfaces and electrical socket.  
 Profil 1/2/3: Rear wall oder front panel  
 Profil 2/3/4: Sidewise onto profile (Side C/D)

Order No.	Execution
<b>20.90 11 14</b>	Version 17 Frame: Plastic, black Lid: Plastic, transparent Lock: 3 mm double ward
<b>20.90 11 15</b>	Version 14 Frame: Plastic, black Lid: Plastic, transparent Lock: Knob
<b>20.90 11 16</b>	Version 18 Frame: Plastic, black Lid: Plastic, metallic silver Lock: 3 mm double ward
<b>20.90 11 17</b>	Version 15 Frame: Plastic, black Lid: Plastic, metallic silver Lock: Knob
<b>20.90 11 18</b>	Version 9 Frame: Plastic, black Lid: Plastic, light grey Lock: 3 mm double ward
<b>20.90 11 19</b>	Version 6 Frame: Plastic, black Lid: Plastic, light grey Lock: Knob

### Installation components for interface flaps



Order No.	Execution
<b>20.90 11 05</b>	Schuko/FI Germany (VDE) with additional cut-out for earth leakage circuit breaker (can only be used onto double flaps)



## Data interfaces



**RJ45; USB; SUB-D9; SUB-D9**  
1 × RJ45, 8-pole. Metal, CAT5e (socket/socket)  
1 × USB (socket/socket) Type A  
2 × SUB-D9 (socket/socket)

Order No. **20.90 10 66**



**RJ45; USB; USB (type A)**  
1 × RJ45, 8-pole. metal, CAT5e (socket/socket)  
2 × USB (socket/socket) Type A

Order No. **20.90 10 59**



**RJ45; RJ45**  
2 × RJ45, 8-pole. Metal, CAT5e (socket/socket)

Order No. **20.90 10 69**



**RJ45**  
1 × RJ45, 8-pole. Metal, CAT5e (socket/socket)  
1 × blank cover for SUB-D9

Order No. **20.90 10 70**



**RJ45; RJ45; RJ45; RJ45**  
4 × RJ45, 8-pole. Metal, CAT5e (socket/socket)

Order No. **20.90 10 71**



**USB (type A); RJ45**  
1 × USB (socket/socket) Type A  
1 × RJ45, 8-pole. metal, CAT5e (socket/socket)

Order No. **20.90 10 72**



**1 × RJ45**  
8-pole. metal, CAT5e (socket/socket)  
1 × USB (socket/socket) Type A  
1 × SUB-D9 (socket/pin)

Order No. **20.90 10 74**



**RJ45; USB (type A); SUB-D9**  
1 × RJ45, 8-pole. metal, CAT5e (socket/socket)  
1 × USB (socket/socket) Type A  
1 × SUB-D9 (socket/socket)

Order No. **20.90 10 75**



**USB (type A); USB (type A)**  
2 × USB (socket/socket) Type A

Order No. **20.90 10 86**



**USB; USB; USB; USB (type A)**  
4 × USB (socket/socket) Type A

Order No. **20.90 10 88**



**RJ45; USB; USB (type A)**  
1 × RJ45, 8-pole. Metal, CAT5e (socket/socket)  
2 × USB (socket/socket)/0.7 m Kabel) Type A

Order No. **20.90 10 89**



**USB (type A); RJ45**  
1 × USB (Buchse/Buchse/0.7 m Kabel) Type A  
1 × RJ45, 8-pole. metal, CAT5e (socket/socket)

Order No. **20.90 10 95**

# Commander system accessories

## Flap insert: Plug insert



**Germany (VDE)**  
grey, screw clamps, LED (yellow)

Order No. **20.90 10 24**



**France (UTE)**  
screw clamps

Order No. **20.90 10 26**



**Italy (CEI 23-16)**  
with electric shock protection,  
screw clamps

Order No. **20.90 10 28**



**USA (NEMA 5-15)**  
screw clamps

Order No. **20.90 10 20**



**UK (BS)**  
with electric shock protection,  
screw clamps

Order No. **20.90 10 25**



**China (CCC)**  
with electric shock protection,  
screw clamps

Order No. **20.90 10 22**



**Denmark**  
spring clamps

Order No. **20.90 10 23**



**Switzerland**  
spring clamps

Order No. **20.90 10 29**



**Australia**  
screw clamps

Order No. **20.90 10 21**



**India (IS 1293)**  
with electric shock protection,  
screw clamps

Order No. **20.90 10 27**



**Germany (VDE)**  
yellow, spring clamps

Order No. **20.90 11 20**



**Germany (VDE)**  
orange, spring clamps

Order No. **20.90 11 21**

## Heat management

---

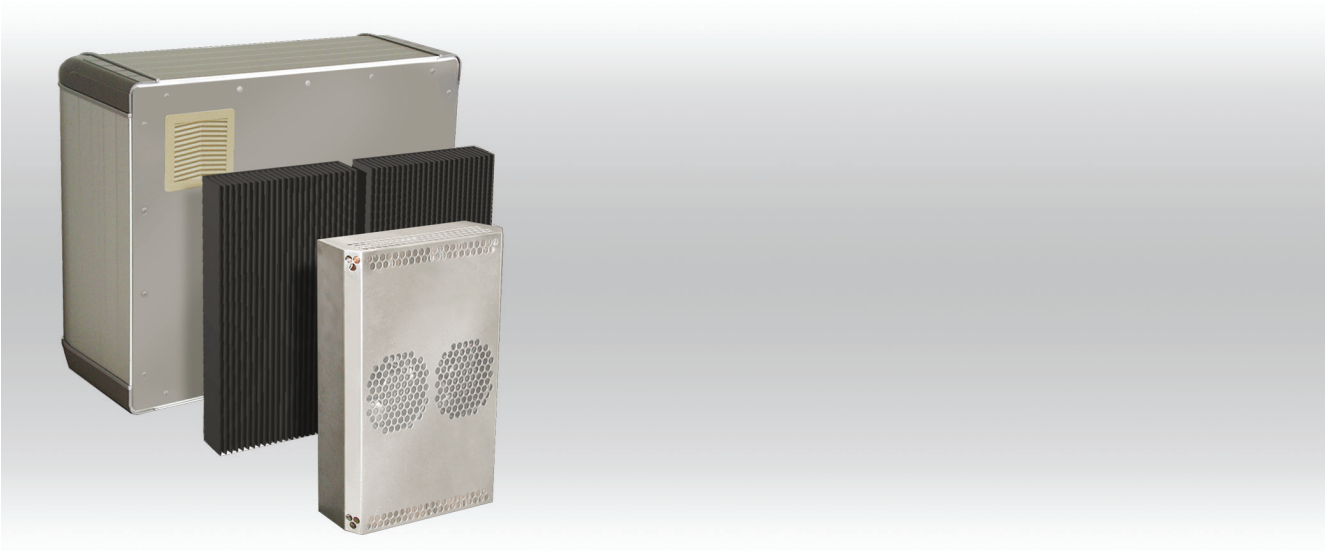

- + Climatic systems for ROSE Commander systems, co-ordinated with the application
- + Filter ventilators upto 25 m<sup>3</sup>/h discharge flow
- + Compressor cooling systems upto 430 W cooling capacity
- + Peltier cooling elements upto 150 W cooling capacity

### **Included in delivery**

Climatic system depending upon execution completely Commander system



Operating and control systems need an enclosure system, which makes an optimal handling possible for the accommodation at the machine in the production process. ROSE offers for this special commander systems. These operating and control systems, usually realized on PC basis, produce a thermal power loss. For the avoidance of the loss of the devices or components and for the securing of the production process air conditioning is necessary. Rose offers here a complete aligned cooling system. With additional heat sinks up to the modern Peltier cooling systems - all options are possible.

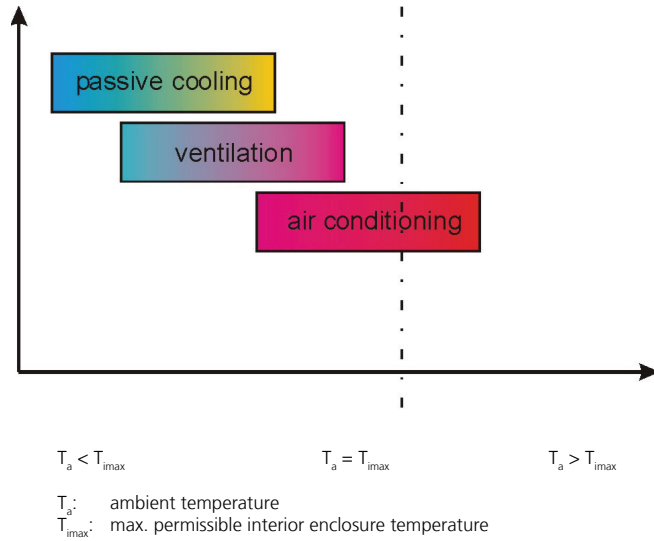

**For all our Commander systems we offer particularly devised cooling systems to you:**

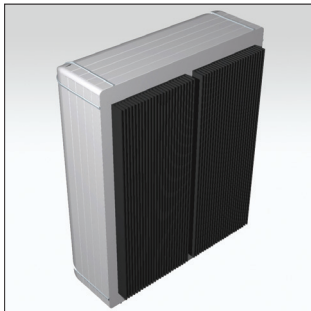

Passive cooling with heat sink rear walls

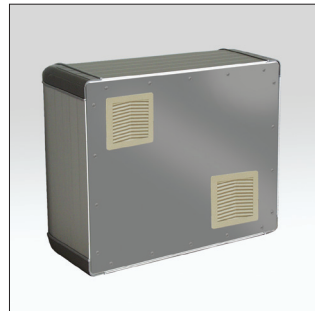

Active cooling with filter ventilator systems



Active cooling with compressor cooling systems

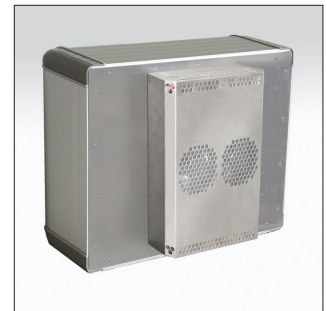

Active cooling with peltier cooling elements



# Heat management

## Filter ventilators with snatching assembly



Order No.	Type	Name	Nominal voltage	Discharge flow
<b>83.10 01 01</b>	RLV 100 230 D	Filter ventilator	230 V AC	25 m³/h
<b>83.10 01 02</b>	RLV 100 24 D	Filter ventilator	24 V DC	25 m³/h
<b>83.10 01 11</b>	RGV 100 D	Exhaust filter		15 m³/h

### Application and function

for the ventilation of cabinets, operating and control enclosures.  
Two versions: for the electrical connection at 24 V DC and to 230 V AC.  
The simple assembly takes place by cutout in door, side wall, rear wall or roof of the enclosure.

### Advantages

Generally high protection classification (IP 54) by fin mounting.  
Short assembly time by simple snatching assembly.  
The ventilator used has UL-, CSA-, VDE- and CE-approvals.

### Technical data

Material	Enclosure: Plastic
Ingress protection	IP 54
Nominal voltage	24 V DC / 230 V AC

RLV 100 230 D / RLV 100 24 D

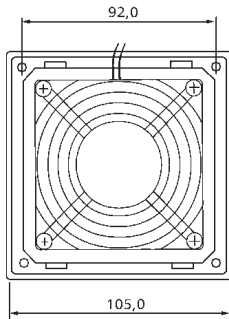

RGV 100 D

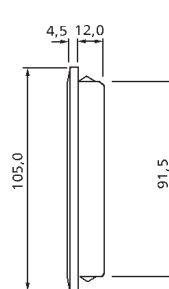
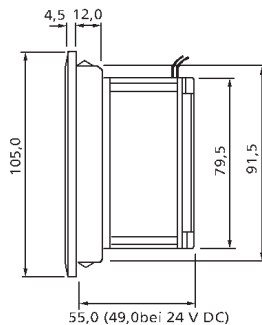

Mounting cutout

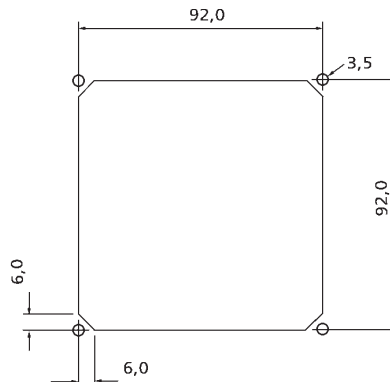
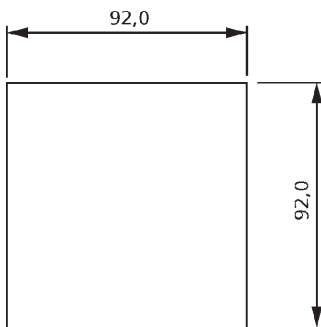

Octagonal cutout and drillings only by screw fastener

## Mini cooling systems in Peltier technology



Order No.	Type	Cooling capacity	Nominal voltage	Nominal current	Weight (g)
<b>83.10 03 01</b>	RPK 50	50 W	24 V DC	2,5 A	3900
<b>83.10 03 02</b>	RPK 100	100 W	24 V DC	4,8 A	7200
<b>83.10 03 03</b>	RPK 150	150 W	24 V DC	6,5 A	7300

### Application and function:

for the active cooling of cabinets, operating and control enclosures, industrial PC's, monitor and flat screen monitor.

3 types in 50, 100 and 150 W cooling capacity are available.

For the electrical connection at 24 V DC. The simple assembly takes place by cutout in door, side wall, rear wall or roof of the enclosure.

### Advantages of

Peltier cooling units:

- compact design
- assembly in each position, because the units work without refrigerants
- high efficiency

### The Peltier effect

The Peltier effect is a thermoelectrical procedure, where a semiconductor material is used which is caused with appropriate doting by current guidance the change of the energy state by charge carriers and thus used to the transport of heat.

### Technical data

Operating temperature	-10 °C to +60 °C
Nominal current	24 V +6%/-10%
Ingress protection inside/outside	IP 54

### Computation of the necessary cooling performance:

$$P_k = P_v - k \times A \times T$$

$P_k$  = Necessary cooling performance (W)

$P_v$  = Dissipation loss of built in devices (W)

$k \times A \times T$  = Inner convection of device

$k$  = Thermal transmission coefficient (eg: sheet metal = 5.5 W / m<sup>2</sup> K)

$A$  = Usable enclosure area (m<sup>2</sup>)

$\Delta T = T_i - T_a$  = Temperature difference between inner and surrounding temperature

# Heat management

## RPK 50

### Diagram

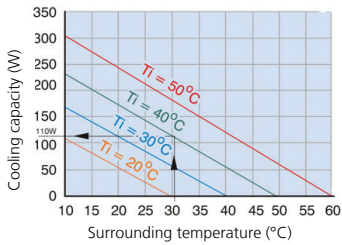

Chose:  $P_K = 6 \text{ W/K} \times \Delta T + 50 \text{ W}$   
 Example:  $T_a = 30^\circ\text{C}$ ,  $T_i = 40^\circ\text{C}$  d.h.:  $P_K = 110 \text{ W}$

### Dimensions

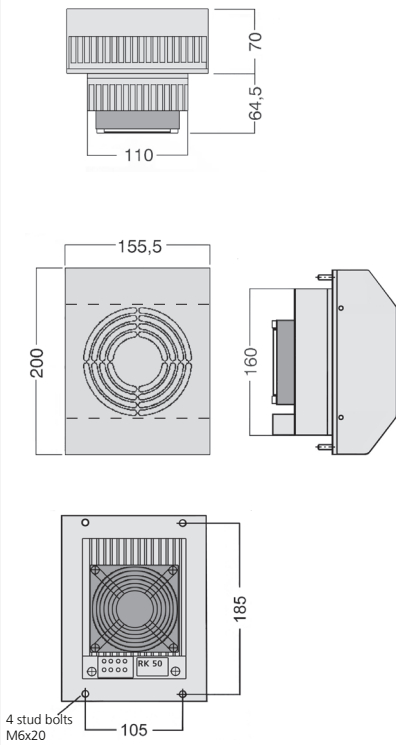

### Mounting cutout

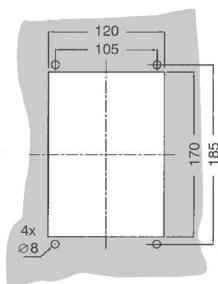

## RPK 100

### Diagram

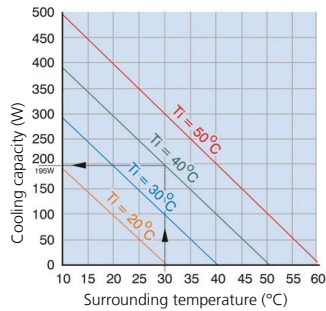

Chose:  $P_K = 9,5 \text{ W/K} \times \Delta T + 100 \text{ W}$   
 Example:  $T_a = 30^\circ\text{C}$ ,  $T_i = 40^\circ\text{C}$  d.h.:  $P_K = 195 \text{ W}$

### Dimensions

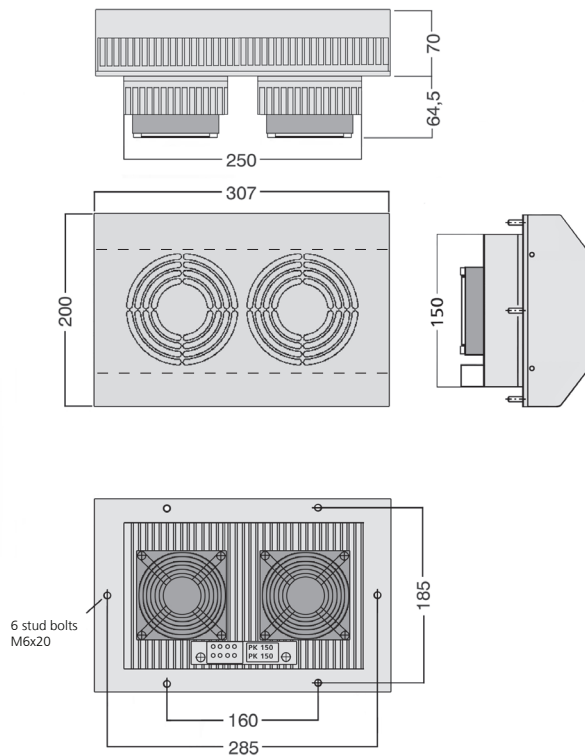

### Mounting cutout

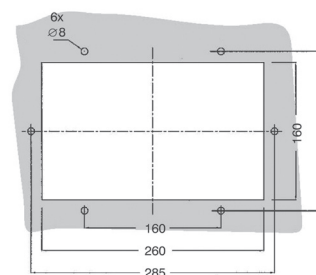

## RPK 150

### Diagram

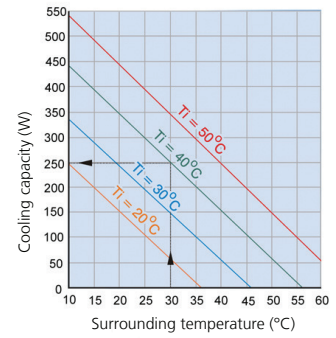

Chose:  $P_K = 9,5 \text{ W/K} \times \Delta T + 150 \text{ W}$   
 Example:  $T_a = 30^\circ\text{C}$ ,  $T_i = 40^\circ\text{C}$  d.h.:  $P_K = 245 \text{ W}$

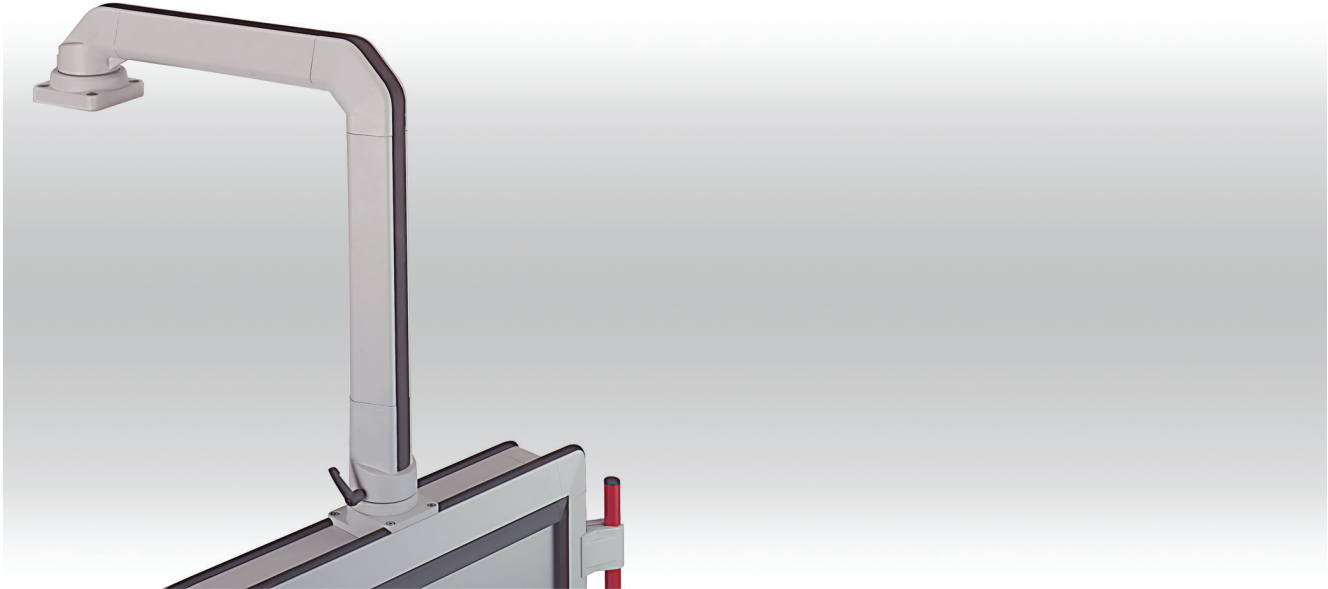

- + Industrial suspension system for control enclosures
- + Modular construction with free accessible cable channel
- + Wall, top-mounting or floor fixing

**Included in delivery**

Individual system components incl. cable channel covering and assembly materials

**Technical data**

<b>Material</b>	Connecting tube: DIN EN 573 EN AW-ALMgSi Components: DIN EN 1706 EN AC-AISI 12 (Fe) Cover profile: TPE
<b>Painting</b>	Powder coating
<b>Colour</b>	Tube and components in RAL 7035, lightgrey Cover profile: RAL 9005, jet black
<b>Ingress protection</b>	IP 54 to EN 60529



## Product range

Type	Order No.	Weight (g)
Top-mounted joint	<b>49.45 66 00</b>	1430
Foot stand	<b>49.45 72 00</b>	538
Wall hinge W	<b>49.45 70 00</b>	2250
Angle	<b>49.45 71 00</b>	533
Coupling	<b>49.45 73 00</b>	521
Coupling GTKe-PRO	<b>49.45 73 02</b>	1010
Flange coupling	<b>49.45 77 00</b>	957
Angle coupling	<b>49.45 75 00</b>	882
Angle coupling GTKe-PRO	<b>49.45 75 02</b>	1270
Flange angle coupling	<b>49.45 78 00</b>	1017
Spare cover profile 2.5 m	<b>49.45 69 00</b>	206
Adapter plate GTKe-PRO	<b>49.45 00 01</b>	175

### Aluminium profile, max. outreach 1.5 m

Connecting tube	Order No.	Weight (g)
Standard length: 0,5 m	<b>49.45 10 01</b>	1625
Standard length: 1 m	<b>49.45 10 02</b>	3250
Standard length: 2 m*	<b>49.45 10 03</b>	6500
Variable length (please specify)		

without threaded hole

### Adaptation capability, using elements from GT 48/2 range\*

	Order No.	Weight (g)
Console flange 30°	<b>49.49 76 00</b>	400
Adapter flange	<b>49.49 79 00</b>	1500
Inclination adapter	<b>49.49 80 00</b>	800

\* Special colour RAL 7035 please specify when ordering.

## Load diagram

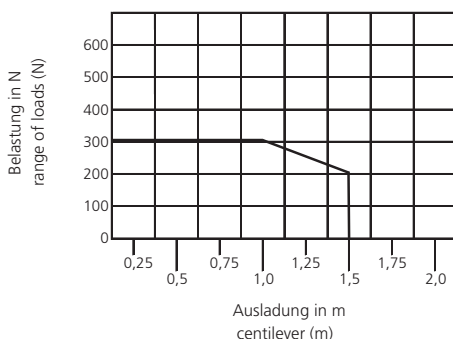

Note: the vertical length of the profile is responsible for the load of the complete suspension system (lever arm!). Further information for this on request. The values in the above load diagram are guilty to an execution on hanging or standing. The declarations of weight are a summary from

- installation weight,
- Commander weight
- and all components and tubes between Commander and angle.

### System structure

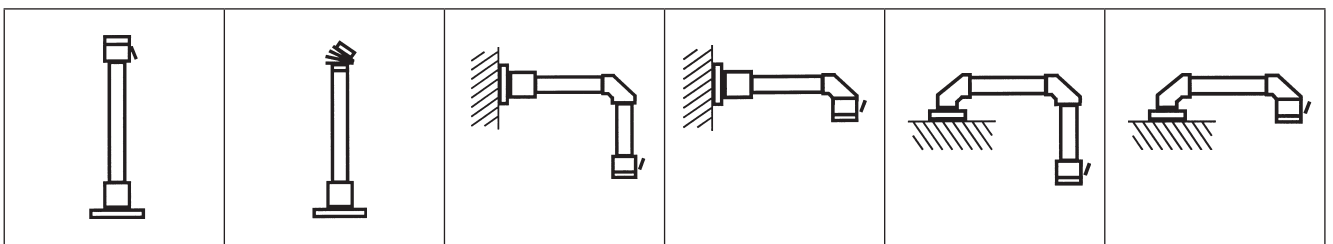

Components

Top-mounted joint



Order No.	Execution
<b>49.45 66 00</b>	Cast aluminium with steel inner tube and flange mounting. Swivelling range 330° (cannot be limited or stopped)

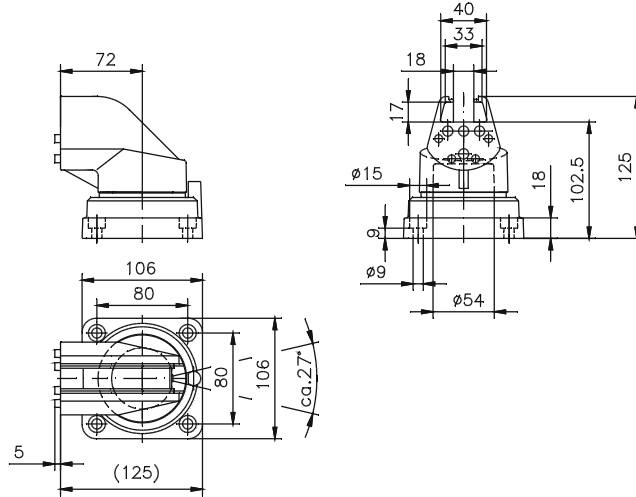

Wall hinge



Order No.	Execution
<b>49.45 70 00</b>	Cast aluminium with steel inner tube and plain bearing Swivelling range 330° (cannot be limited or stopped)

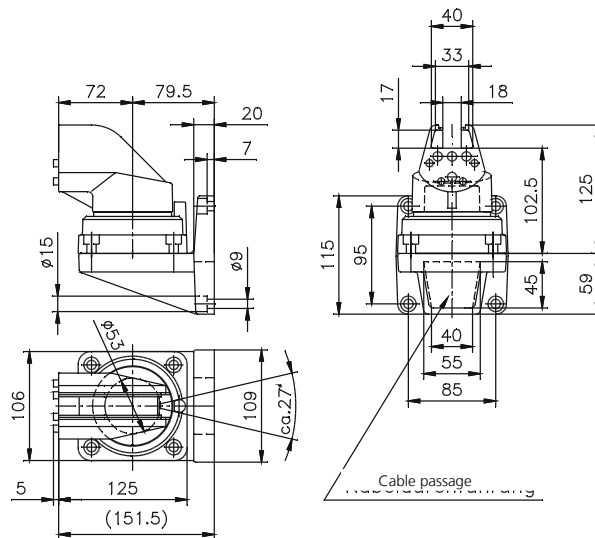

Angle



Order No.	Execution
<b>49.45 71 00</b>	Cast aluminium, angle 90°

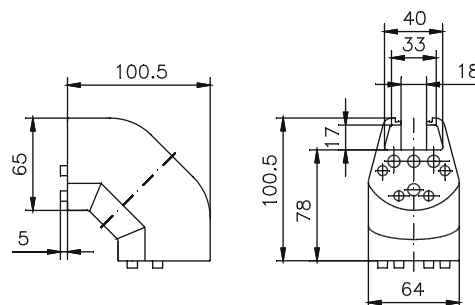

**Components**

Connecting tube



Order No.	Execution
<b>49.45 10 01</b>	0,5 m Aluminium extruded profile incl. plastic cover profile
<b>49.45 10 02</b>	1 m Aluminium extruded profile incl. plastic cover profile
<b>49.45 10 03</b>	2 m Aluminium extruded profile incl. plastic cover profile

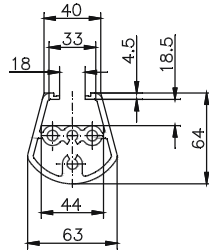

Coupling



Order No.	Execution
<b>49.45 73 00</b>	Cast aluminium with internal steel tube. Swivelling range 290°

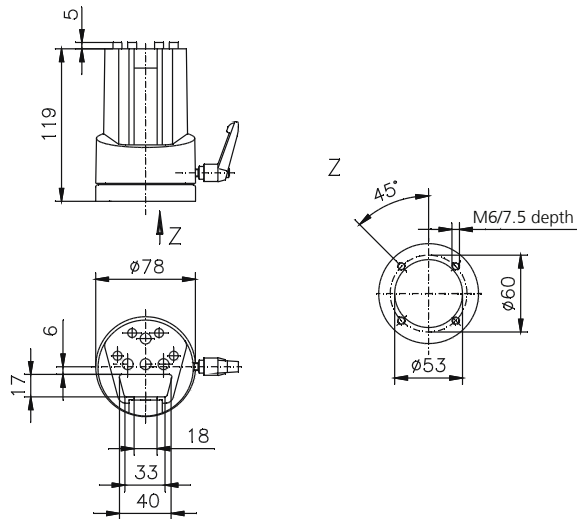

Coupling für Siemens Pro



Order No.	Execution
<b>49.45 73 02</b>	for direct connection to Siemens Pro devices. Swivelling range 290°

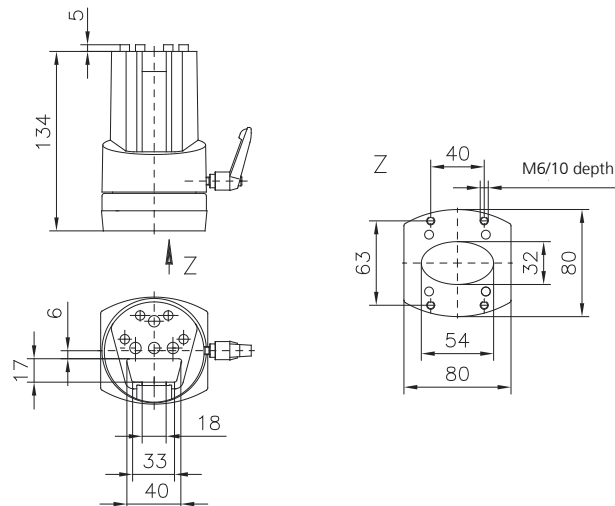



Components

Angle coupling



Order No.

Execution

**49.45 75 00**

Combination of angle and coupling for horizontal tube exit. Cast aluminium with steel inner tube. Swivelling range 290°

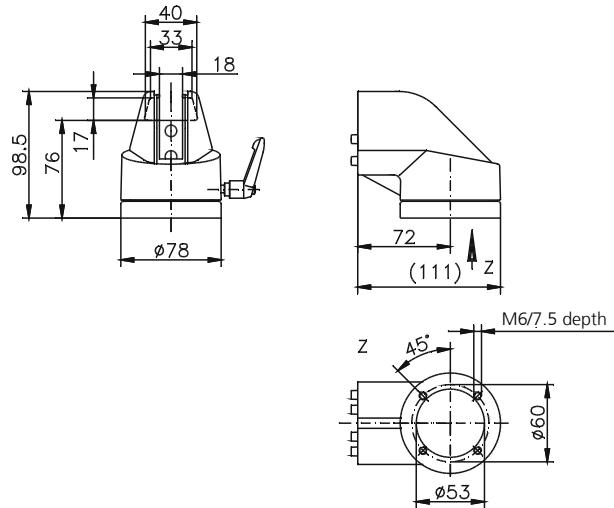

Angle coupling for Siemens Pro



Order No.

Execution

**49.45 75 02**

for direct connection to Siemens Pro commander units  
Combination of angle and coupling for horizontal tube exit. Cast aluminium with steel inner tube. Swivelling range 290°

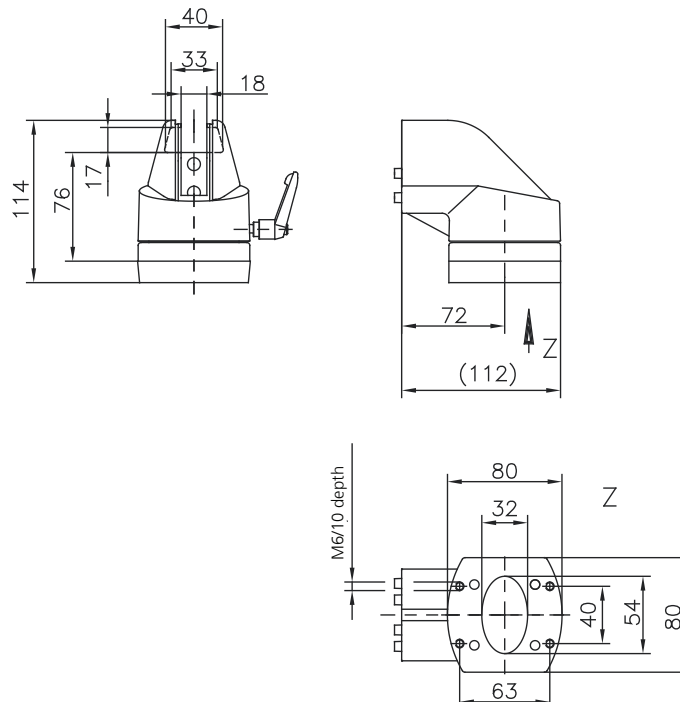

**Components**

Flange coupling



Order No.

Execution

**49.45 77 00**

Cast aluminium with internal steel tube.  
Swivelling range 290°

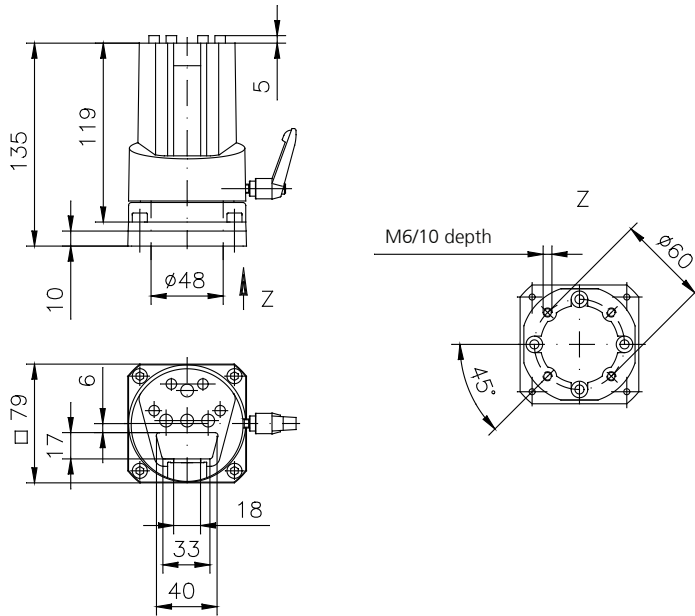

Flange angle coupling



Order No.

Execution

**49.45 78 00**

Combination of angle and coupling for horizontal tube exit. Cast aluminium with internal steel tube.  
Swivelling range 290°

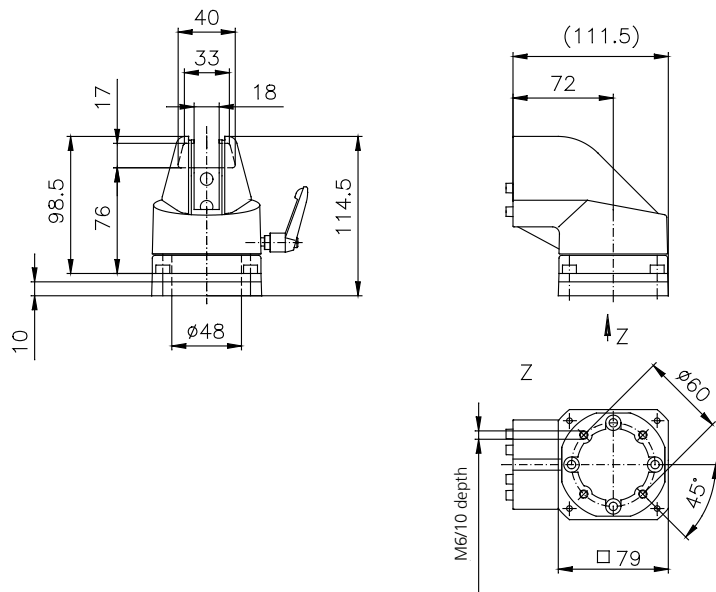

**Components**

Foot stand



Order No.	Execution
<b>49.45 72 00</b>	Cast aluminium, fixed version

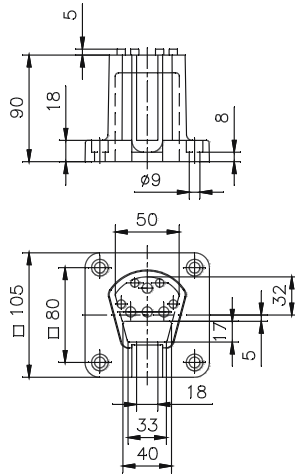

Adapter plate GTKe-Pro



Order No.	Execution
<b>49.45 00 01</b>	Adapter plate for connecting GTK electronic elements with Siemens Pro-command units (not necessary for coupling GTKe Pro and angle coupling GTKe Pro)

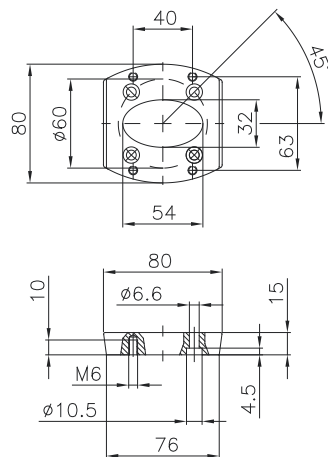



- + Aluminium profile suspension system for light/medium loads up to 30 kg
- + Product family GTS / GTN / GTL
- + Can be combined with all Commander systems
- + Standardly adjustable solution for individual loads

### Included in delivery

System individual components incl. cable duct cover and assembly material.

## Technical data

<b>Material</b>	Connecting tube: DIN EN 573 EN AW-AMgSi Components: DIN EN 1706 EN AC-ALSi 12 (Fe)
<b>Painting</b>	Powder coating
<b>Colour</b>	Tube, components: RAL 7035, light grey
<b>Ingress protection</b>	IP 54 to EN 60529

## Product range

Type	Order No.	Weight (g)
Top-mounted joint	<b>49.44 66 00</b>	1560
Foot stand	<b>49.44 72 00</b>	300
Foot stand turnable	<b>49.44 72 21</b>	872
Wall hinge W	<b>49.44 70 00</b>	2400
Wall hinge S	<b>49.44 70 30</b>	1720
Angle	<b>49.44 71 00</b>	783
Angle GTS / GT 48/2	<b>49.44 71 49</b>	1100
Coupling	<b>49.44 73 00</b>	569
Coupling 15°, combination of coupling and console flange 15°	<b>49.44 73 76</b>	891
Flange coupling	<b>49.44 77 00</b>	901
Angle coupling	<b>49.44 75 00</b>	1260
Angle coupling, combination of angle coupling and console flange 15°	<b>49.44 75 76</b>	1550
Inclining adapter	<b>49.44 80 00</b>	950
Coupling Siemens PRO	<b>49.44 73 02</b>	820
Angle coupling Siemens PRO	<b>49.44 75 02</b>	1480
Adapter plate Siemens Pro	<b>49.44 00 01</b>	198
Coupling DN, combination of coupling and inclining adapter	<b>49.44 62 00</b>	1600

Aluminium profile, max. outreach 1.5 m	Order No.	Weight (g)
GTS Profile, painted RAL 7035, 0.5 m	<b>49.44 10 01</b>	1570
GTS Profile, painted RAL 7035, 1 m	<b>49.44 10 02</b>	3110
GTS Profile, painted RAL 7035, 2 m*	<b>49.44 10 03</b>	6210
Variable length (please specify)	<b>49.44 10 99</b>	
Aluminium profile, max. outreach 1.5 m	Order No.	Weight (g)
GTS Profile anodized 0,5 m	<b>49.44 11 01</b>	1570
GTS Profile anodized 1 m	<b>49.44 11 02</b>	3110
GTS Profile anodized 2 m*	<b>49.44 11 03</b>	6210
GTS Profile anodized, variable length (please specify)	<b>49.44 99 99</b>	

\* without threaded hole

## Load diagram

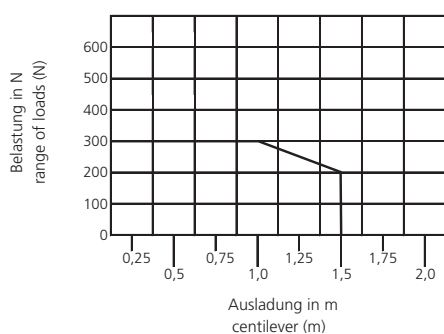

Note: the vertical length of the profile is responsible for the load of the complete suspension system (lever arm!).

Further information for this on request. The values in the above load diagram are guilty to an execution hanging or standing.

The declarations of weight are a summary from installation weight, Commander and all components and tubes between Commander and angle.

## System structure

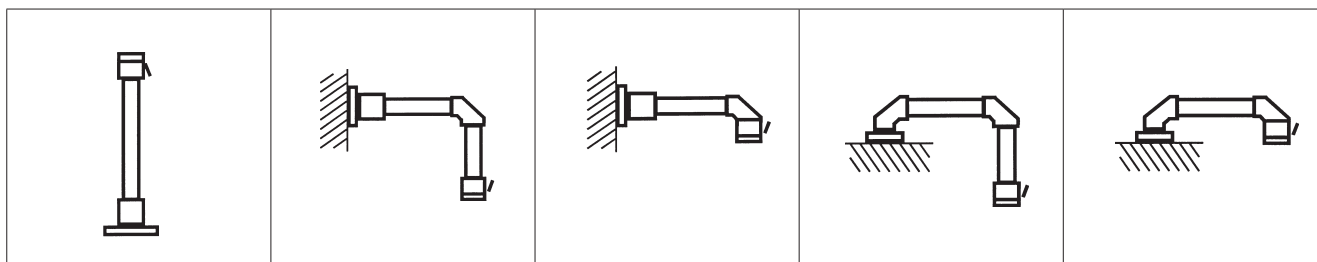

Components

Top-mounted joint



Order No.

Execution

**49.44 66 00**

Cast aluminium with flange mounting. Swivelling range to 330°

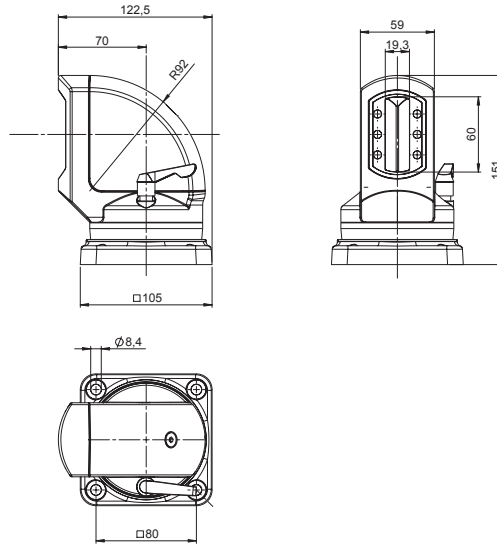

Wall hinge



Order No.

Execution

**49.44 70 00**

Cast aluminium with plain bearing. Lockable via clamping lever. Swivelling range 330°

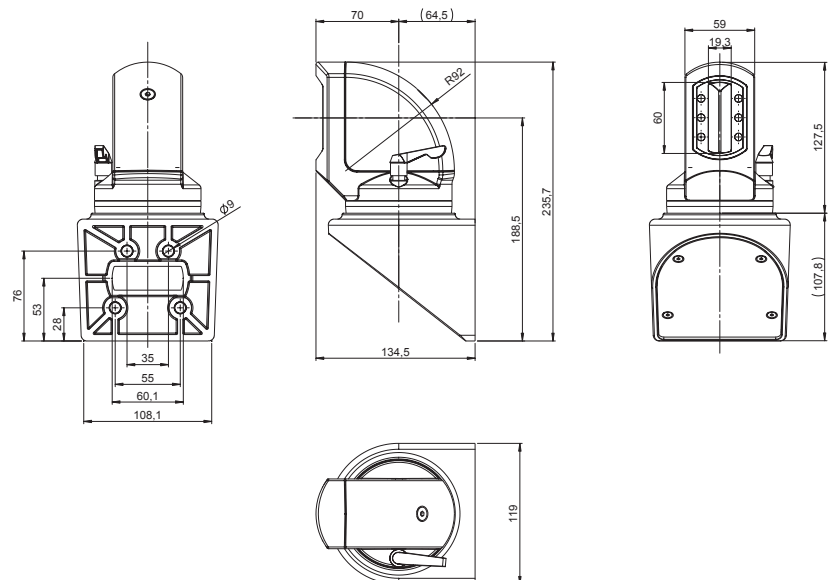

## Components

### Angle



Order No.

Execution

**49.44 71 00**

Cast aluminium, angle 90°, incl. lid

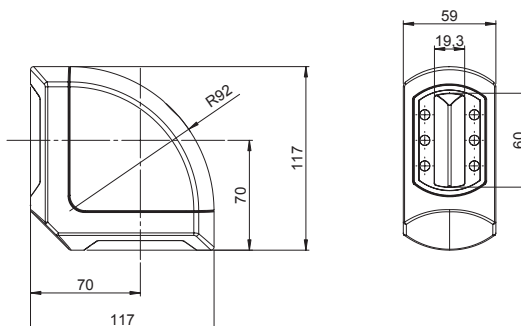

### Angle GTN II / GTS

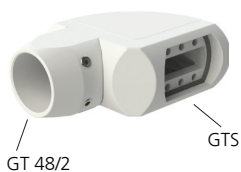

Order No.

Execution

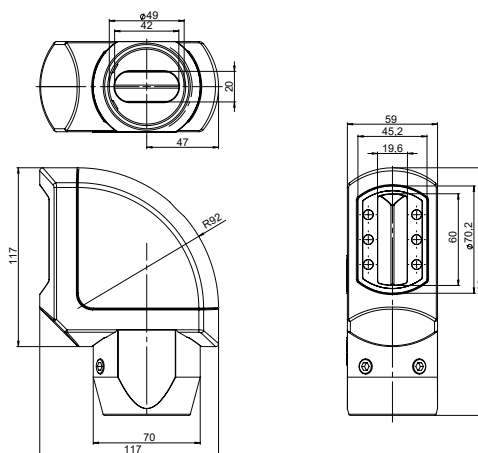
**49.44 71 49**for combination GTS and  $\varnothing 48$  Round tube system

Components

Foot stand

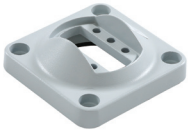

Order No.

Execution

**49.44 72 00**

Cast aluminium, fixed version, for floor mounting or wall mounting with rigid outlet

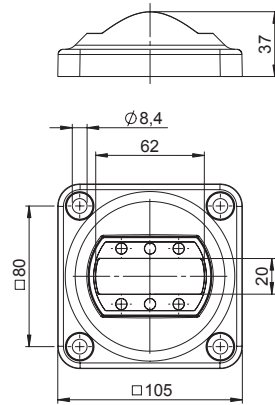

Foot stand turnable



Order No.

Execution

**49.44 72 21**

Cast aluminium with adjustable stop for direct connection onto machine and command unit

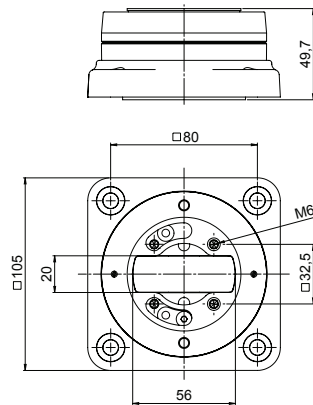



## Components

### Profile, RAL 7035



Order No.	Execution
<b>49.44 10 01</b>	0.5 m Aluminium extrusion profile
<b>49.44 10 02</b>	1 m Aluminium extrusion profile
<b>49.44 10 03</b>	2 m Aluminium extrusion profile
<b>49.44 10 99</b>	Aluminium extrusion profile, variable length (please specify)

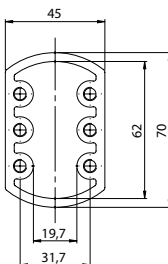

### Profile, anodized



Order No.	Execution
<b>49.44 11 01</b>	0.5 m Cast aluminium extrusion profile
<b>49.44 11 02</b>	1 m Cast aluminium extrusion profile
<b>49.44 11 03</b>	2 m Cast aluminium extrusion profile
<b>49.44 11 99</b>	Cast aluminium extrusion profile, variable length (please specify)

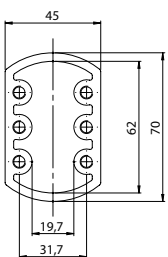

### Coupling



Order No.	Execution
<b>49.44 73 00</b>	Cast aluminium, Swivelling range 330°. Lockable with clamping lever.

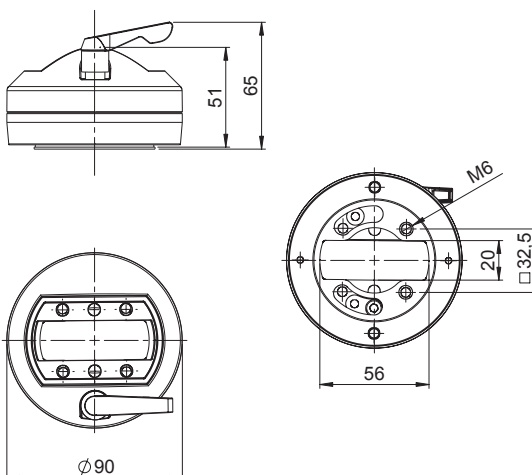

Components

Coupling Siemens Pro



Order No.

Execution

**49.44 73 02**

For direct connecting of Siemens PRO command units. Diecast aluminium, coupling mounting onto Siemens base adaption; Swivelling range 330°. Lockable with clamping lever.

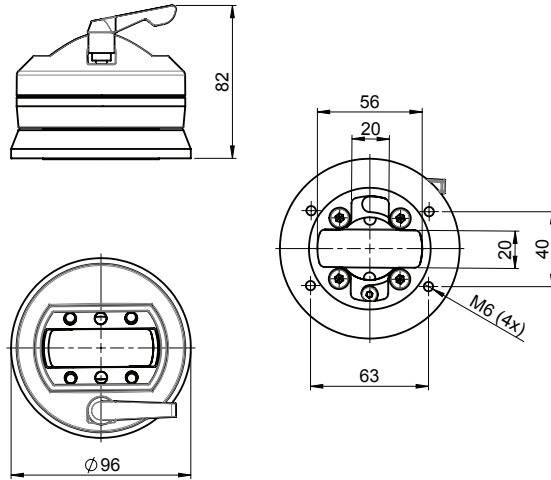

Flange coupling



Order No.

Execution

**49.44 72 00**

Diecast aluminium with adjustable stop position between machine and control panel. Lockable with clamping lever.

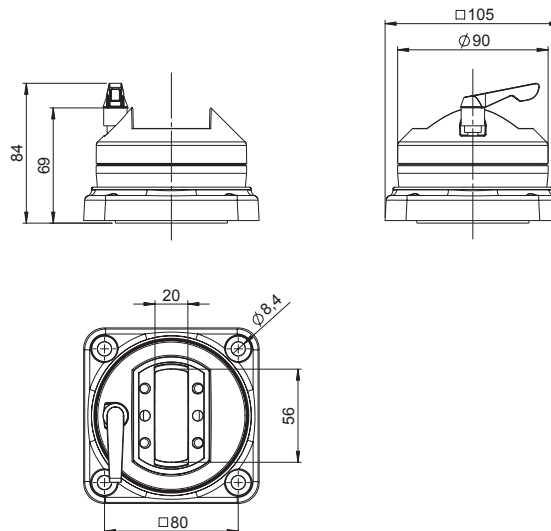

## Components

### Angle coupling



Order No. Execution

**49.44 75 00**

Combination of angle und coupling for horizontal tube exit. Diecast aluminium, Swivelling range 330°. Lockable with clamping lever.

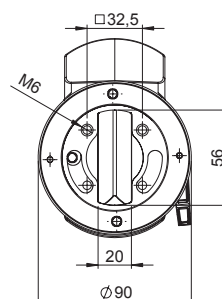
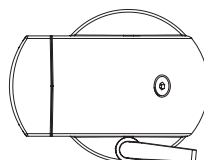
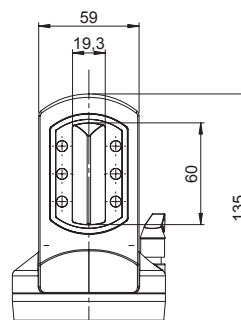
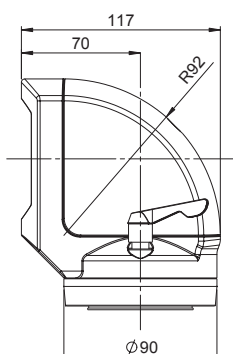

### Angle coupling Siemens Pro



Order No. Execution

**49.44 75 02**

For direct connecting of Siemens PRO command units. Diecast aluminium, coupling mounting onto Siemens baseadaption; Swivelling range 330°. Lockable with clamping lever.

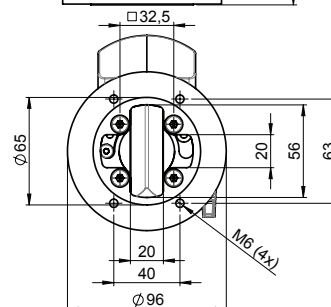
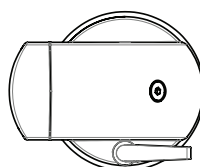
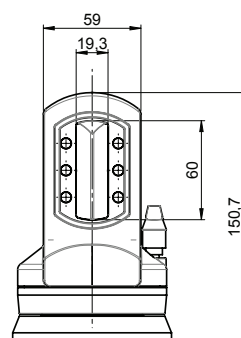
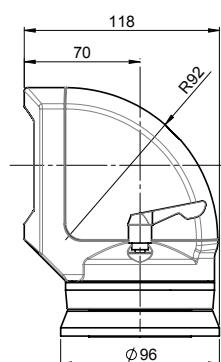

## Components

### Angle coupling, combination of angle coupling and console flange 15°



Order No.	Execution
<b>49.44 75 76</b>	Combination of angle und coupling for horizontal tube exit. Diecast aluminium, Swivelling range 330°, Lockable with clamping lever, including 15° Inclining.

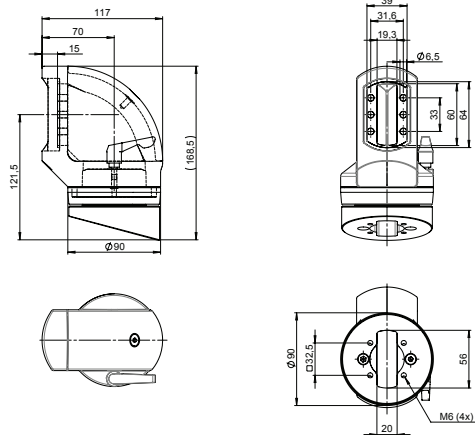

### Adapter plate Siemens Pro



Order No.	Execution
<b>49.44 00 01</b>	For connecting GTS system components (e.g. inclining adapter) with Siemens PRO command units (with GTS coupling Siemens PRO and GTS angle coupling Siemens Pro not necessary)

### Inclining adapter



Order No.	Execution
<b>49.44 80 00</b>	Diecast aluminium element with bellows and gasket. Inclining range from 0° to 45° continuously adjustable. Fixing with screws between enclosure and coupling.

## Components

### Base connection element for suspension systems, command units and cabinets



Order No.      Execution

**49.00 01 01**      Signal light adaptation with thread M20x1.5 mm

**49.00 01 02**      Signal light adaptation with thread M22x1.5 mm

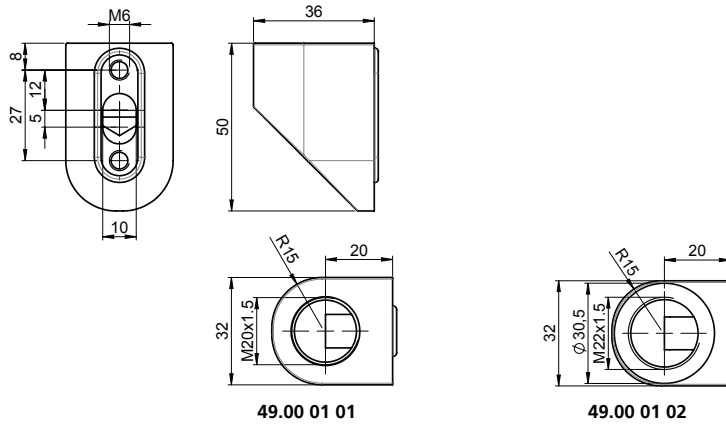

### Base connection element for suspension systems, command units and cabinets



Order No.      Execution

**49.00 01 03**      Signal light adaption with tube  $\varnothing$  25 mm, length = 250 mm

**49.00 01 04**      Signal light adaption with tube  $\varnothing$  25 mm, length = 150 mm

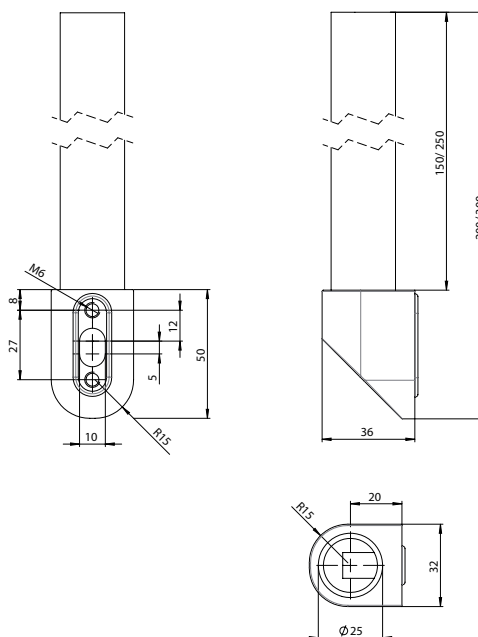



- + Design aluminium suspension system
- + Closed profile system
- + profile with free accessible cable duct
- + Can be combined with all control enclosures
- + Optionally with continuous potential equalization

### Included in delivery

System individual components incl. cable duct cover and assembly material.

## Technical data

<b>Material</b>	Tube: DIN EN 573 EN AW-AlMgSi Components: DIN EN 1706 EN AC-AISI 12 (Fe) Cover profile: TPE
<b>Painting</b>	Powder coating
<b>Colour</b>	Tube, components: RAL 7035, light grey Cover profile: RAL 9005, jet black
<b>Ingress protection</b>	IP 54 to EN 60529

## Product range

Type	Order No.	Weight (g)
Top-mounted joint	<b>49.47 66 00</b>	5300
Top-mounted joint light*	<b>49.47 66 01</b>	5300
Top-mounted joint (ceiling mounting)	<b>49.47 66 20</b>	5300
Wall hinge	<b>49.47 70 00</b>	6150
Wall hinge light*	<b>49.47 70 01</b>	6150
Wall hinge hanging	<b>49.47 70 20</b>	6150
Vertical Wall hinge	<b>49.47 70 30</b>	6060
Angle	<b>49.47 71 00</b>	1130
Angle GTN II / GTK electronic	<b>49.47 71 45</b>	1760
Angle GTN II / GTS	<b>49.47 71 44</b>	1860
Angle GTN II / GT 48/2	<b>49.47 71 49</b>	2030
Coupling	<b>49.47 73 00</b>	1780
Coupling GTN II-PRO	<b>49.47 73 02</b>	2190
Coupling fixed	<b>49.47 73 03</b>	1220
Angle coupling	<b>49.47 75 00</b>	2740
Angle coupling GTN II-PRO	<b>49.47 75 02</b>	3500
Angle coupling	<b>49.47 75 49</b>	5300
Intermediate joint "Z"	<b>49.47 67 00</b>	6520
Intermediate joint "Z" light*	<b>49.47 67 01</b>	6520
Intermediate joint "S"	<b>49.47 67 02</b>	6520
Intermediate joint "S" light*	<b>49.47 67 03</b>	6520
Foot stand fixed	<b>49.47 72 00</b>	1220
Foot stand turnable with adapter plate	<b>49.47 72 20</b>	3630
Foot stand turnable	<b>49.47 72 21</b>	2320
Foot stand turnable with adapter plate light*	<b>49.47 72 22</b>	3590
Console flange 15°	<b>49.47 76 00</b>	708
Column, length max. 2.0 m (please specify individual length)	<b>49.47 00 04</b>	special length
Spare cover profile 2,5 m	<b>49.45 69 00</b>	206
Adjustment set	<b>49.47 00 06</b>	58
Inclining adapter	<b>49.47 80 00</b>	2320
Adapter plate GTN II-PRO	<b>49.47 00 01</b>	469
Height adjustment unit GTN II / GT 48/2	<b>49.47 30 01</b>	
Height adjustment slide hanging	<b>49.47 30 02</b>	14000
Height adjustment slide standing	<b>49.47 30 03</b>	13000

\* light: can be used for control units with low load (up to 30 kg/2 m) with lower swivel force.

Aluminium profile	Profile open	Weight (g)	Profile closed	Weight (g)
Standard length: 0,5 m	<b>49.47 10 01</b>	3060	<b>49.47 20 01</b>	2710
Standard length: 1 m	<b>49.47 10 02</b>	6140	<b>49.47 20 02</b>	5420
Standard length: 2 m	<b>49.47 10 03</b>	12000	<b>49.47 20 03</b>	11000
Variable length (please specify)	<b>49.47 10 99</b>		<b>49.47 20 99</b>	
Profile anodized				
Standard length: 0,5 m	<b>49.47 11 01</b>	3070	<b>49.47 21 01</b>	2710
Standard length: 1 m	<b>49.47 11 02</b>	6140	<b>49.47 21 02</b>	5420
Standard length: 2 m	<b>49.47 11 03</b>	12000	<b>49.47 21 03</b>	11000
Variable length (please specify)	<b>49.47 11 99</b>		<b>49.47 21 99</b>	



# GTN II

## Load diagram

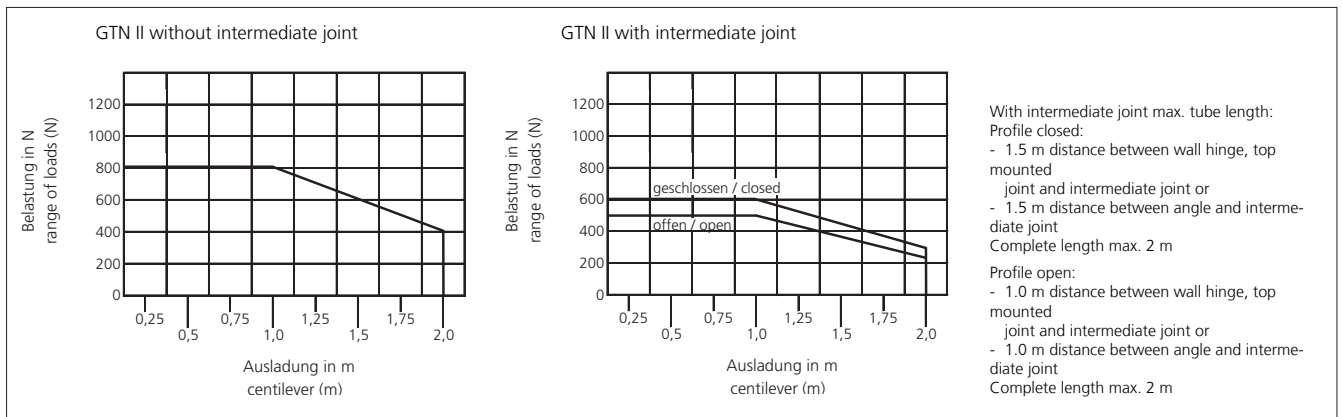

Note: the vertical length of the profile is responsible for the load of the complete suspension system (lever arm!). Further information for this on request. The values in the above load diagram are guilty to an execution hanging or standing. The declarations of weight are a summary from installation weight, Commander and all components and tubes between Commander and angle.

## System structure

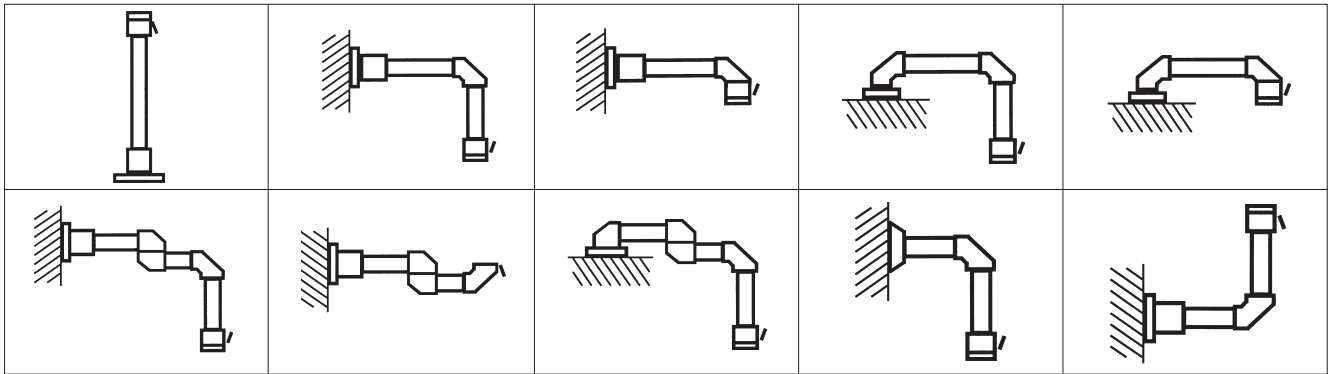

## Komponenten

### Vertical wall hinge



Order No.	Execution
49.47 70 30	GTN II, vertical wall hinge

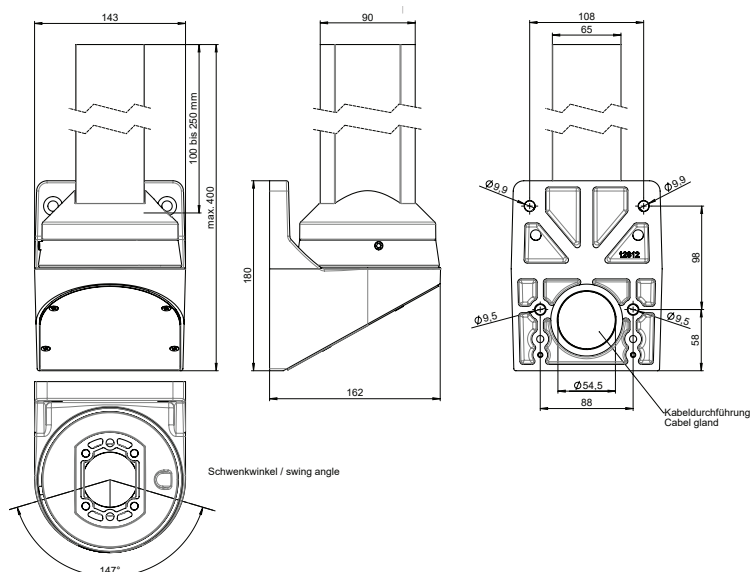



Components

Top-mounted joint



Order No.	Execution
<b>49.47 66 00</b>	GTN II, diecast aluminium, swivelling range 310°. Lockable with adjustment screw.
<b>49.47 66 01</b>	GTN II light, diecast aluminium, swivelling range 310°

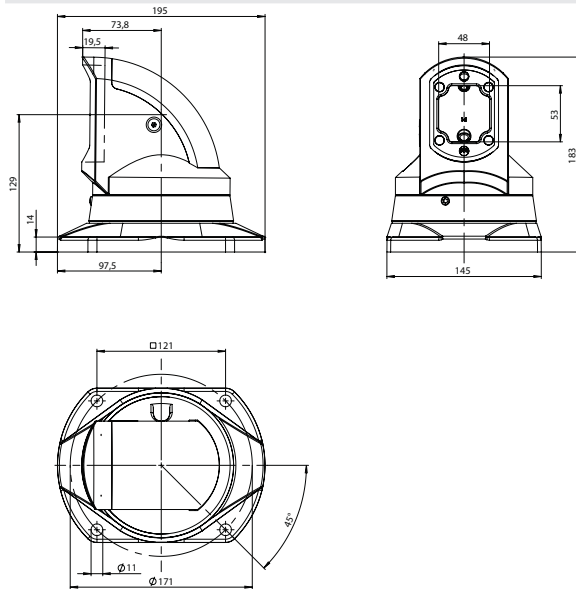

Wall hinge



Order No.	Execution
<b>49.47 70 00</b>	GTN II, diecast aluminium, swivelling range 230°. Lockable with adjustment screw.
<b>49.47 70 01</b>	GTN II light, diecast aluminium, swivelling range 230°. Lockable with adjustment screw.
<b>49.47 70 20</b>	GTN II hanging, diecast aluminium, swivelling range 230°. Lockable with adjustment screw.

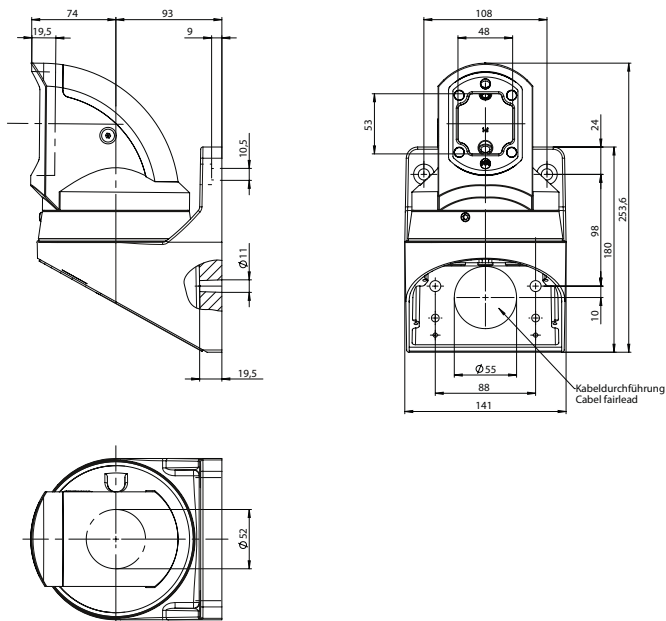

# GTN II

## Components

### Angle



Order No.	Execution
<b>49.47 71 00</b>	Diecast aluminium, angle 90°

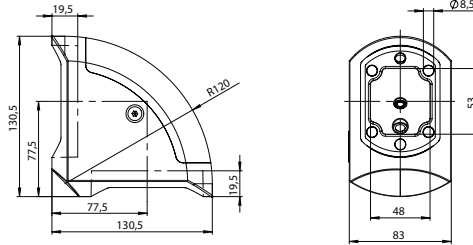

### Angle GTN II / GTK electronic



Order No.	Execution
<b>49.47 71 45</b>	For combination GTN II and GTK electronic

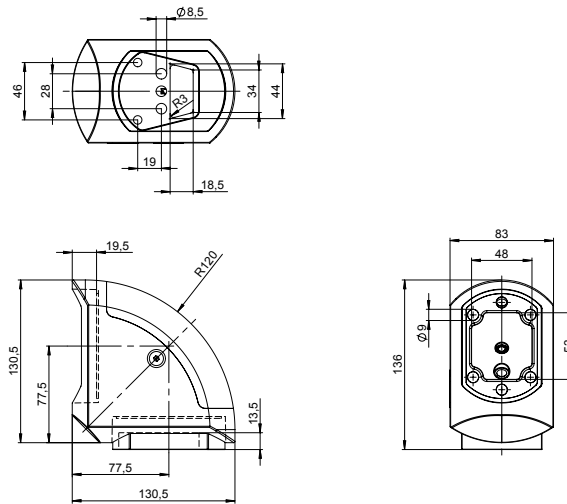

### Angle GTN II / GTS

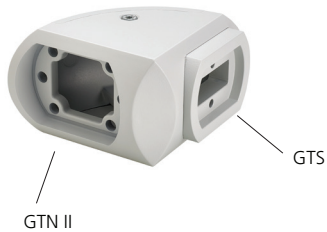

Order No.	Execution
<b>49.47 71 44</b>	For combination GTN II and GTS

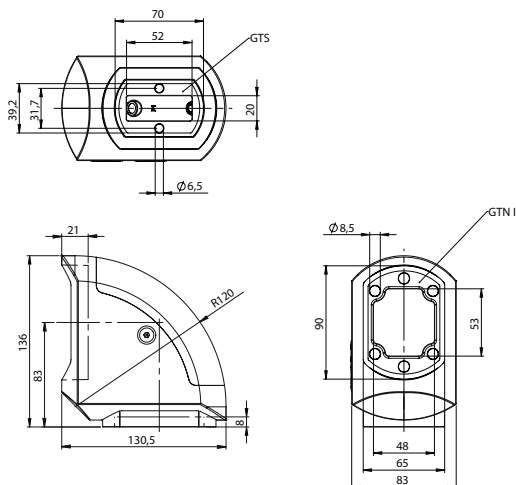

**Components**

**Angle GTN II / GT 48/2**

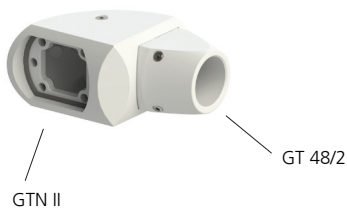

Order No.	Execution
<b>49.47 71 49</b>	For combination GTN II and $\varnothing 48$ mm round tube system

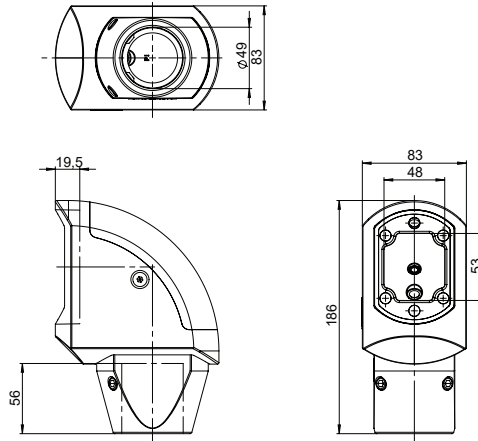

**Coupling**



Order No.	Execution
<b>49.47 73 00</b>	Diecast aluminium, swivelling range 330°. Lockable with clamping lever.

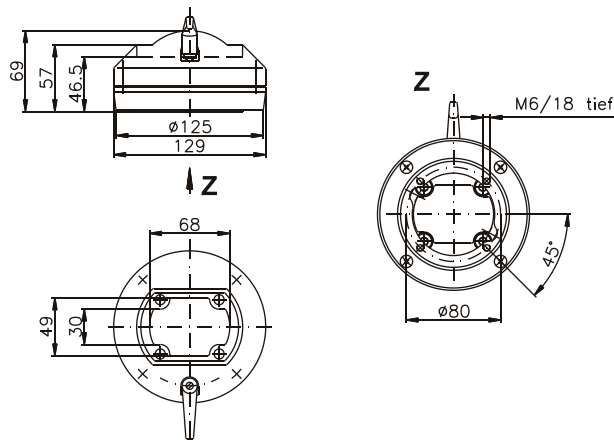

**Coupling fixed**



Order No.	Execution
<b>49.47 73 03</b>	Diecast aluminium, fixed version

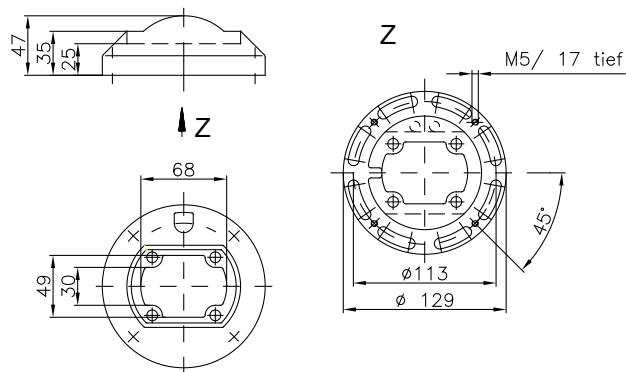

# GTN II

## Components

### Angle coupling



Order No.

Execution

**49.47 75 00**

Diecast aluminium, swivelling range 320°. Lockable with clamping lever.

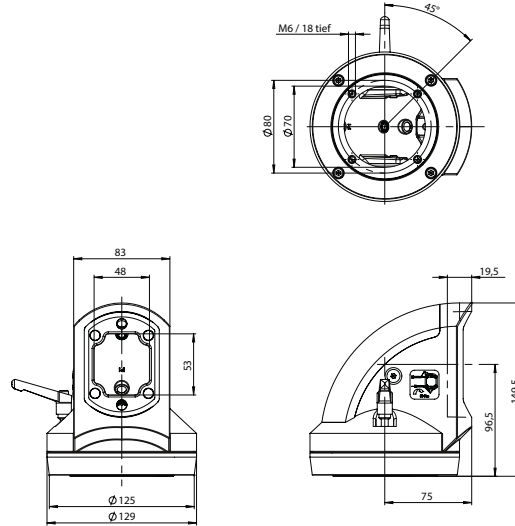

### Coupling GTN II-PRO



Order No.

Execution

**49.47 73 02**

For direct connecting of Siemens Pro command units  
diecast aluminium, swivelling range 330°. Lockable with clamping lever.

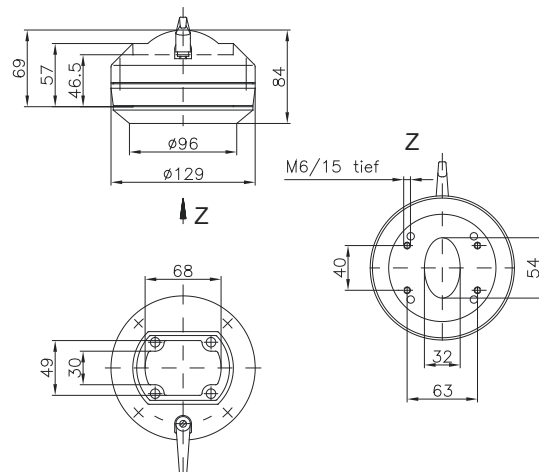

**Components**

**Intermediate joint**



Order No.	Execution
<b>49.47 67 00</b>	GTN II „Z“, diecast aluminium, swivelling range 310°. Lockable with clamping lever.
<b>49.47 67 01</b>	GTN II „Z“ light, diecast aluminium, swivelling range 310°. Lockable with clamping lever.
<b>49.47 67 02</b>	GTN II „S“, diecast aluminium, swivelling range 310°. Lockable with clamping lever.
<b>49.47 67 03</b>	GTN II „S“ light, diecast aluminium, swivelling range 310°. Lockable with clamping lever.

Intermediate joint S-Type

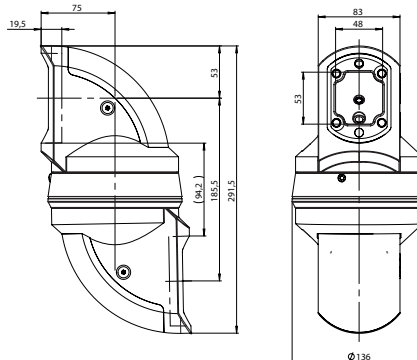
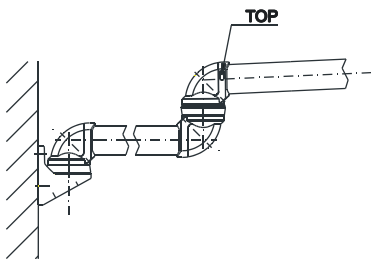

Intermediate joint Z-Type

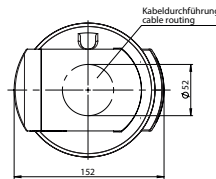
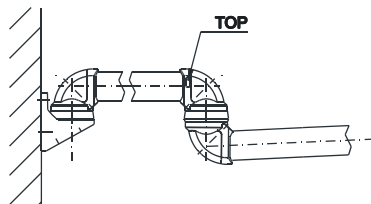

**Angle coupling**



Order No.	Execution
<b>49.47 75 49</b>	GTN II, Angle Coupling GT 48/2

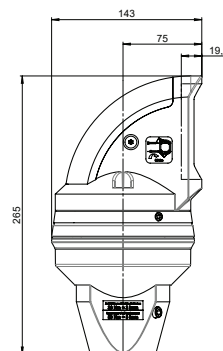
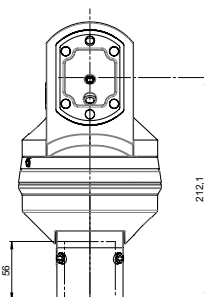
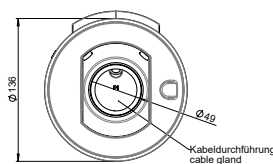

# GTN II

## Components

### Angle coupling GTN II-PRO



Order No.      Execution

**49.47 75 02**      for direct connecting of Siemens Pro command units  
Cast aluminium, Swivelling range 320°. Lockable with clamping lever.

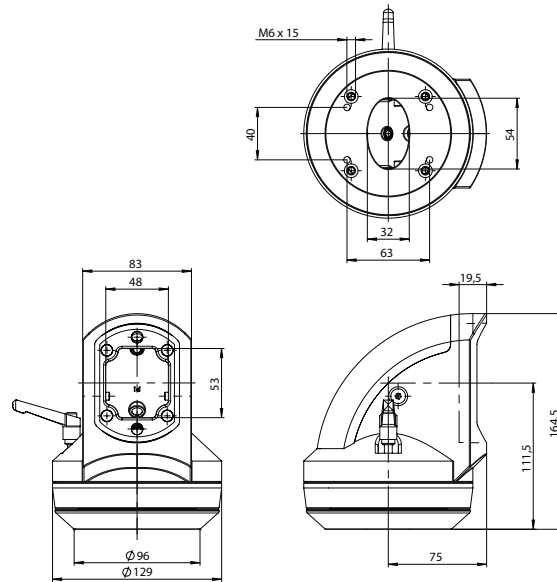

### Adapter plate GTN II-PRO

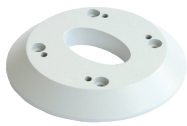

Order No.      Execution

**49.47 00 01**      for connecting GTN II elements with Siemens Pro command units  
(not relevant for coupling GTN II Pro and angle coupling GTN II Pro)

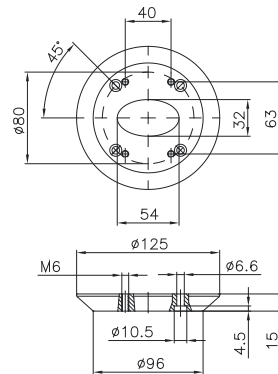

### Foot stand fixed



Order No.      Execution

**49.47 72 00**      Diecast aluminium, fixed version, for ground mounting or wall mounting

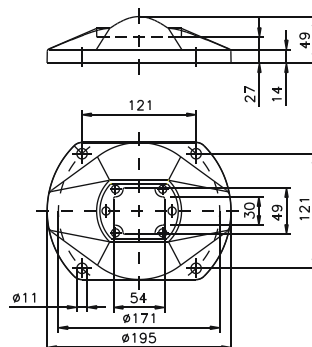

**Components**

**Foot stand turnable with adapter plate**

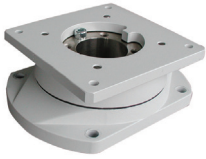

Order No.      Execution

**49.47 72 20**      Diecast aluminium with adjustable stop position between machine and control panel for the combination of directly with commander, **not with profile**

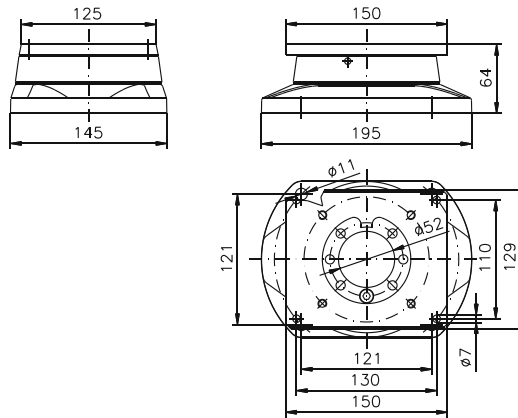

**Foot stand turnable**

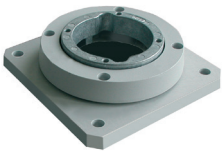

Order No.      Execution

**49.47 72 21**      Diecast aluminium with adjustable stop position between machine and control panel for the combination of directly with commander, **not with profile**

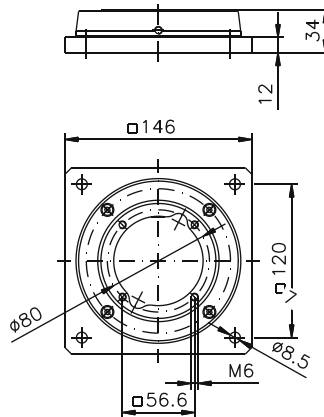

**Console flange 15°**



Order No.      Execution

**49.47 76 00**      Aluminium flange with 15° inclination

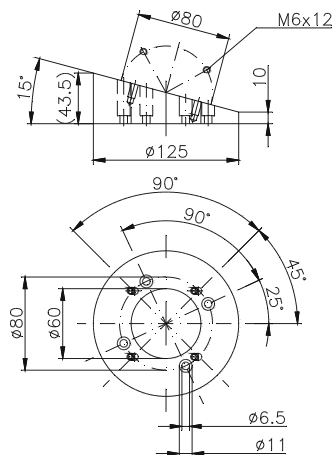

# GTN II

## Components

### Column



Order No.

Execution

**49.47 00 04**

Steel, painted, length individually up to 2 m, including adapter plate for GTN II top mounted joint, at bottom side flange outlet (specify total length)

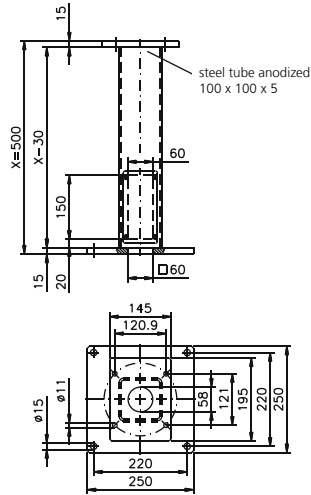

### Inclining adapter



Order No.

Execution

**49.47 80 00**

Diecast aluminium part with bellows and seal, inclination can be adjusted to any angle between  $0^\circ$  and  $45^\circ$ .

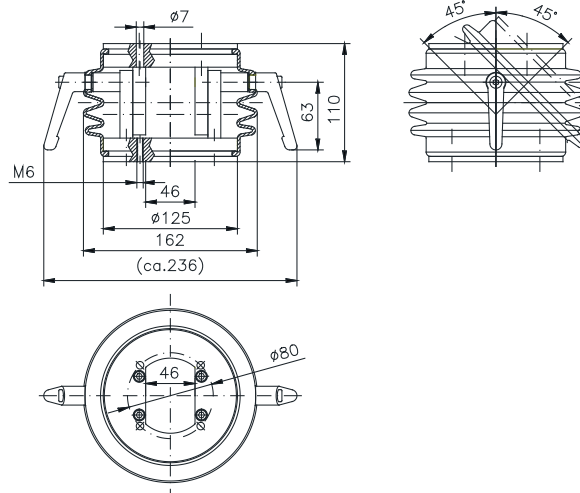



**Components**

**Profile**



Order No.      Execution

**s. page 101**      Extruded aluminium sheath, open version with integrated cable channel with black rubber cover

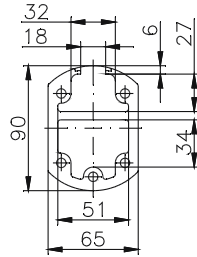

Profile open

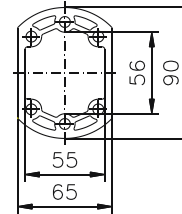

Profile closed

**Height adjustment unit GTN II / GT 48/2**

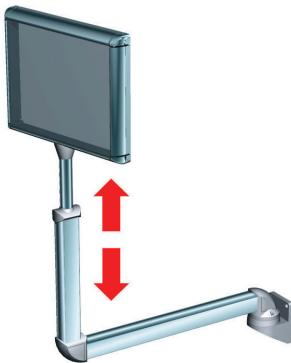

Order No.      Execution

**49.47 30 01**      Height adjustment „tube in tube“ consisting of: combination GTN II / GT 48/2 tube incl. coupling GT 48/2  
 height adjustment area: 250 mm  
 length of tube GTN II: 515 mm; total length 645 - 895 mm from lower edge GTN II-tube  
 max. loading: 25 kg  
 free cable entry: 40 mm  
 other length GTN II-tube on request

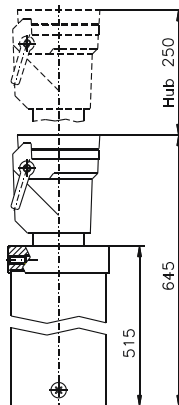

Components

Height adjustment, slide hanging



Order No.

Execution

**49,47 30 02**

Consisting of tube GTN II open, slide and swivel joint, slide fixing on rear side of the commander system, adjustment by knob  
 height adjustment area: 200 mm (damped by gas spring)  
 total length of tube: 730 mm  
 max. loading: 30 kg  
 swivel range: 330°

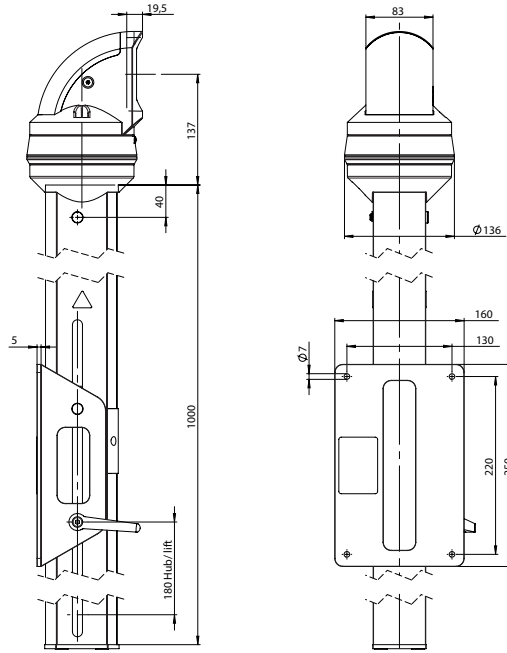

Height adjustment, slide standing



Order No.

Execution

**49,47 30 03**

Consisting of tube GTN II open, slide and swivel joint, slide fixing on rear side of the commander system, adjustment by knob  
 height adjustment area: 200 mm (damped by gas spring)  
 total length of tube: 730 mm  
 max. loading: 30 kg  
 swivel range: 330°

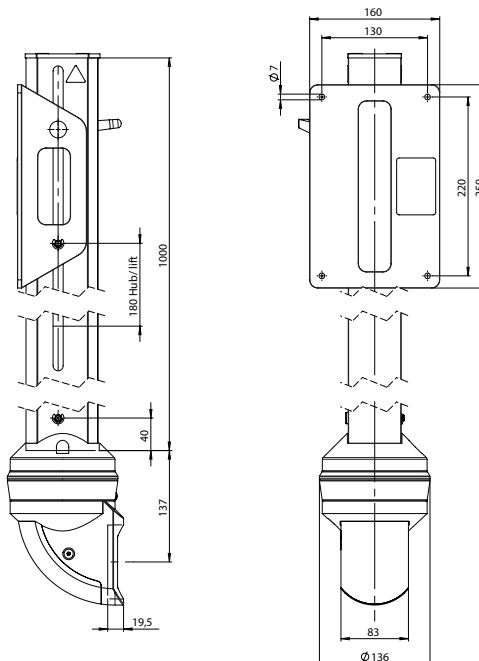

## Components

### Base connection element for suspension systems, command units and cabinets



Order No.      Execution

**49.00 01 01**      Signal light adaptation with thread M20x1.5 mm

**49.00 01 02**      Signal light adaptation with thread M22x1.5 mm

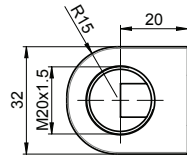
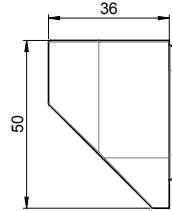
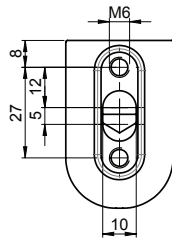

**49.00 01 01**

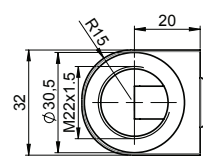

**49.00 01 02**

### Base connection element for suspension systems, command units and cabinets



Order No.      Execution

**49.00 01 03**      Signal light adaption with tube Ø 25 mm, length = 250 mm

**49.00 01 04**      Signal light adaption with tube Ø 25 mm, length = 150 mm

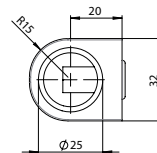
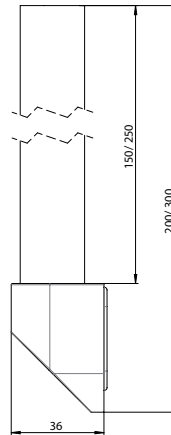
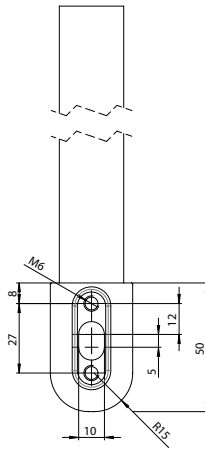

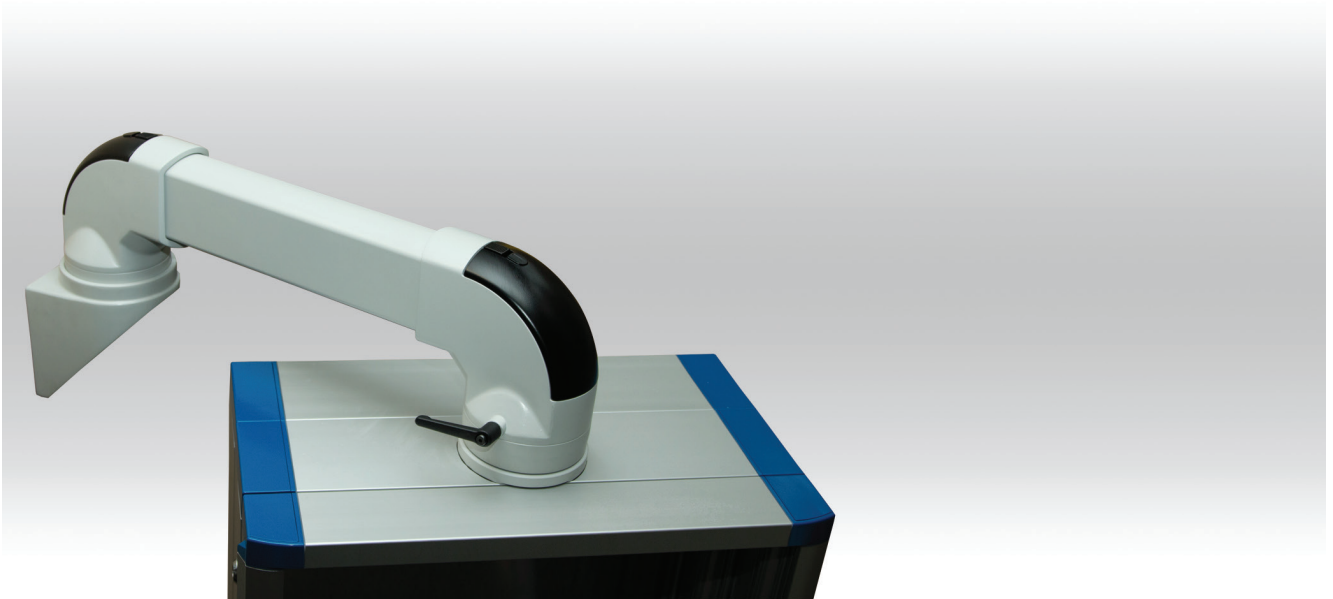

- + Aluminium profile suspension system for heavy loads
- + Complete product family GTS – GTN II – GTL product family
- + Can be combined with GTN II suspension system / height adjustment system GTV and control enclosures
- + Optional adjustment for horizontal alignment of the profile
- + Maximum static load 125 kg

### Included in delivery

System components with fixing material and seals

## Technical data

<b>Material</b>	Connecting tube: DIN EN 573, EN AW –AlMgSi Components: DIN EN 1706, EN AC-AISI 12 (Fe)
<b>Painting</b>	Powder coating
<b>Colour</b>	Tube and components in RAL 7035, light grey
<b>Ingress protection</b>	IP 54 to EN 60529
<b>Free cable passage</b>	Tube and components Ø 70 mm

**Product range**

Type	Order No.	Weight (g)
Top-mounted joint	<b>49.62 66 00</b>	8180
Wall hinge	<b>49.62 70 00</b>	10000
Angle	<b>49.62 71 00</b>	3120
Angle GTL / GTN II	<b>49.62 71 47</b>	4070
Foot stand	<b>49.62 72 00</b>	2770
Coupling	<b>49.62 73 00</b>	4760
Angle coupling	<b>49.62 75 00</b>	6040
Intermediate joint	<b>49.62 67 00</b>	9450

Type	Order No.	Weight (g)
<b>Aluminium profile closed RAL 7035</b>		
Standard length 0,5 m	<b>49.62 20 01</b>	4510
Standard length 1 m	<b>49.62 20 02</b>	9040
Standard length 2 m	<b>49.62 20 03</b>	18000
Standard length 3 m	<b>49.62 20 04</b>	27000
Variable length (please specify)	<b>49.62 20 99</b>	
<b>Aluminium profile closed anodized</b>		
Standard length 0,5 m	<b>49.62 21 01</b>	4510
Standard length 1 m	<b>49.62 21 02</b>	9030
Standard length 2 m	<b>49.62 21 03</b>	18000
Standard length 3 m	<b>49.62 21 04</b>	27000
Variable length (please specify)	<b>49.62 21 99</b>	
<b>Aluminium profile closed RAL 7035 for coupling GTL*</b>		
Standard length 0,5 m	<b>49.62 20 11</b>	4500
Standard length 1 m	<b>49.62 20 12</b>	9030
Variable length (please specify)	<b>49.62 20 98</b>	
<b>Aluminium profile closed anodized for coupling GTL*</b>		
Standard length 0,5 m	<b>49.62 21 11</b>	4500
Standard length 1 m	<b>49.62 21 12</b>	9000
Variable length (please specify)	<b>49.62 21 98</b>	

\* Note: In case of hanging version these types are to be selected in connection with the coupling.

**Load diagram**

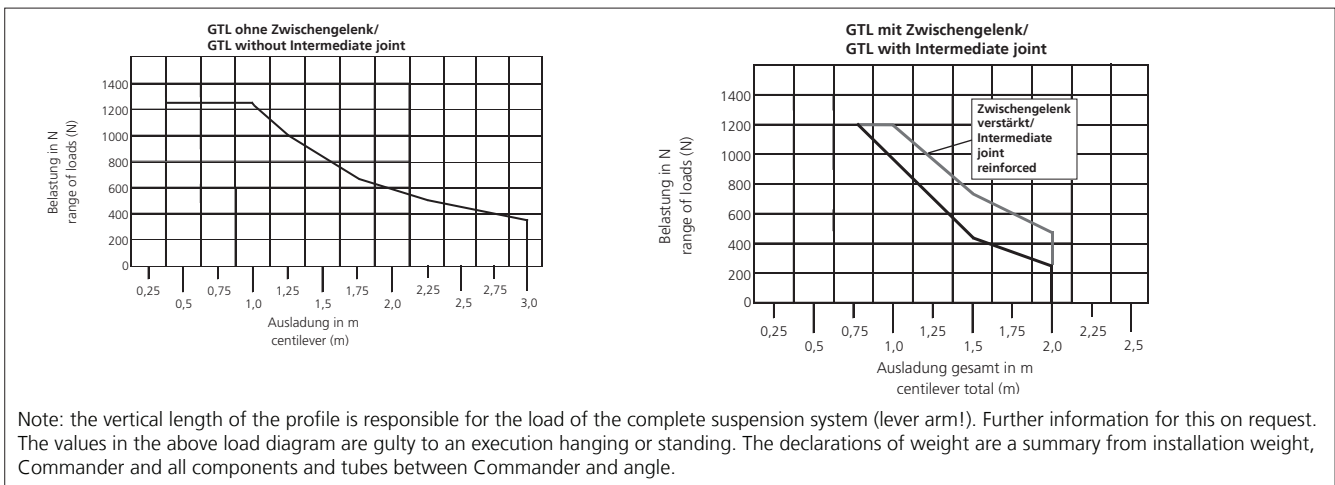

**Components**

**Angle coupling**



Order No. Execution

**49.62 75 00** Diecast aluminium with cover cap plastic  
90° angle with swivelling range 310°.  
Lockable with clamping lever.

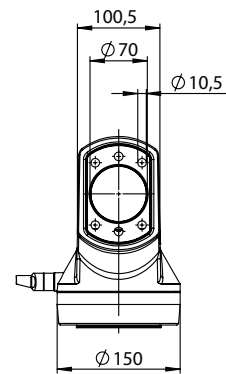
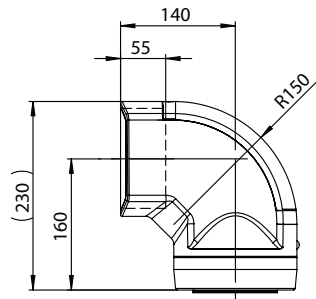
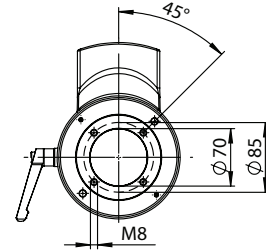

**Intermediate joint**



Order No. Execution

**49.62 67 00** Diecast aluminium with cover cap plastic  
Swivelling range 310. Lockable with clamping lever.

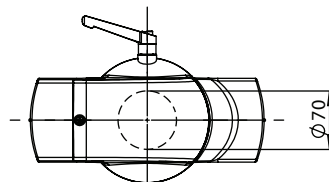
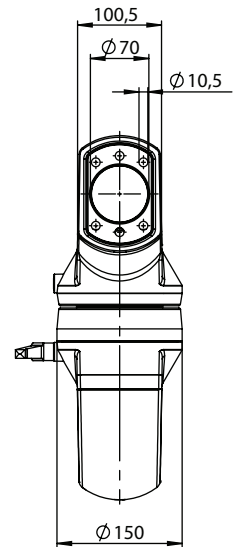
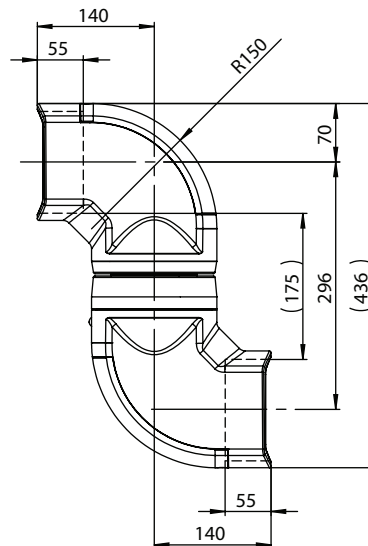

Components

Foot stand



Order No.

Execution

**49.62 72 00**

Diecast aluminium, fixed version, for floor mounting or wall mounting with rigid outlet  
incl. 4 Einstellschrauben zur horizontalen Ausrichtung

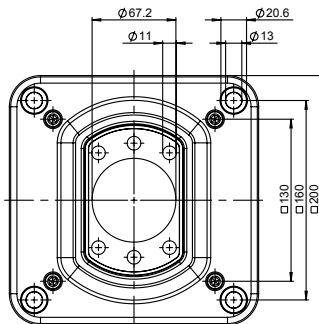
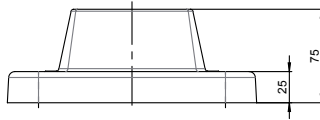

Angle GTL / GTN II



Order No.

Execution

**49.62 71 47**

for combination GTL and GTN II

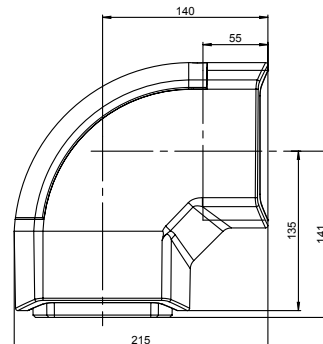
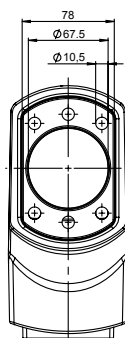
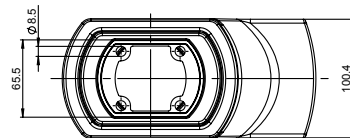

Components

Top-mounted joint

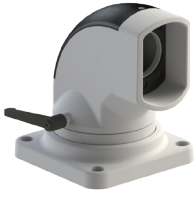

Order No. Execution

**49.62 66 00** Diecast aluminium with cover cap plastic  
Swivelling range 310°.  
Lockable with clamping lever.

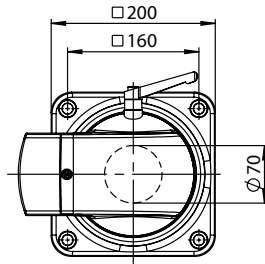
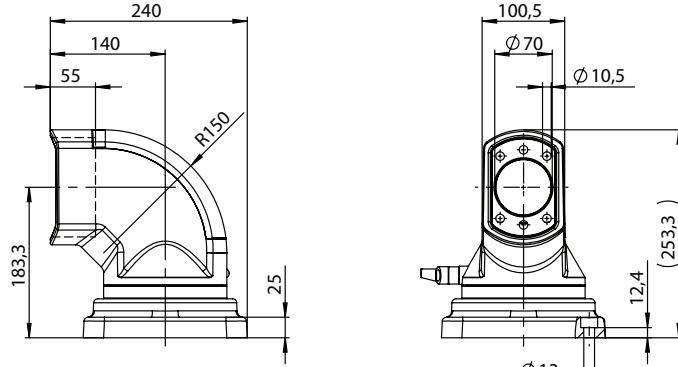

Wall hinge



Order No. Execution

**49.62 70 00** Diecast aluminium with cover cap plastic  
Swivelling range 310°.  
Lockable with clamping lever.

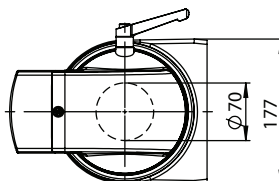
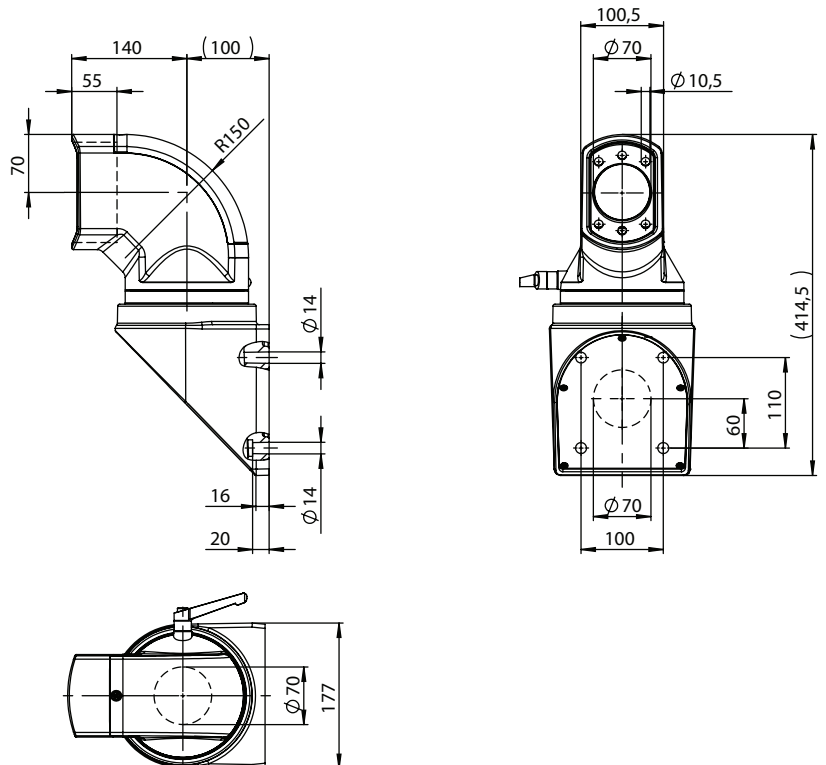



**Components**

**Angle**



Order No.	Execution
<b>49.62 71 00</b>	Diecast aluminium with cover cap plastic 90° angle

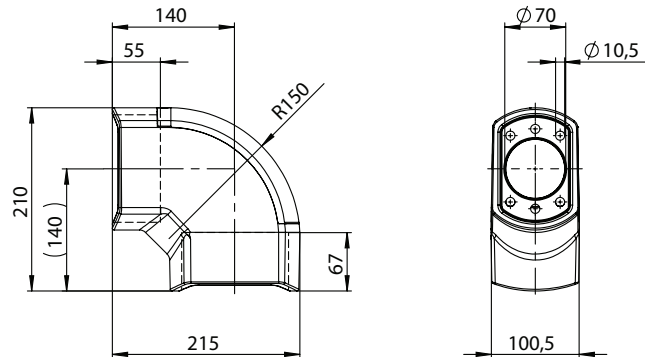

**Coupling**



Order No.	Execution
<b>49.62 73 00</b>	Diecast aluminium, Swivelling range 310°. Lockable with clamping lever. Fastening the profile from the outside.

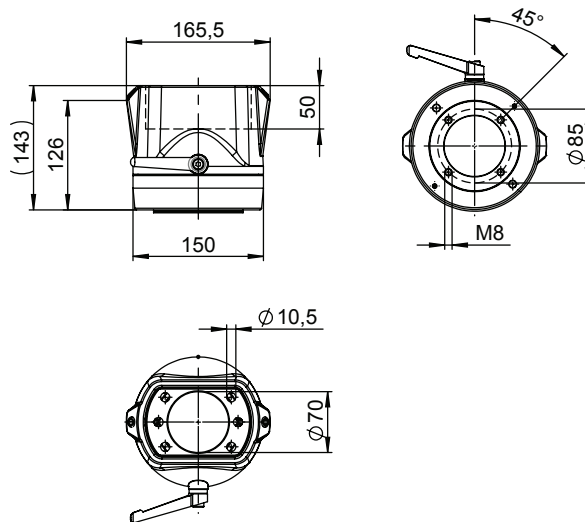

**Profile**

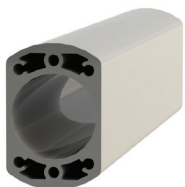

Order No.	Execution
<b>s. page 115</b>	Extruded aluminium profile

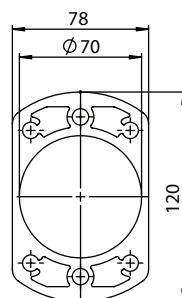

# Flat Panel Adapter



- + Connection for Panel PCs and flat control enclosures
- + Slim design
- + Protection class IP 54 with GTS/ IP 65 with GTH easy coupling
- + Comfortable access and generous assembly opening
- + Optional with angle adjustment +/- 20°

## Included in delivery

Connection compartment with lid and double ward 3mm lock. GTS or GTH easy coupling inclusive.

Optional with angle adjustment.

## Technical data

<b>Material</b>	Connection compartment: stainless steel 304 Angle adjustment: stainless steel 304 Lid: abs
<b>Surface</b>	Connection compartment: RAL 7035 Angle adjustment: RAL 7035 Lid: RAL 7021
<b>Seal</b>	CR and/or NBR
<b>Ingress protection</b>	With GTS coupling: IP 54 With GTH easy coupling: IP 65
<b>Free cable passage</b>	GTS: 53 x 19 mm GTH easy: ø 41 mm

## Product range

Order No.	Dimensions (mm) W x H x D	Variation	Cutout	Weight (kg)
50.10 20 10	193 x 199 x 104	Flat Panel Adapter GTS	VESA 75	1.89
50.10 20 20	193 x 199 x 104	Flat Panel Adapter GTS	VESA 100	1.81
50.10 20 99	193 x 199 x 104	Flat Panel Adapter GTS	special	o.req.
50.10 30 10	193 x 204 x 104	Flat Panel Adapter GTH 48 easy	VESA 75	2.39
50.10 30 20	193 x 204 x 104	Flat Panel Adapter GTH 48 easy	VESA 100	2.31
50.10 30 99	193 x 204 x 104	Flat Panel Adapter GTH 48 easy	special	o.req.
50.20 20 10	193 x 251 x 104	Flat Panel Adapter GTS with angle adjustment	VESA 75	5.26
50.20 20 20	193 x 251 x 104	Flat Panel Adapter GTS with angle adjustment	VESA 100	5.18
50.20 20 99	193 x 251 x 104	Flat Panel Adapter GTS with angle adjustment	special	o.req.
50.20 30 10	193 x 258 x 104	Flat Panel Adapter GTH 48 easy with angle adjustment	VESA 75	5.76
50.20 30 20	193 x 258 x 104	Flat Panel Adapter GTH 48 easy with angle adjustment	VESA 100	5.68
50.20 30 99	193 x 258 x 104	Flat Panel Adapter GTH 48 easy with angle adjustment	special	o.req.
50.30 40 10	193 x 214 x 149	Flat Panel Adapter GTN II	VESA 75	4.11
50.30 40 20	193 x 214 x 149	Flat Panel Adapter GTN II	VESA 100	4.03
50.30 40 99	193 x 214 x 149	Flat Panel Adapter GTN II	special	o.req.

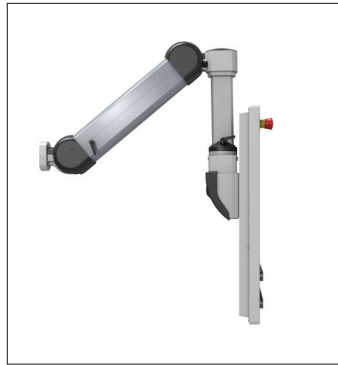
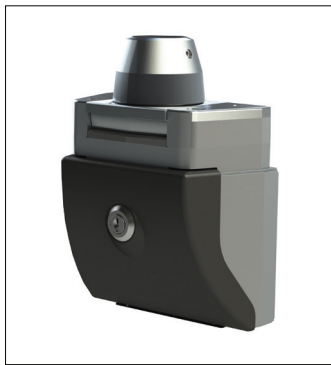

## Technical Details

### Flat Panel Adapter GTS

Order No.	Cutout
50.10 20 10	VESA 75
50.10 20 20	VESA 100
50.10 20 99	Special

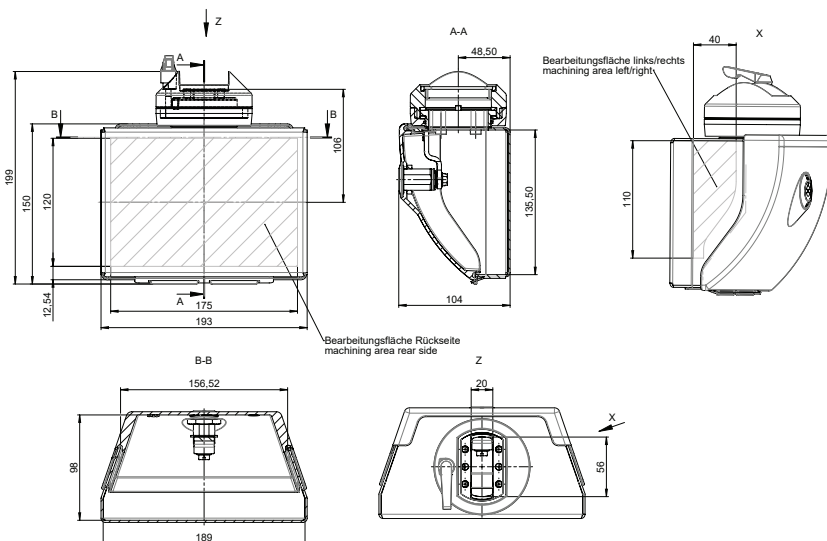

### Cutout

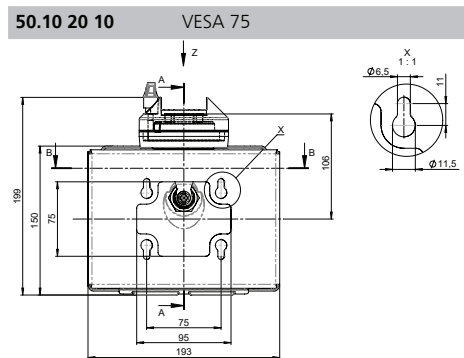

### Cutout

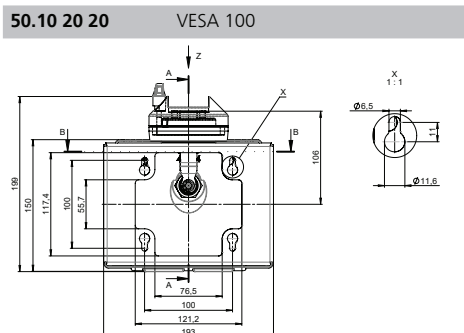

# Flat Panel Adapter

## Flat Panel Adapter GTH 48 easy

Order No.      Cutout

**50.10 30 10**      VESA 75

**50.10 30 20**      VESA 100

**50.10 30 99**      Special

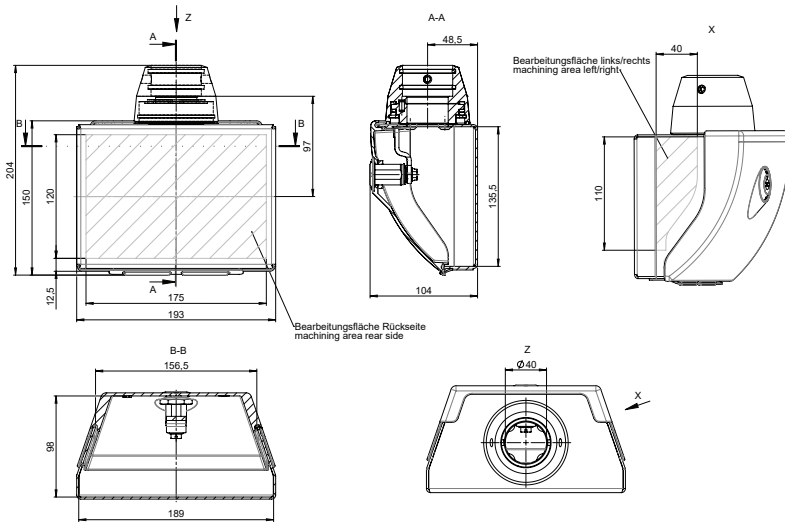

Cutout

**50.10 30 10**      VESA 75

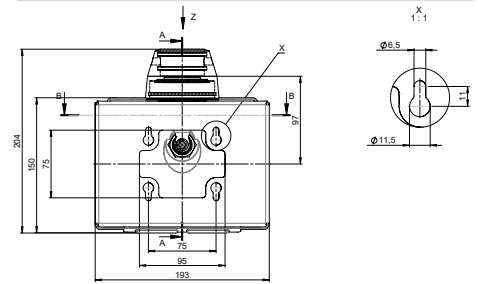

Cutout

**50.10 30 20**      VESA 100

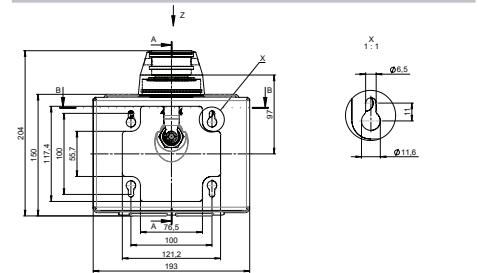

## Flat Panel Adapter GTS with angle adjustment

Order No.      Cutout

**50.20 20 10**      VESA 75

**50.20 20 20**      VESA 100

**50.20 20 99**      Special

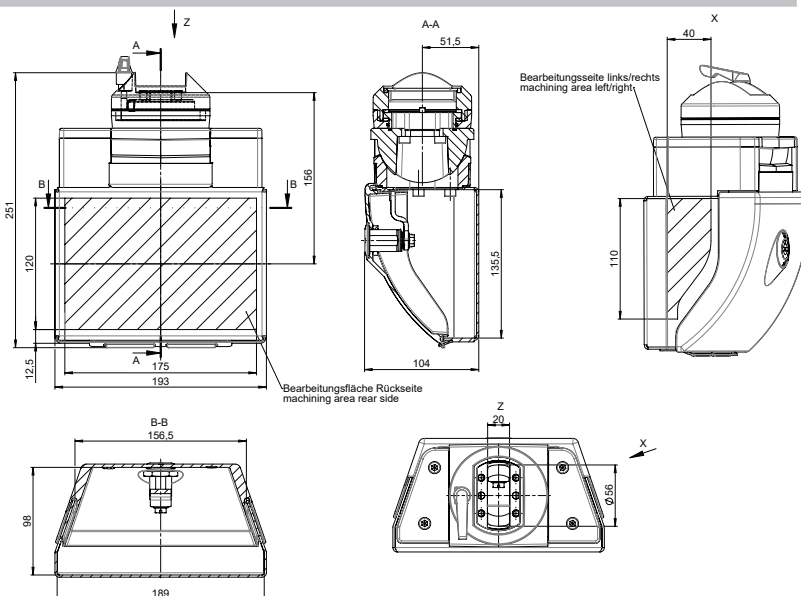

Cutout

**50.20 20 10**      VESA 75

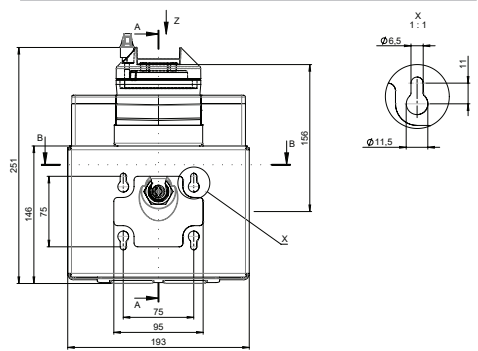

Cutout

**50.20 20 20**      VESA 100

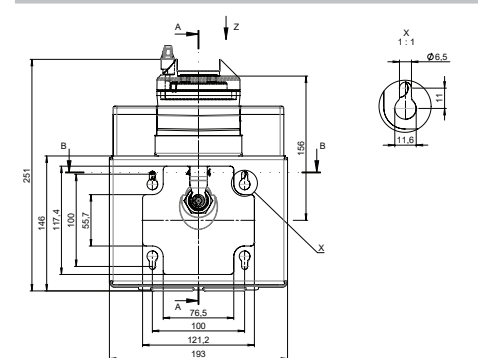

## Flat Panel Adapter GTH 48 easy with angle adjustment

Order No.	Cutout
50.20 30 10	VESA 75
50.20 30 20	VESA 100
50.20 30 99	Special

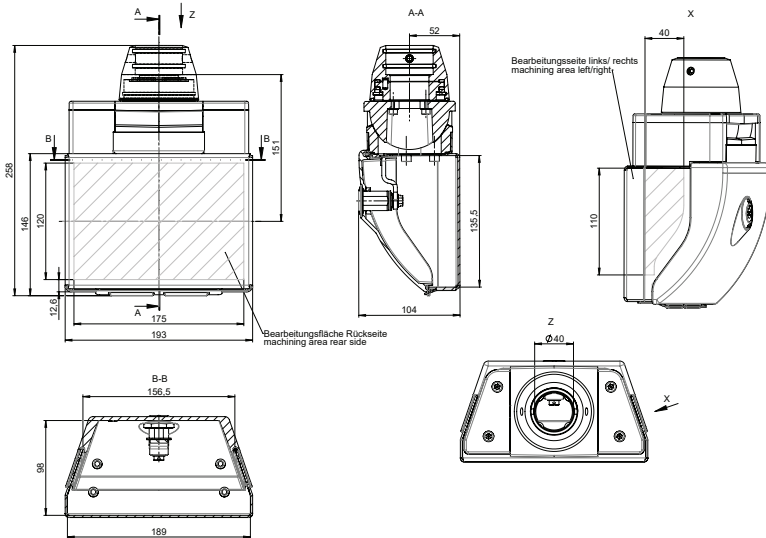

### Cutout

50.10 30 10	VESA 75
-------------	---------

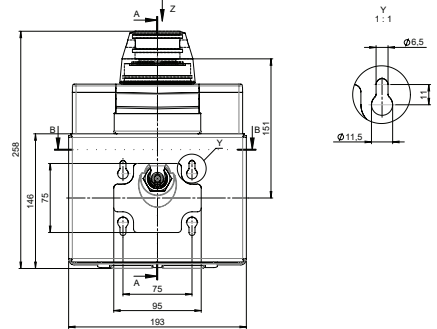

### Cutout

50.10 30 20	VESA 100
-------------	----------

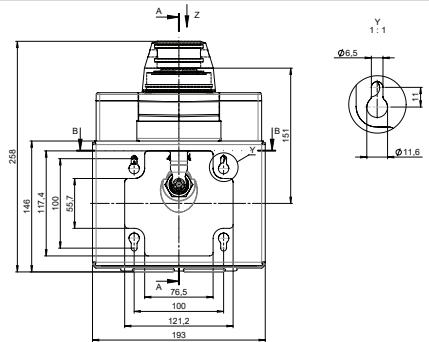

## Flat Panel Adapter GTN II

Order No.	Cutout
50.30 40 10	VESA 75
50.30 40 20	VESA 100
50.30 40 99	Special

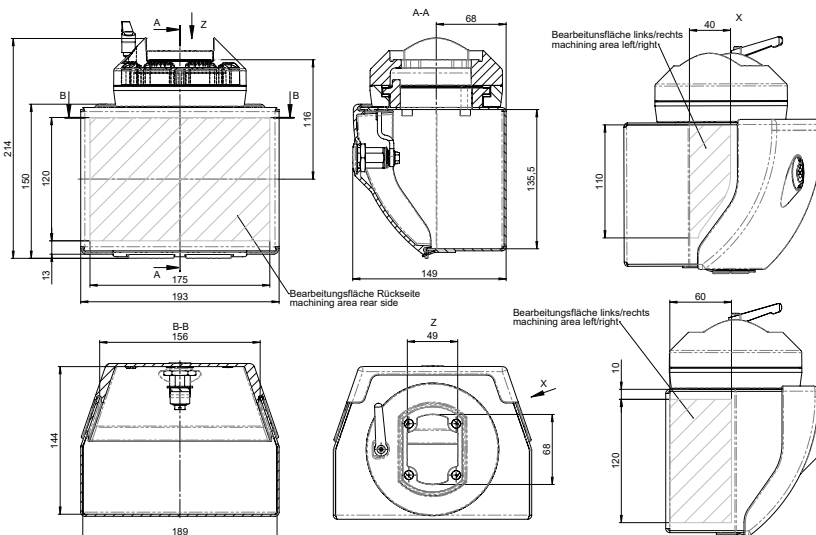

### Cutout

50.20 20 10	VESA 75
-------------	---------

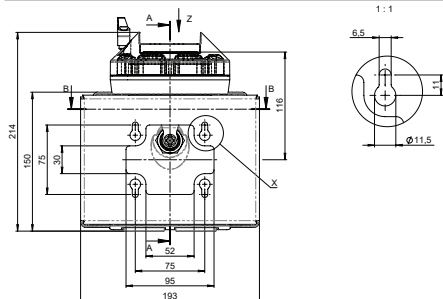

### Cutout

50.20 20 20	VESA 100
-------------	----------

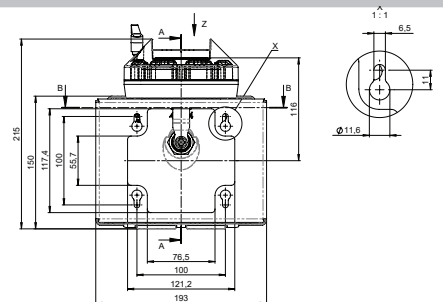

# GTV light



- + Load range 5 - 25 kg
- + 3 strokes: 400 mm / 600 mm / 800 mm
- + Step less adjustment
- + Adjustable end stops and load ranges
- + Position lockable by clamping lever
- + Possible subsequent integration into existing GTN II system
- + Spacious and easily accessible cable channel
- + Safe cable routing away from mechanical components
- + For ergonomic workplace design
- + Machine side combinable with GTN II

## Included in delivery

Height adjustment incl. fixing material (assembly components for a connection to the machine and to the control enclosure are not included).



## Technical data

Load range	5 – 25 kg
Ingress protection	IP 54
Stroke	400 / 600 / 800 mm
Weight	3,5 kg (version with 400 mm)
Temperature range	up to appr. 45°C
Life time	25.000 double strokes

## Product range

Stroke = 400 mm	Order No.
Load range 1 (5 - 10 kg)	<b>49.84 20 01</b>
Load range 2 (10 - 16 kg)	<b>49.84 20 02</b>
Load range 3 (16 - 25 kg)	<b>49.84 20 04</b>
Stroke = 600 mm	
Load range 1 (5 - 10 kg)	<b>49.84 40 01</b>
Load range 2 (10 - 16 kg)	<b>49.84 40 02</b>
Load range 3 (16 - 25 kg)	<b>49.84 40 04</b>
Stroke = 800 mm	
Load range 1 (5 - 7 kg)	<b>49.84 60 01</b>
Load range 2 (7 - 13 kg)	<b>49.84 60 02</b>
Load range 3 (13 - 21 kg)	<b>49.84 60 04</b>

The load range is calculated by:

- weight of the command unit / command housing with installations
- possibly used coupling / inclination adapter, etc.
- vertical profile up to the head of the GTV light

The load range is calculated for ambient temperature 20 °C. When using under strongly deviating temperature please contact us!

## Accessories

Adapter GTS	<b>49.84 10 01</b>
Adapter GT 48/2	<b>49.84 10 02</b>
Adapter GTK electronic	<b>49.84 10 03</b>

Note: encapsulated Panel PCs from Beckhoff and B & R (also adapter required) can be attached to 48 tube via the GT 48/2 adapter.

The adapters allow the attachments to be connected with other profile cross-section.

Adapter GT 48/2

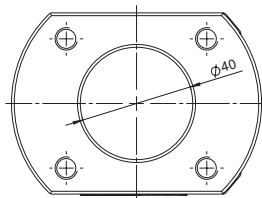

Adapter GTS

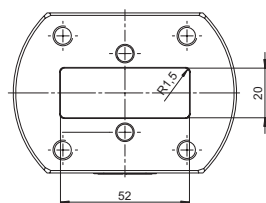

Adapter GTK electronic

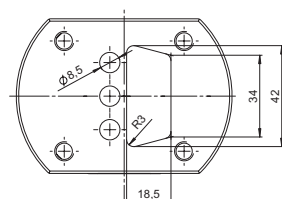

The GTV light can be precisely adjusted to the attached load in the desired load range by means of a concealed adjusting screw

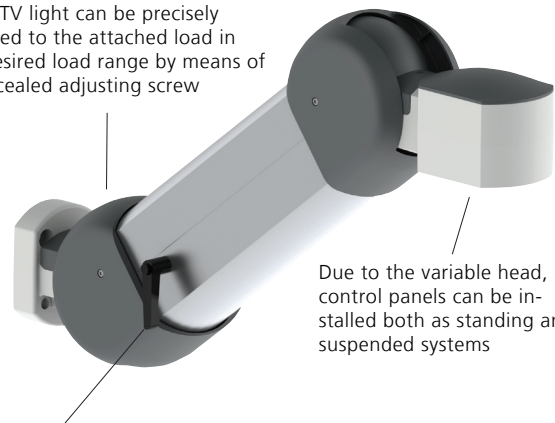

Due to the variable head, control panels can be installed both as standing and suspended systems

Brake is used for additional locking in the desired position



Maximum allowable lever not longer than 250 mm. Other lengths on request after technical clarification



# GTV light

## Technical details

### Height adjustable suspension system, outlet hanging or upright

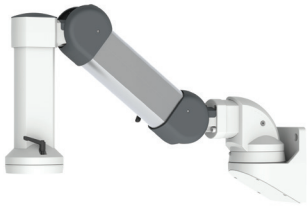

A (stroke in mm)	B (mm)	C (mm)	D (mm)
400	330	403	545
600	450	559	573
800	568	692	714

Note: The stroke of the GTV light can be steplessly limited both upwards and downwards in order to avoid collisions with possibly existing interference contours.

Minimum length between the joints (attachment joint, wall joint, intermediate joint) and GTV light = 85 mm

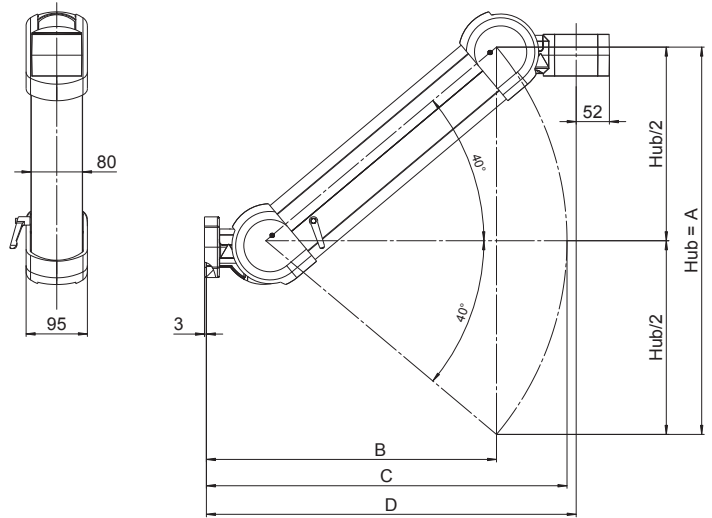
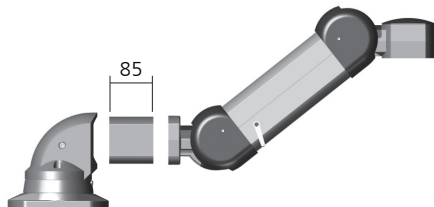

## Possible combinations

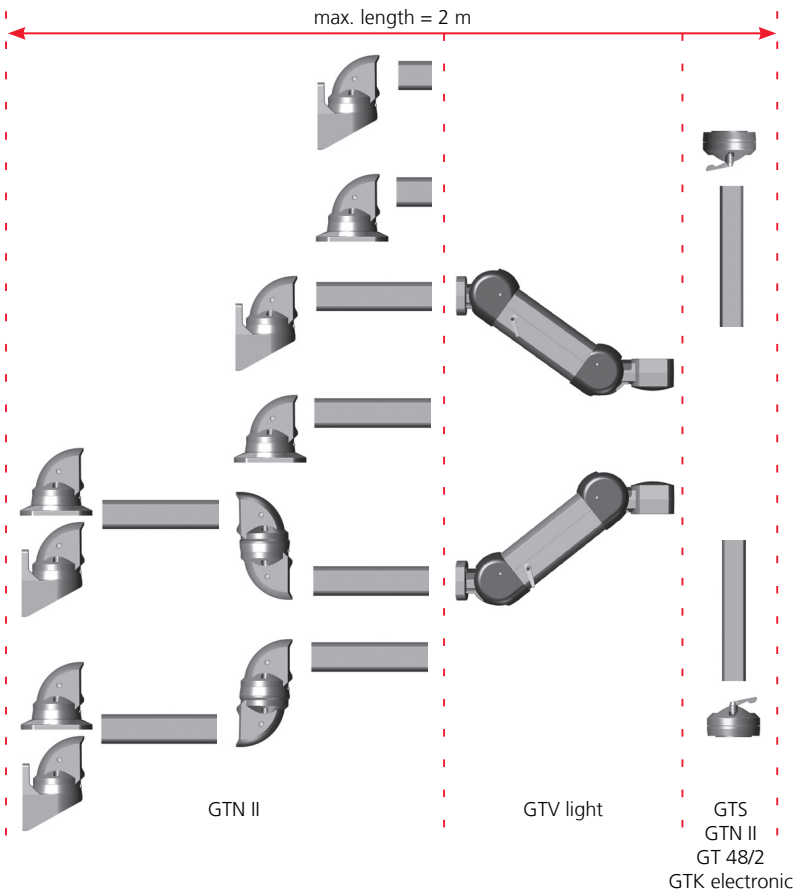



**NEW  
2.0 version**

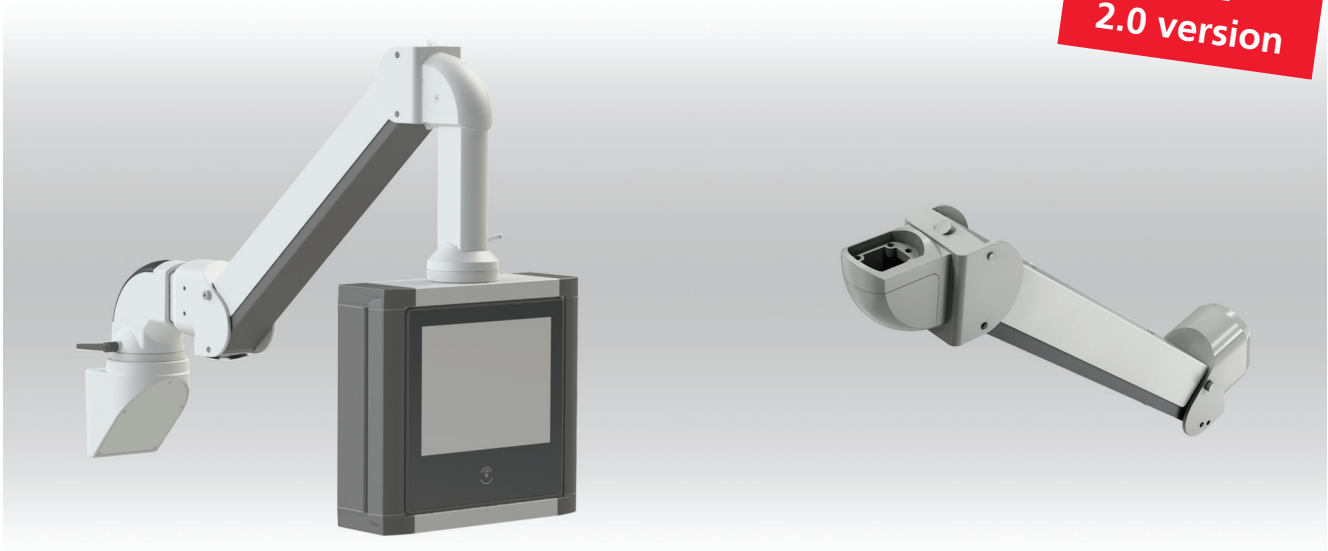

- + Load range from 20 to 60 kg
- + For making the workplace ergonomic
- + Can be combined on the machine side with the GTL suspension system
- + Can be combined on the operator side with GTN II / GT 48/2 / GTS
- + Freely positionable version
- + Adjustable binding
- + High torsional stiffness
- + Continuous potential equalisation
- + Stroke limitation every 5°

#### Included in delivery

Height adjustment incl. fixing material (assembly components for a connection to the machine and to the control enclosure are not included).

### Technical data

<b>Material</b>	Connecting plates: S235 Components: EN 1706 AC-4600DF Cable channel cover sheet: EN 573-3 AW-5754 H22
<b>Painting</b>	Powder coating
<b>Colour</b>	Connecting plates: RAL 7016 Components: RAL 7035 Cable channel cover sheet: RAL 7035
<b>Load range</b>	20 - 60 kg
<b>Life time</b>	25.000 double strokes
<b>Temperature range</b>	up to appr. 45 °C



# GTV 2.0

## Product range

	Order No.	Weight (g)
Load range 1 / Outlet hanging	<b>49.85 50 01</b>	17000
Load range 2 / Outlet hanging	<b>49.85 50 02</b>	17000
Load range 3 / Outlet hanging	<b>49.85 50 03</b>	17000
Load range 1 / Outlet upright	<b>49.85 51 01</b>	17000
Load range 2 / Outlet upright	<b>49.85 51 02</b>	17000
Load range 3 / Outlet upright	<b>49.85 51 03</b>	17000

Load range	
Load range 1:	20 – 32 kg
Load range 2:	32 – 44 kg
Load range 3:	44 – 60 kg



GTV 2.0 outlet towards suspension system GTN II for connecting command system



Suspension system GTL outlet towards machinery

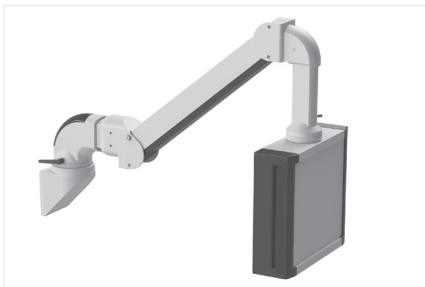

Outlet hanging

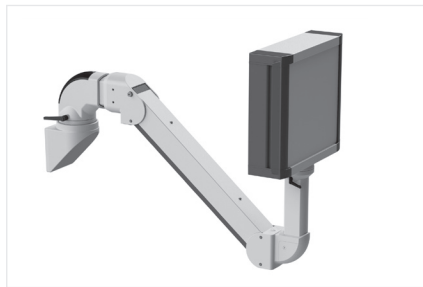

Outlet upright

## Load diagram

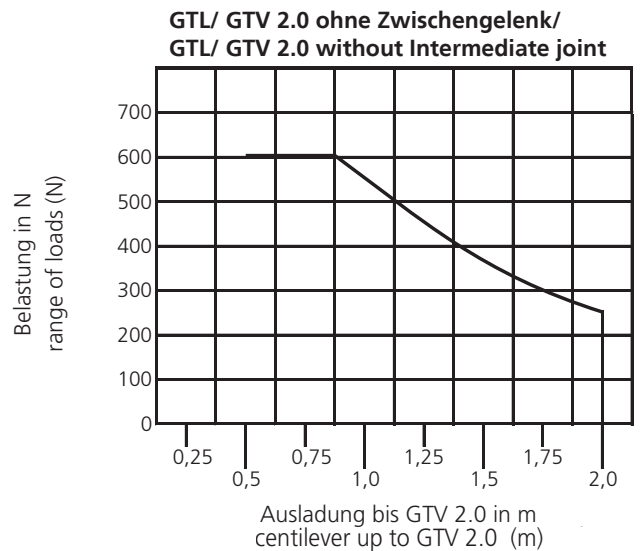
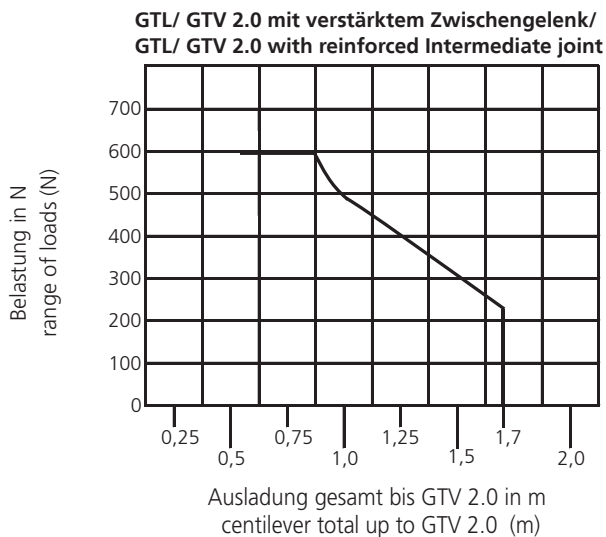

Possible combinations

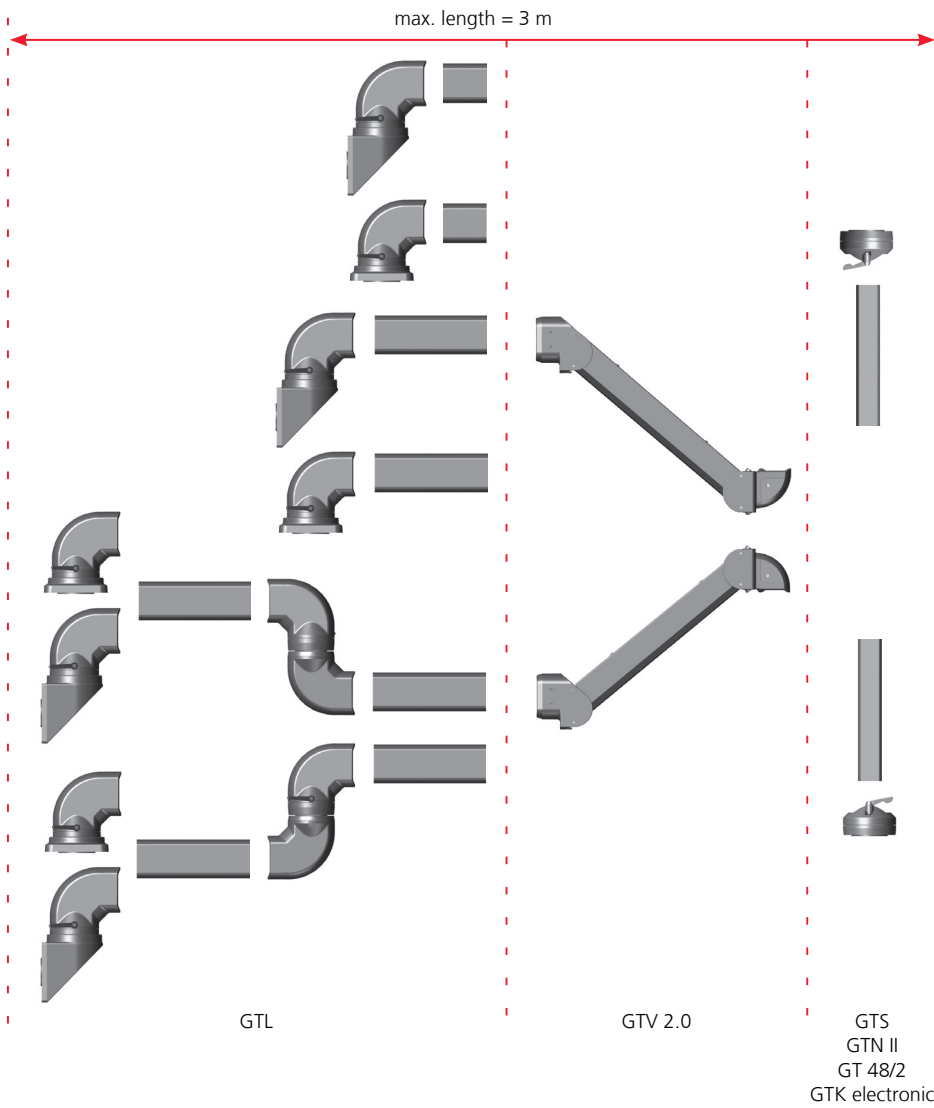

Minimum length between the joints (attachment joint, wall joint, intermediate joint) and GTV 2.0 = 150 mm

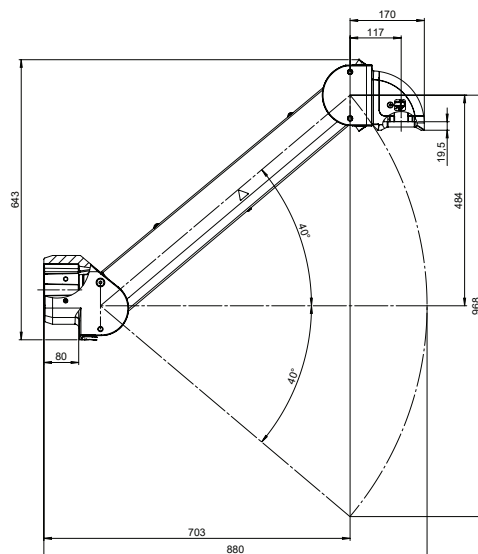
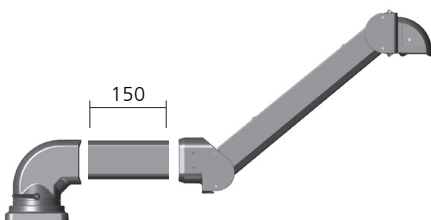

# GTV 2.0

## Technical details

### Height adjustment system, outlet hanging

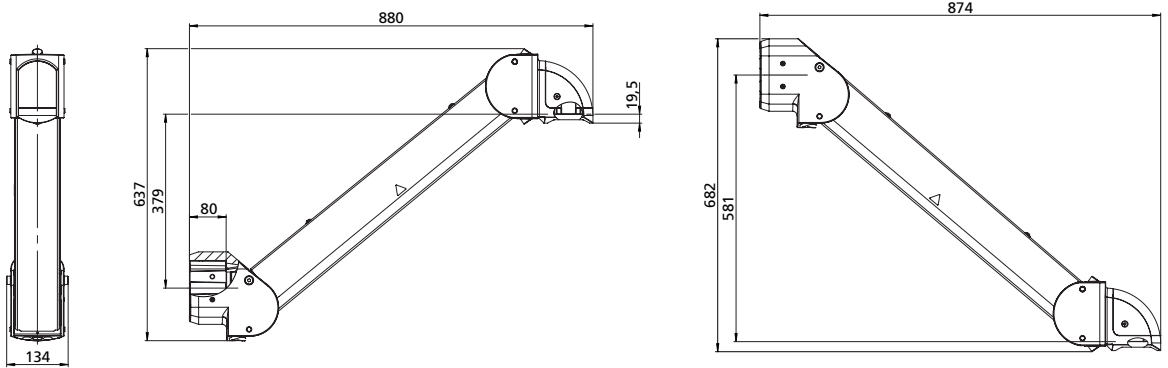
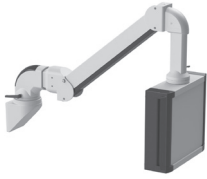

### Height adjustment system, outlet upright

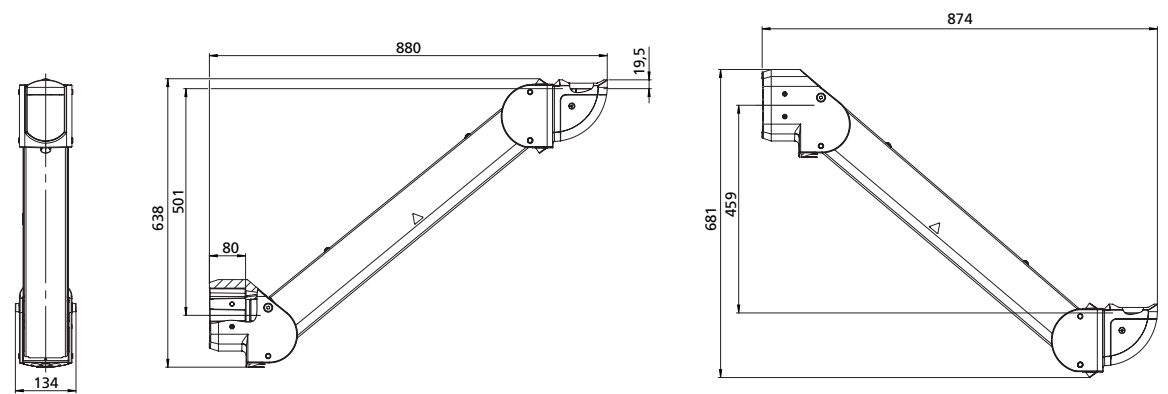
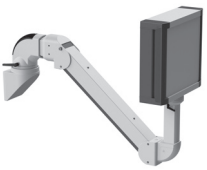



- + Stainless steel round tube system with system components
- + Tube diameter 48 and 60 mm
- + Tube Execution S-, J- and I-shape
- + Components screwed to tube
- + EMC Execution optional
- + Easy to combine with GTH easy

#### Included in delivery

System components and tube mounted if ordered

### Technical data

<b>Material</b>	Tube: stainless steel 1.4301 System components: stainless steel 1.4305
<b>Ingress protection</b>	IP 65 to EN 60529
<b>Surface</b>	Tube: grinded, grain 240
<b>Free cable passage</b>	GTH 48: 41 mm GTH 60: 53 mm
<b>Temperature range</b>	-25 °C to +60 °C



# GTH 48 / GTH 60

## Product range

	GTH 48		GTH 60	
	Order No.	Weight (g)	Order No.	Weight (g)
Coupling	<b>57.01 73 00</b>	2790	<b>57.02 73 00</b>	3390
Coupling EMC	<b>57.01 73 01</b>	2790	<b>57.02 73 01</b>	3390
Coupling for external tube fitting	<b>57.01 73 02</b>	3070	<b>57.02 73 02</b>	3680
Top-mounted joint	<b>57.01 66 00</b>	2650	<b>57.02 66 00</b>	3290
Top-mounted joint EMC	<b>57.01 66 01</b>	2630	<b>57.02 66 01</b>	3290
Top-mounted joint for external tube fitting	<b>57.01 66 02</b>	2940	<b>57.02 66 02</b>	3590
Foot stand (hanging / standing)	<b>57.01 74 00</b>	2370	<b>57.02 74 00</b>	2710
Foot stand with cable outlet (hanging / standing)	<b>57.01 72 00</b>	3120	<b>57.02 72 00</b>	3780
Console adapter	<b>57.01 76 00</b>	1290	<b>57.02 76 00</b>	1370
Console adapter hygiene	<b>57.01 76 01</b>	1290	<b>57.02 76 01</b>	1370
Wall console	<b>57.01 79 00</b>	2910	<b>57.02 79 00</b>	3120
Spare blind flange	<b>57.01 99 00</b>		<b>57.02 99 00</b>	
Tube I (500 mm)	<b>57.01 00 05</b>	1760	<b>57.02 00 05</b>	2490
Tube I (1000 mm)	<b>57.01 00 10</b>	3530	<b>57.02 00 10</b>	5000
Tube I (1500 mm)	<b>57.01 00 15</b>	5300	<b>57.02 00 15</b>	7500
Tube I special length	<b>57.01 00 99</b>		<b>57.02 00 99</b>	
Tube S (500 mm)	<b>57.01 02 05</b>	3520	<b>57.02 02 05</b>	4340
Tube S (1000 mm)	<b>57.01 02 10</b>	5300	<b>57.02 02 10</b>	6580
Tube S Sonderlänge	<b>57.01 02 99</b>		<b>57.02 02 99</b>	
Tube J (500 mm)	<b>57.01 01 05</b>	3510	<b>57.02 01 05</b>	4330
Tube J (750 mm)	<b>57.01 01 07</b>	5970	<b>57.02 01 07</b>	7450
Tube J (1000 mm)	<b>57.01 01 10</b>	6850	<b>57.02 01 10</b>	8570
Tube J special length	<b>57.01 01 99</b>		<b>57.02 01 99</b>	
System mounting	<b>57.00 99 00</b>		<b>57.00 99 00</b>	

## Load diagram

Suspension system GTH

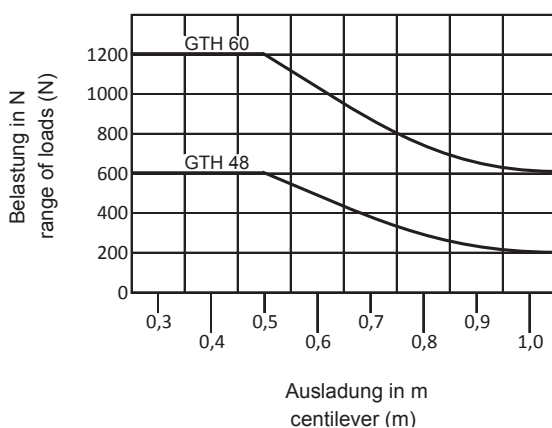

## Accessories

### Protective cap set

Order No.	Execution
<b>57.00 99 01</b>	for top-mounted joint und foot stand (4 caps)

**Components**

**Coupling**



Pivot, can be locked at any point using clamping screw.  
Swivel range: up to 350°, can be adjusted in 60° steps.

Order No.	Execution	for tube	A	B	C	D	E	F	G
GTH 48									
<b>57.01 73 00</b>	Standard	Ø 48	Ø 118	70	53	68	72	Ø 44	13
<b>57.01 73 01</b>	EMC	Ø 48	Ø 118	70	53	68	72	Ø 44	13
<b>57.01 73 02</b>	for external fitting	Ø 48	Ø 118	82	65	68	72	Ø 44	13
GTH 60									
<b>57.02 73 00</b>	Standard	Ø 60	Ø 130	81	64	85,8	68	Ø 53	13
<b>57.02 73 01</b>	EMC	Ø 60	Ø 130	81	64	85,8	68	Ø 53	13
<b>57.02 73 02</b>	for external fitting	Ø 60	Ø 130	92	75	85,8	68	Ø 53	13

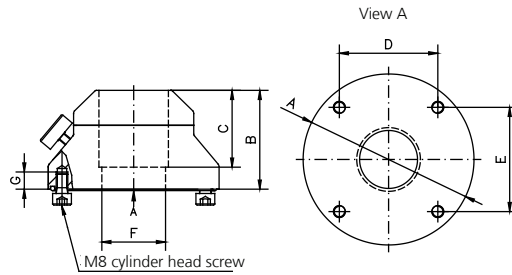

**Top-mounted joint**



Pivot, can be locked at any point using clamping screw.  
Swivel range: up to 350°, can be adjusted in 60° steps.

Order No.	Execution	for tube	A	B	C	D	E	F	G
GTH 48									
<b>57.01 66 00</b>	Standard	Ø 48	Ø 118	70	53	68	72	Ø 44	13
<b>57.01 66 01</b>	EMC	Ø 48	Ø 118	70	53	68	72	Ø 44	13
<b>57.01 66 02</b>	for external fitting	Ø 48	Ø 118	82	65	68	72	Ø 44	13
GTH 60									
<b>57.02 66 00</b>	Standard	Ø 60	Ø 130	81	64	85,8	68	Ø 53	14
<b>57.02 66 01</b>	EMC	Ø 60	Ø 130	81	64	85,8	68	Ø 53	14
<b>57.02 66 02</b>	for external fitting	Ø 60	Ø 130	92	75	85,8	68	Ø 53	14

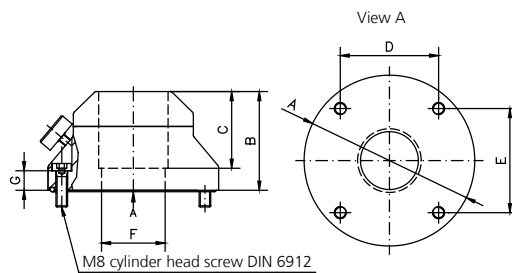

**Foot stand for base or ceiling mounting**



Order No.	Execution	for tube	A	B	C	D	E	F
GTH 48								
<b>57.01 74 00</b>	Foot stand (hanging / standing)	Ø 48	Ø 118	80	60	68	72	Ø 41,9
GTH 60								
<b>57.02 74 00</b>	Foot stand (hanging / standing)	Ø 60	Ø 130	85	60	85,8	68	Ø 53,9

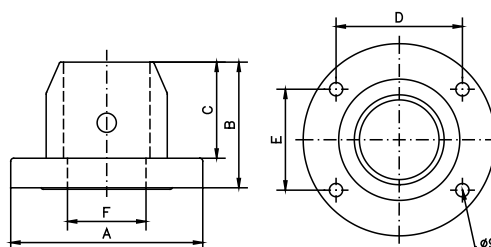

# GTH 48 / GTH 60

## Components

### Foot stand with cable outlet



for external cable outlet on side

Order No.	Execution	für Tube	A	B	C	D	E	F	G	H
GTH 48										
<b>57.01 72 00</b>	Foot stand (hanging / standing)	Ø 48	Ø 118	110	60	68	72	Ø 41,9	45	38,5
GTH 60										
<b>57.02 72 00</b>	Foot stand (hanging / standing)	Ø 60	Ø 130	115	60	85,8	68	Ø 53,9	70	38,5

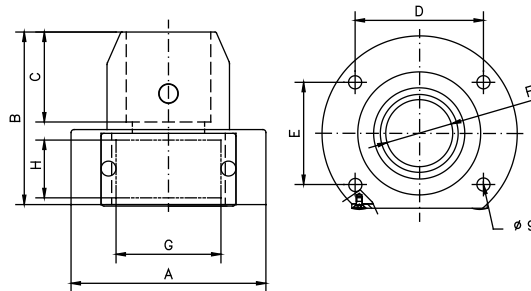

### Spare blind flange for foot stand with cable outlet



Order No.	A	B	C	D	H	I
GTH 48						
<b>57.01 99 02</b>	73	47,5	2,5	55	45	38,5
GTH 60						
<b>57.02 99 00</b>	90	48	2,5	80	70	38,5

Max. number of cable glands/ blind flange:

- 57.01 99 02: 1 x 25 or 1 x 20 or 4 x M12
- 57.02 99 00: 1 x 25 or 2 x 20 or 6 x M12

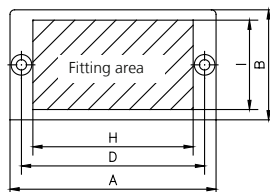
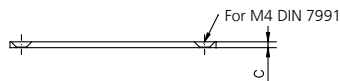

### Console adapter



Angle of inclination 14°

Order No.	for tube	A	B	C	D	E	F	G
GTH 48								
<b>57.01 76 00</b>	Ø 48,3	Ø 118	40	10,6	68	72	Ø 79	14°
GTH 60								
<b>57.02 76 00</b>	Ø 60,3	Ø 130	40	7,6	85,8	68	Ø 91	14°

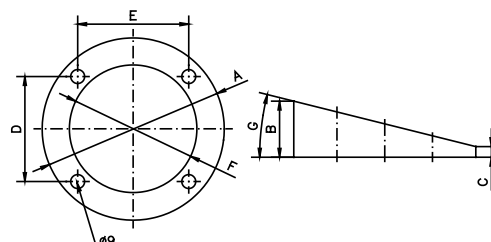





# GTH 48 / GTH 60

## Components

### Connecting tube S

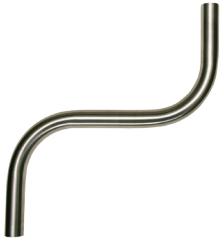

Order No.	L1 (mm)	L2 (mm)	L3 (mm)	A (outside Ø)	B (inside Ø)	Weight (g)
<b>GTH 48</b>						
<b>57.01 02 05</b>	500	300	300	48,3	41	3520
<b>57.01 02 10</b>	1000	300	300	48,3	41	5290
<b>57.01 02 99</b>	special length			48,3	41	-
<b>GTH 60</b>						
<b>57.02 02 05</b>	500	300	300	60,3	53	4340
<b>57.02 02 10</b>	1000	300	300	60,3	53	6580
<b>57.02 02 99</b>	special length			60,3	53	-

max. length L1 = 1000 mm

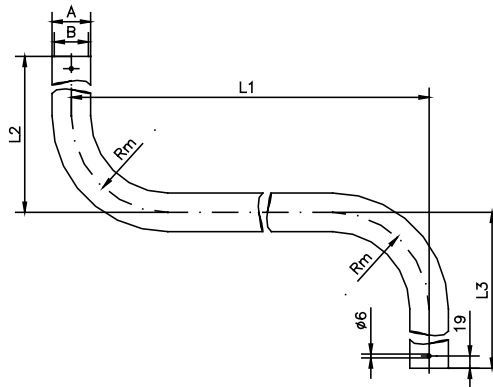

### Connecting tube J



Product info:  
Individual lengths and  
executions on request.

Order No.	L1 (mm)	L2 (mm)	L3 (mm)	A (outside Ø)	B (inside Ø)	Weight (g)
<b>GTH 48</b>						
<b>57.01 01 05</b>	500	300	300	48,3	41	3510
<b>57.01 01 07</b>	750	750	300	48,3	41	5970
<b>57.01 01 10</b>	1000	750	300	48,3	41	6850
<b>57.01 01 99</b>	special length			48,3	41	-
<b>GTH 60</b>						
<b>57.02 01 05</b>	500	300	300	60,3	53	4330
<b>57.02 01 07</b>	750	750	300	60,3	53	7450
<b>57.02 01 10</b>	1000	750	300	60,3	53	8570
<b>57.02 01 99</b>	special length			60,3	53	-

max. length L1 = 1000 mm

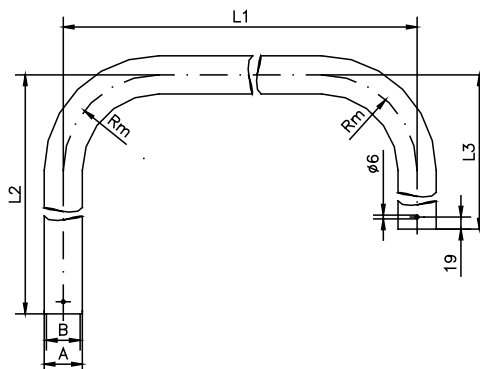

Enquiry  Order

Please copy, complete and send to: hmi@rose-pw.de

Company \_\_\_\_\_

Telephone \_\_\_\_\_

Contact \_\_\_\_\_

Fax \_\_\_\_\_

Address \_\_\_\_\_

E-Mail \_\_\_\_\_

Suspension system  GTH 48  GTH 60 Quantity \_\_\_\_\_

System consisting of the following components:

Components, side A

- Coupling
- EMC coupling
- Coupling for external tube fitting
- Top-mounted joint
- EMC top-mounted joint
- Top-mounted joint for external tube fitting
- Foot stand
- Foot stand for ceiling mounting
- Foot stand with cable outlet
- Foot stand (ceiling mounting) with cable outlet
- Console adapter
- Wall console

Connecting tube

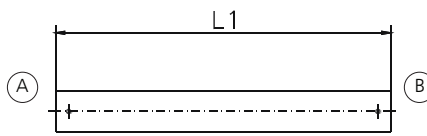

I-tube (L1)

- 500 mm
- 1000 mm
- 1500 mm
- Special length \_\_\_\_\_ mm

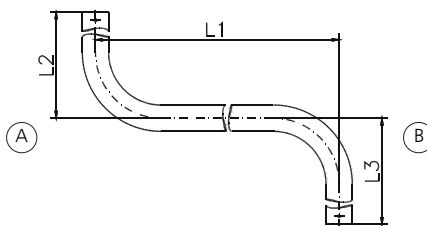

S-tube (L1/L2/L3)

- 500/300/300 mm
- 1000/300/300 mm
- Special length\* \_\_\_\_ / \_\_\_\_ / \_\_\_\_ mm

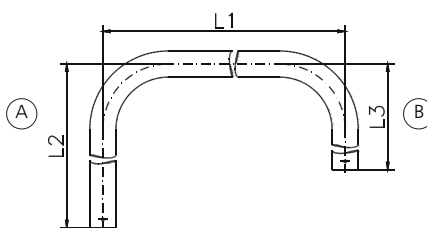

J-tube (L1/L2/L3)

- 500/300/300 mm
- 750/750/300 mm
- 1000/750/300 mm
- Special length\* \_\_\_\_ / \_\_\_\_ / \_\_\_\_ mm

\* Attention: measure dimension tube center  
min. lengths L2 and L3: 280 mm  
max. lengths L1 = 1000 mm

Components, side B

- Coupling
- EMC coupling
- Coupling for external tube fitting
- Top-mounted joint
- EMC top-mounted joint
- Top-mounted joint for external tube fitting
- Foot stand
- Foot stand for ceiling mounting
- Foot stand with cable outlet
- Foot stand (ceiling mounting) with cable outlet
- Console adapter
- Wall console

Accessories

- Protective cap set
- Spare blind flange untreated
- Spare blind flange treated \_\_\_\_\_



## GTH 48 easy / GTH 60 easy

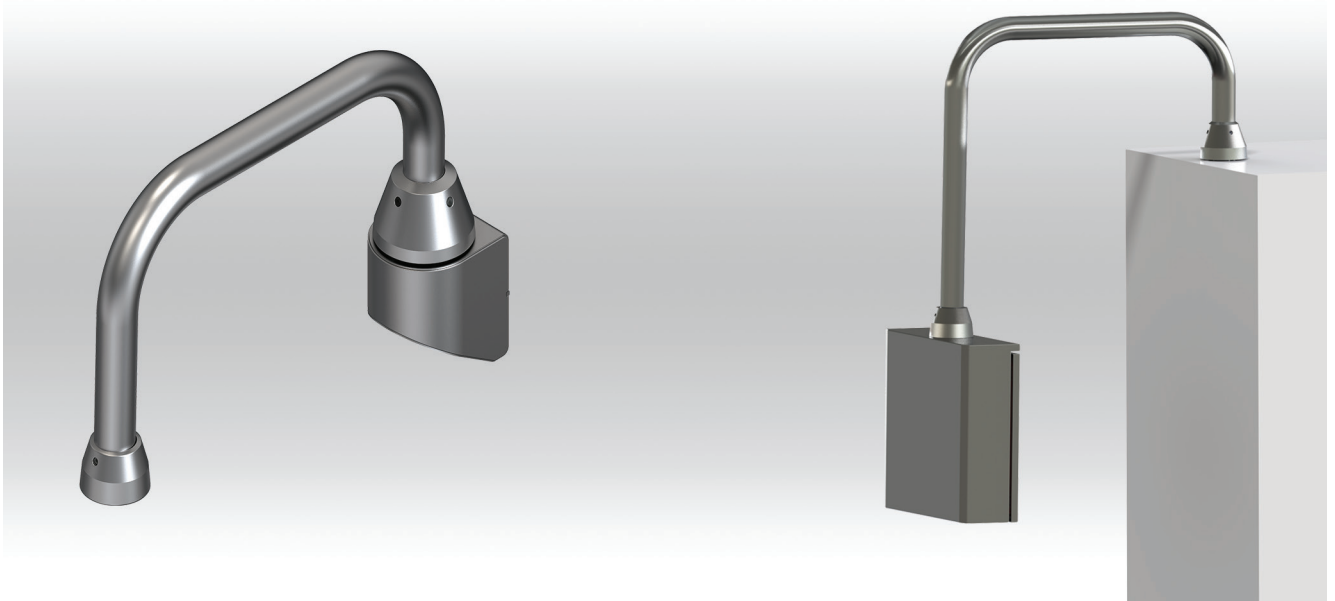

- + Stainless steel round tube system with system components
- + Tube diameter 48 and 60 mm
- + Tube Execution S-, J- and I-shape
- + Very compact design
- + Little assembly effort
- + Up to IP rating: IP 69
- + Easy to combine with GTH

### Included in delivery

System components and tube mounted if ordered

### Technical data

<b>Material</b>	Tube: stainless steel 1.4301/ 304 Components: stainless steel 1.4301/ 304
<b>Ingress protection</b>	IP 66 / IP 69 to EN 60529
<b>Surface</b>	Tube: grinded, grain 240
<b>Free cable passage</b>	GTH 48: 41 mm GTH 60: 53 mm
<b>Temperature range</b>	-25 °C to +60 °C

**Product range**

Type	GTH 48 easy		GTH 60 easy	
	Order No.	Weight (g)	Order No.	Weight (g)
Coupling	<b>57.03 73 00</b>	993	<b>57.04 73 00</b>	2710
Top-mounted joint	<b>57.03 66 00</b>	3200	<b>57.04 66 00</b>	3780
Console adapter	<b>57.03 76 00</b>	637	<b>57.04 76 00</b>	1190
Wall console	<b>57.03 79 00</b>	2230	<b>57.04 79 00</b>	2230
Tube I (500 mm)	<b>57.03 00 05</b>	1760	<b>57.04 00 05</b>	2490
Tube I (1000 mm)	<b>57.03 00 10</b>	3530	<b>57.04 00 10</b>	4990
Tube I (1500 mm)	<b>57.03 00 15</b>	5300	<b>57.04 00 15</b>	7500
Tube I special length	<b>57.03 00 99</b>		<b>57.04 00 99</b>	
Tube S (500 mm)	<b>57.03 02 05</b>	3520	<b>57.04 02 05</b>	4340
Tube S (1000 mm)	<b>57.03 02 10</b>	5290	<b>57.04 02 10</b>	6580
Tube S special length	<b>57.03 02 99</b>		<b>57.04 02 99</b>	
Tube J (500 mm)	<b>57.03 01 05</b>	3510	<b>57.04 01 05</b>	4330
Tube J (750 mm)	<b>57.03 01 07</b>	5970	<b>57.04 01 07</b>	7450
Tube J (1000 mm)	<b>57.03 01 10</b>	6850	<b>57.04 01 10</b>	8560
Tube J special length	<b>57.03 01 99</b>		<b>57.04 01 99</b>	

**Load diagram**

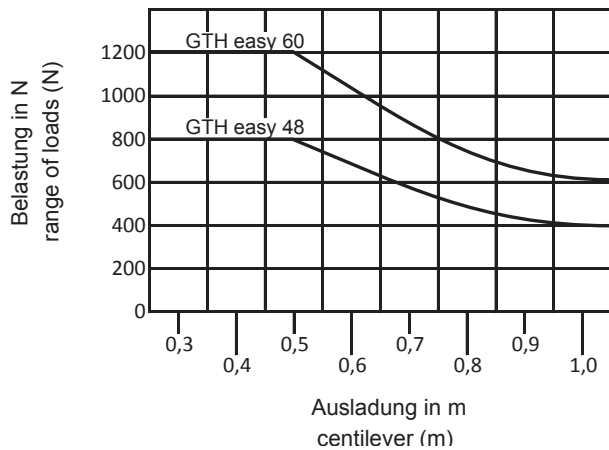

# GTH 48 easy / GTH 60 easy

## Components

### Coupling



Swivelling range 330°

Order No.	for tube	A	B	C	D	E	F	G
GTH 48 easy								
<b>57.03 73 00</b>	Ø 48	82	57,6	30	33,6	33,6	40	13
GTH 60 easy								
<b>57.04 73 00</b>	Ø 60	112	76,2	40	46	46	50	13

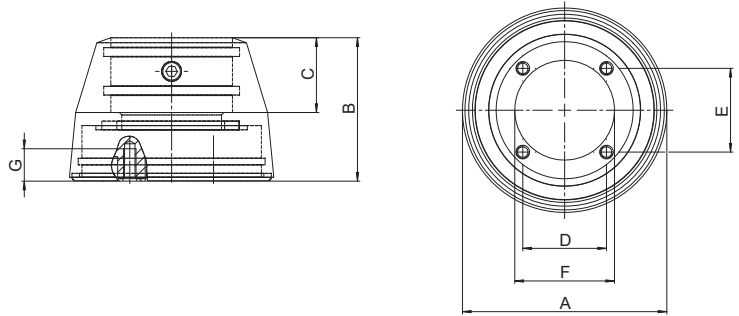

### Top-mounted joint



Swivelling range 330°

Order No.	for tube	A	B	C	D	E	F	G
GTH 48 easy								
<b>57.03 66 00</b>	Ø 48	119	81,7	40	46	46	40	10
GTH 60 easy								
<b>57.04 66 00</b>	Ø 60	119	96,7	50	46	46	50	10

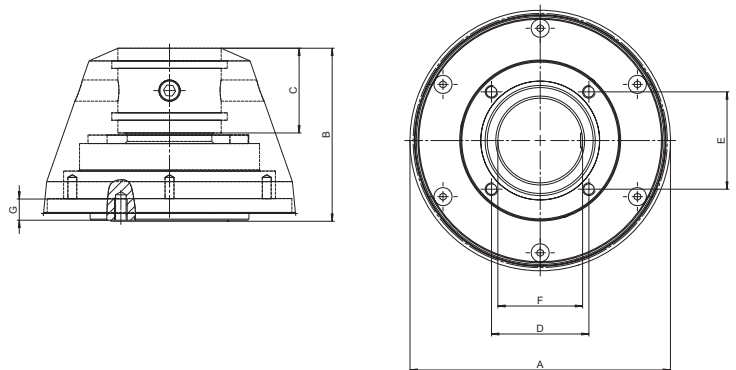

**Components**

**Console adapter**



Order No.	for tube	A	B	C	D	E	F	G
GTH 48 easy								
<b>57.03 76 00</b>	Ø 48,3	82	30	9,6	33,6	33,6	40	14°
GTH 60 easy								
<b>57.04 76 00</b>	Ø 60,3	112	33	5	46	46	50	14°

Angle of inclination 14°

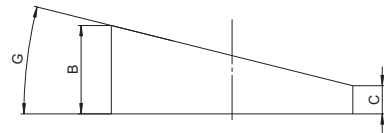
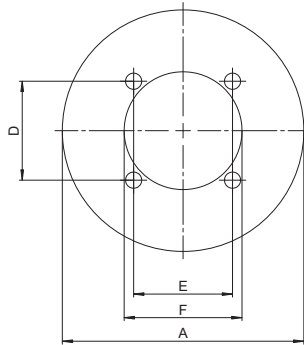

# GTH 48 easy / GTH 60 easy

## Components

### Wallconsole



for adaption top-mounted joint or coupling

Order No. for tube

GTH 48 easy

**57.03 79 00** Ø 48

GTH 60 easy

**57.04 79 00** Ø 60

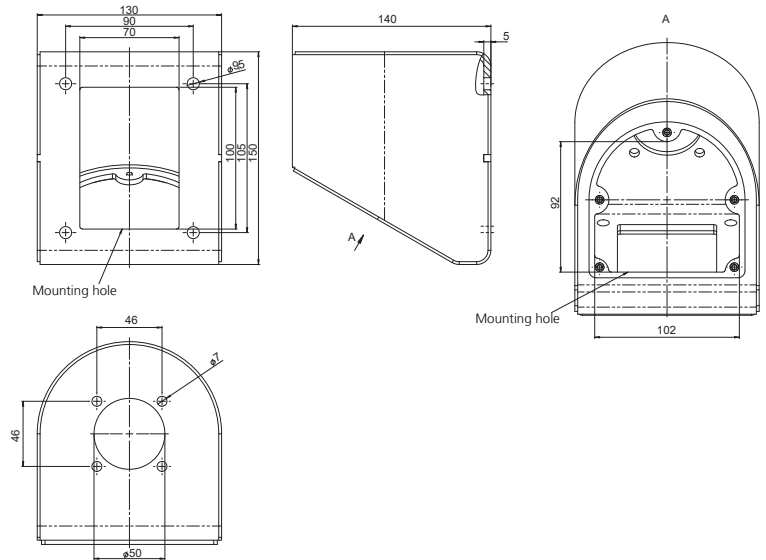

### Connecting tube I



Order No.	L1 (mm)	A (außen Ø)	B (innen Ø)	Weight (g)
GTH 48 easy				
<b>57.03 00 05</b>	500	48,3	41,9	1760
<b>57.03 00 10</b>	1000	48,3	41,9	3530
<b>57.03 00 15</b>	1500	48,3	41,9	5300
<b>57.03 00 99</b>	special length	48,3	41,9	-
GTH 60 easy				
<b>57.04 00 05</b>	500	60,3	53,1	2490
<b>57.04 00 10</b>	1000	60,3	53,1	4990
<b>57.04 00 15</b>	1500	60,3	53,1	7500
<b>57.04 00 99</b>	special length	60,3	53,1	-

max. length L1 = 1000 mm

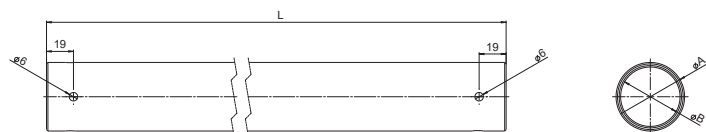



**Components**

**Connecting tube S**



Order No.	L1	L2	L3	A	B	Rm	Weight (g)
GTH 48 easy							
<b>57.03 02 05</b>	500	300	300	48,3	41,9	120	3520
<b>57.03 02 10</b>	1000	300	300	48,3	41,9	120	5290
<b>57.03 02 99</b>	special length			48,3	41,9	120	-
GTH 60 easy							
<b>57.04 02 05</b>	500	300	300	60,3	53,1	150	4340
<b>57.04 02 10</b>	1000	300	300	60,3	53,1	150	6580
<b>57.04 02 99</b>	special length			60,3	53,1	150	-

max. length L1 = 1000 mm

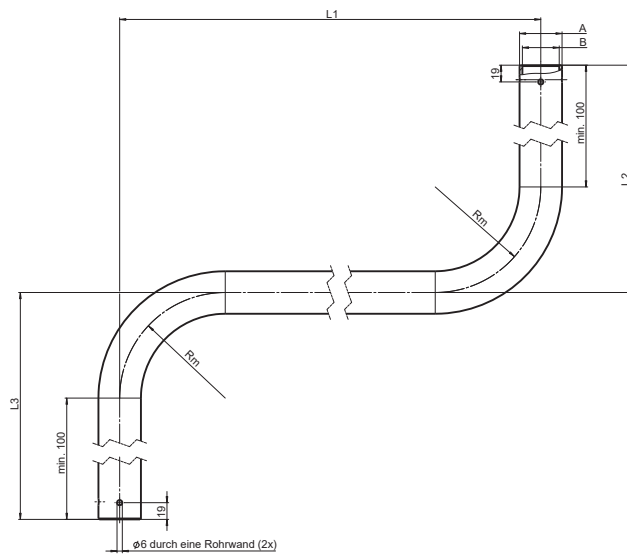

**Connecting tube J**



**Product info:**

Individual lengths and executions on request.

Order No.	L1	L2	L3	A	B	Rm	Weight (g)
GTH 48 easy							
<b>57.03 01 05</b>	500	300	300	48,3	41,9	120	3510
<b>57.03 01 07</b>	750	750	300	48,3	41,9	120	5970
<b>57.03 01 10</b>	1000	750	300	48,3	41,9	120	6850
<b>57.03 01 99</b>	special length			48,3	41,9	120	-
GTH 60 easy							
<b>57.04 01 05</b>	500	300	300	60,3	53,1	150	4330
<b>57.04 01 07</b>	750	750	300	60,3	53,1	150	7450
<b>57.04 01 10</b>	1000	750	300	60,3	53,1	150	8660
<b>57.04 01 99</b>	special length			60,3	53,1	150	-

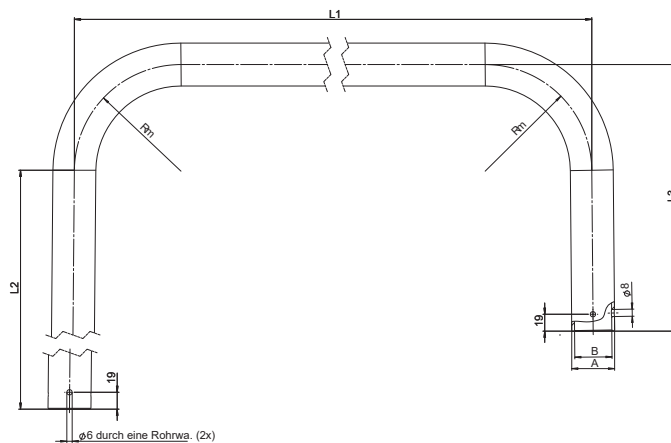

# GTH 48 easy / GTH 60 easy

Enquiry       Order

Please copy, complete and send to: hmi@rose-pw.de

Company \_\_\_\_\_

Telephone \_\_\_\_\_

Contact \_\_\_\_\_

Fax \_\_\_\_\_

Address \_\_\_\_\_

E-Mail \_\_\_\_\_

Suspension system       GTH 48 easy       GTH 60 easy      Quantity \_\_\_\_\_

System consisting of the following components:

### Components, side A

- Coupling
- EMC coupling
- Coupling for external tube fitting
- Top-mounted joint
- EMC top-mounted joint
- Top-mounted joint for external tube fitting
- Foot stand
- Foot stand for ceiling mounting
- Foot stand with cable outlet
- Foot stand (ceiling mounting) with cable outlet
- Console adapter
- Wall console

### Connecting tube

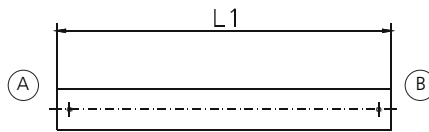

I-tube (L1)

- 500 mm
- 1000 mm
- 1500 mm
- Special length \_\_\_\_\_ mm

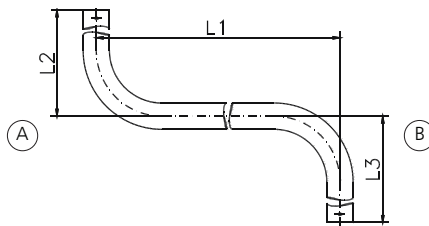

S-tube (L1/L2/L3)

- 500/300/300 mm
- 1000/300/300 mm
- Special length\* \_\_\_\_\_ / \_\_\_\_\_ / \_\_\_\_\_ mm

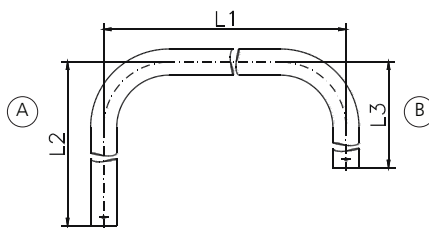

J-tube (L1/L2/L3)

- 500/300/300 mm
- 750/750/300 mm
- 1000/750/300 mm
- Special length\* \_\_\_\_\_ / \_\_\_\_\_ / \_\_\_\_\_ mm

\* Attention: measure dimension tube center  
 min. lengths L2 and L3: 280 mm  
 max. lengths L1 = 1000 mm

### Components, side B

- Coupling
- Top-mounted joint
- Console adapter
- Wall console

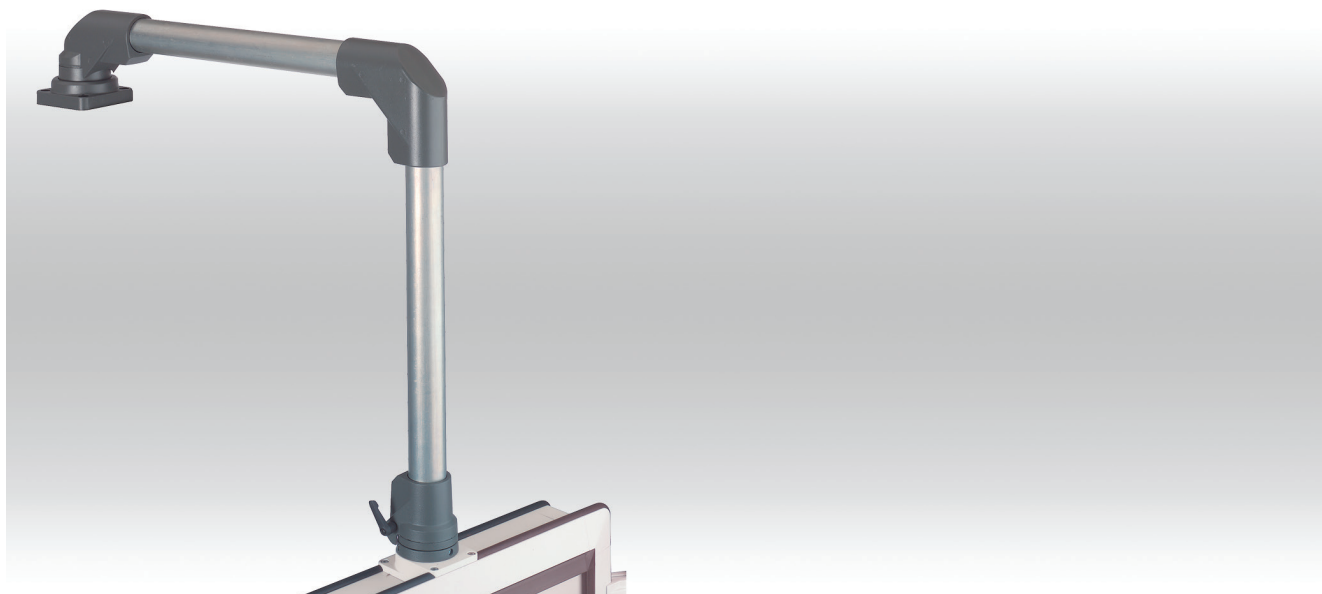

- + Industrial round tube system for commander systems
- + Modular construction for individual components
- + Protected internal cable routing

#### Included in delivery

Individual system components incl.  
assembly materials

### Technical data

<b>Material</b>	Connecting tube: steel 48 x 4 mm DIN 2393-St. 37 Components: DIN EN 1706 EN AC-AISI 12 (Fe)
<b>Painting</b>	Powder coating
<b>Colour</b>	Tube: galvanized Components: RAL 7043, traffic grey B, Special colour on request
<b>Ingress protection</b>	IP 54 to EN 60529



## Product range

Type	Order No.	Weight (g)
Top-mounted joint	<b>49.49 66 00</b>	2070
Foot stand, fixed	<b>49.49 72 00</b>	739
Foot stand, turnable	<b>49.49 68 00</b>	1840
Wall hinge W	<b>49.49 70 00</b>	2920
Wall hinge S	<b>49.49 62 00</b>	2660
Angle	<b>49.49 71 00</b>	927
Coupling	<b>49.49 73 00</b>	988
Flange coupling	<b>49.49 77 00</b>	859
Flange coupling GT 48/2-PRO	<b>49.49 77 02</b>	1060
Angle coupling	<b>49.49 75 00</b>	1220
Flange angle coupling	<b>49.49 78 00</b>	1090
Flansch angle coupling GT 48/2-PRO	<b>49.49 78 02</b>	1290
Console flange 30°	<b>49.49 76 00</b>	319
Adapter flange	<b>49.49 79 00</b>	2000
Inclining adapter	<b>49.49 80 00</b>	818
Adapter plate GT 48/2-PRO	<b>49.45 00 01</b>	175

Connecting tube	Order No.	Weight (g)
Standard length: 0,5 m	<b>10.09 42 16</b>	2180
Standard length: 1 m	<b>10.09 42 17</b>	4350
Standard length: 2 m	<b>10.09 42 18</b>	8700
Standard length: 3 m	<b>10.09 42 19</b>	13050
Variable length (please specify)	<b>10.09 41 58</b>	

## Load diagram

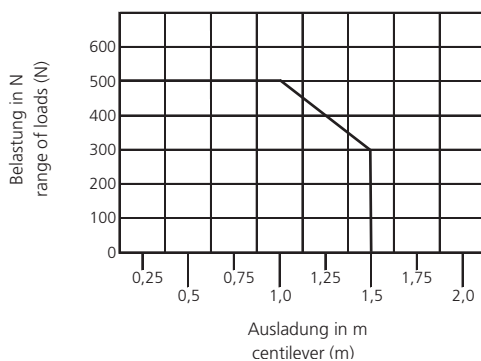

Note: the vertical length of the profile is responsible for the load of the complete suspension system (lever arm!).

Further information for this on request. The values in the above load diagram are guilty to an execution hanging or standing.

The declarations of weight are a summary from installation weight, Commander and all components and tubes between Commander and angle.

## System structure

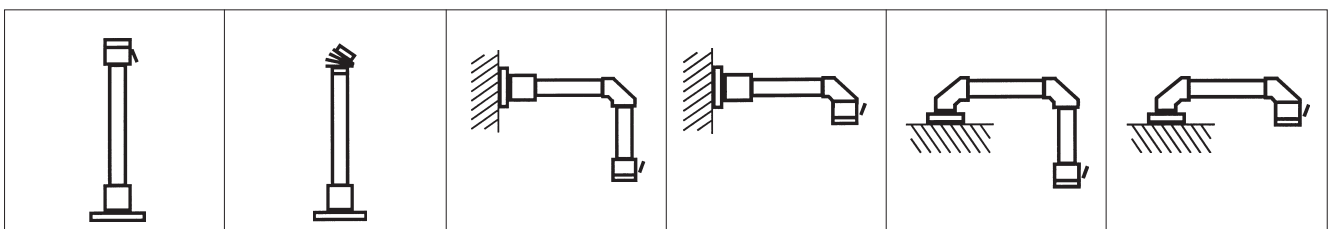

**Components**

**Top mounted joint**



Order No.      Execution

**49.49 66 00**      Diecast aluminium with steel inner tube and flange mounting.  
Swivelling range 250°

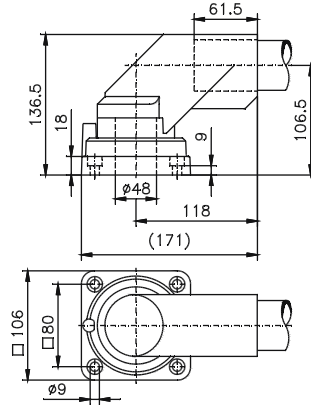

**Wall hinge W (horizontal)**



Order No.      Execution

**49.49 70 00**      Diecast aluminium with steel inner tube and flange mounting.  
Swivelling range 250°

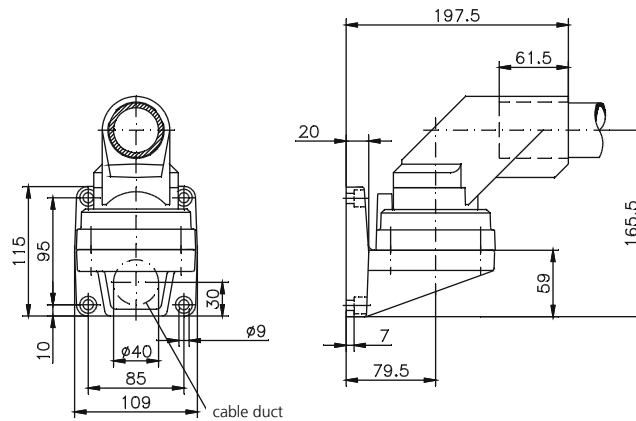

**Wall hinge S (vertical)**



Order No.      Execution

**49.49 62 00**      Diecast aluminium with steel inner tube and flange mounting.  
Swivelling range 250°

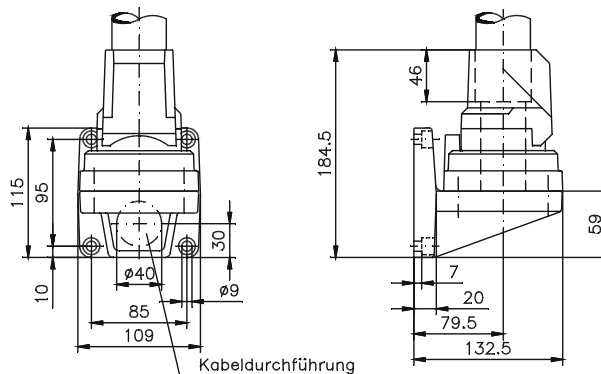

**Components**

**Angle**



Order No.	Execution
<b>49.49 71 00</b>	Diecast aluminium. Angle 90°

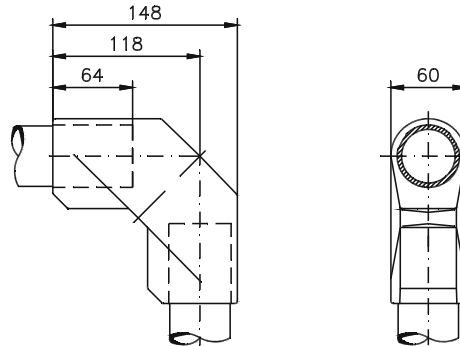

**Coupling**



Order No.	Execution
<b>49.49 73 00</b>	Diecast aluminium with steel inner tube. Swivelling range 270°. Lockable with clamping lever.

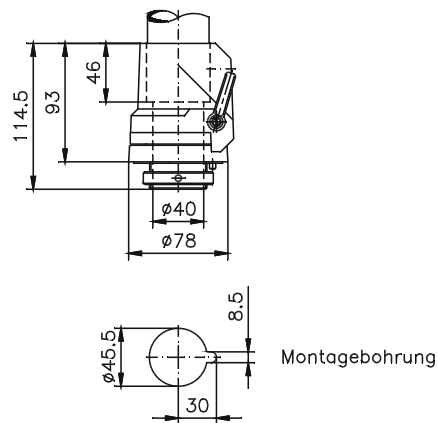

**Foot stand fixed**



Order No.	Execution
<b>49.49 72 00</b>	Diecast aluminium, fixed version

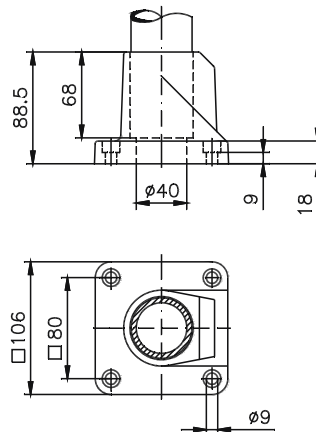

## Components

### Foot stand turnable



Order No. Execution

**49.49 68 00** Diecast aluminium with steel inner tube and flange mounting.  
Swivelling range 250°

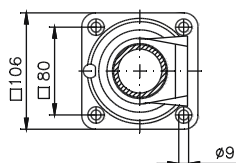
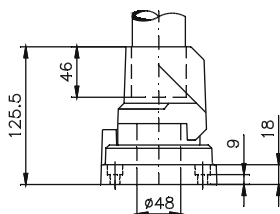

### Flange coupling



Order No. Execution

**49.49 77 00** Diecast aluminium with steel inner tube.  
Swivelling range 270°.  
Lockable with clamping lever.

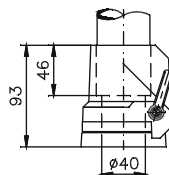
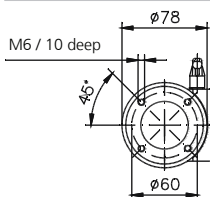

### Flange coupling GT 48/2 Pro



Order No. Execution

**49.49 77 02** for direct mounting of Siemens Pro command units.  
Diecast aluminium with steel inner tube.  
Swivelling range 270°.  
Lockable with clamping lever.

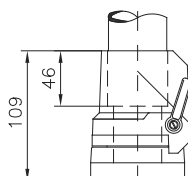
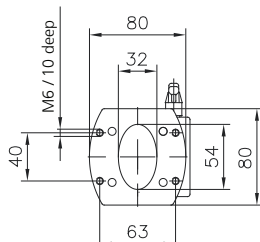

**Components**

**Angle coupling**



Order No.      Execution

**49.49 75 00**      Combination of angle and coupling for horizontal tube exit. Cast aluminium with steel inner tube. Swivelling range 270°. Lockable with clamping lever

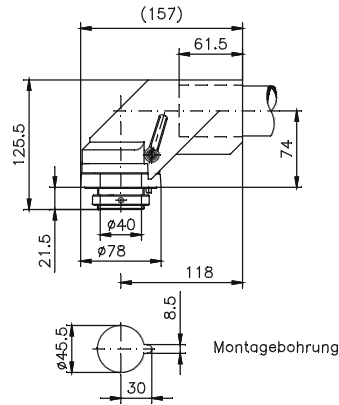

**Flange angle coupling**



Order No.      Execution

**49.49 78 00**      Combination of angle and coupling for horizontal tube exit. Diecast aluminium with steel inner tube. Swivelling range 270°. Lockable with clamping lever

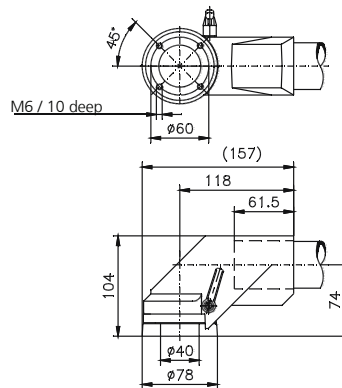

**Flange angle coupling GT 48/2 Pro**

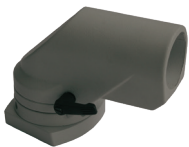

Order No.      Execution

**49.49 78 02**      for direct mounting of Siemens Pro command units  
Combination of angle and coupling for horizontal tube exit. Cast aluminium with steel inner tube. Swivelling range 270°. Lockable with clamping lever

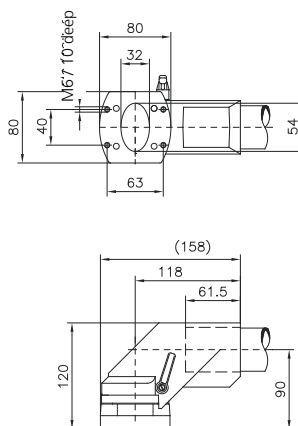



**Components**

**Console flange**



Order No.      Execution

**49.49 76 00**      Aluminium incl. screws and seal, fixed inclination 30°

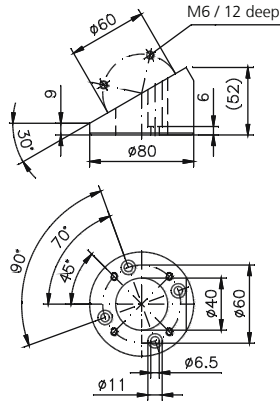

**Adapter flange**



Order No.      Execution

**49.49 79 00**      Cast steel part for mounting between wall and wall hinge for free cable routing, cable opening top or bottom as required.

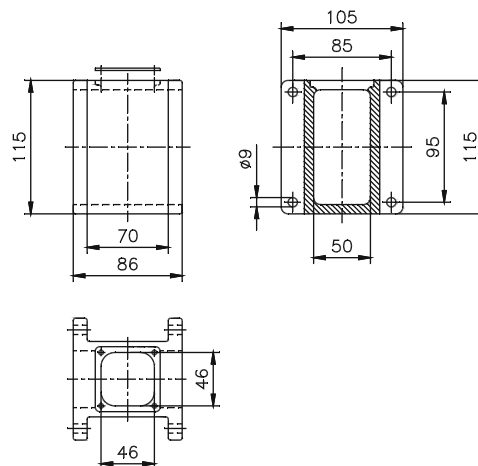

**Inclining adapter**



Order No.      Execution

**49.49 80 00**      Diecast aluminium part with bellow and seal, inclination can be adjusted to any angle between 0° and 45°.

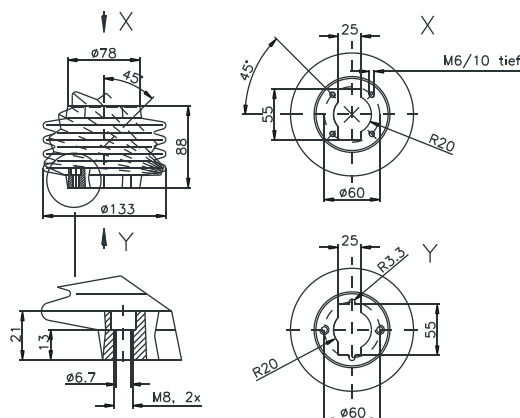



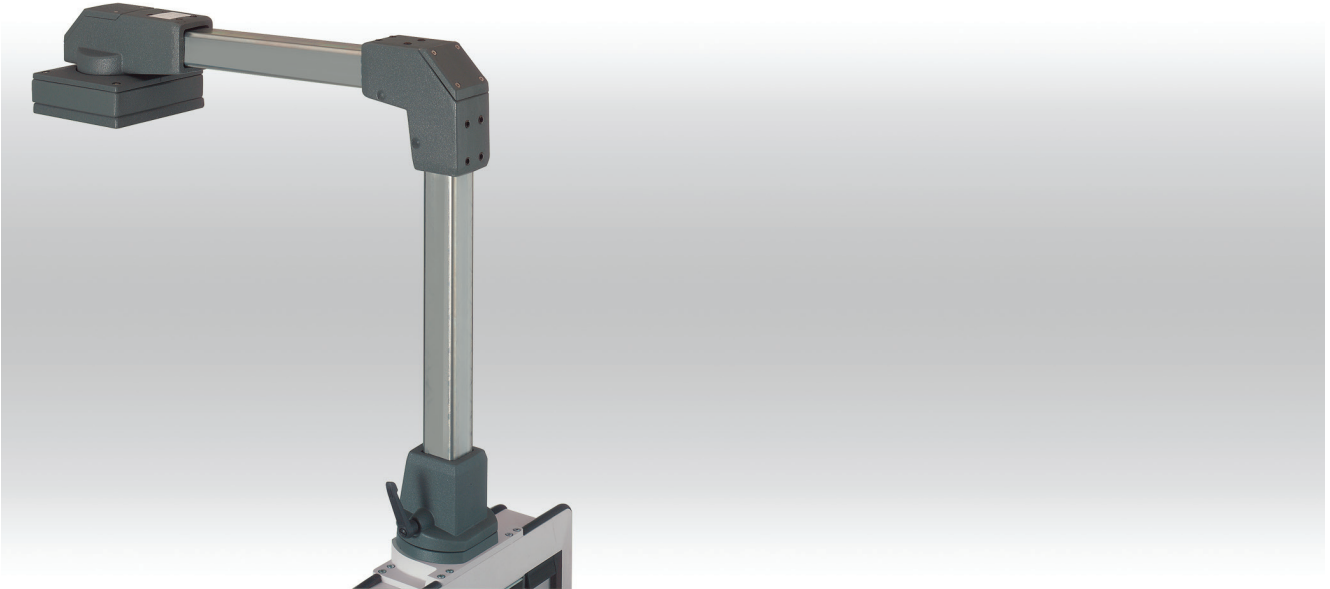

- + Robust industrial square tube suspension system
- + Modular construction for individual components
- + High loading capacity, large extension

#### Included in delivery

Individual system components incl.  
assembly material

### Technical data

<b>Material</b>	Connecting tube: square steel tube similar DIN EN 10305-5 Wall thickness 5 mm Components: DIN EN 1706 EN AC-ALSi 12 (Fe)
<b>Painting</b>	Powder coating
<b>Colour</b>	Tube: galvanized Components: RAL 7043, traffic grey B, Special colour on request
<b>Ingress protection</b>	IP 65 to EN 60529



**Product range**

	GT 50/2		GT 60/2		GT 80/2	
Type	Order No.	Weight (g)	Order No.	Weight (g)	Order No.	Weight (g)
Top-mounted joint	<b>49.51 66 00</b>	12000	<b>49.61 66 00</b>	16000	<b>49.81 66 00</b>	21000
Foot stand, cast steel	<b>49.51 74 00</b>	2880	<b>49.61 74 00</b>	3650	<b>49.81 74 00</b>	5440
Wall hinge	<b>49.51 70 00</b>	5460	<b>49.61 70 00</b>	7780	<b>49.81 70 00</b>	11000
Adapter flange	<b>49.51 79 00</b>	2800	<b>49.61 79 00</b>	3750	<b>49.81 79 00</b>	6020
Intermediate joint	<b>49.51 67 00</b>	5940	<b>49.61 67 00</b>	8370	<b>49.81 67 00</b>	12000
Angle, cast steel	<b>49.51 80 00</b>	4180	<b>49.61 80 00</b>	5630	<b>49.81 80 00</b>	7920
Flange angle coupling	<b>49.51 78 00</b>	2410	<b>49.61 78 00</b>	3240	<b>49.81 78 00</b>	4610
Coupling					<b>49.81 73 00</b>	2680
Flange coupling	<b>49.51 77 00</b>	1890	<b>49.61 77 00</b>	2600	<b>49.81 77 00</b>	4560
Console adapter 30°	<b>49.51 76 00</b>	901	<b>49.61 76 00</b>	1270	<b>49.81 76 00</b>	2240
Signal fitting	<b>49.51 80 10</b>	211	<b>49.61 80 10</b>	267	<b>49.81 80 10</b>	339
Adapter plate GTK on GT 80/2; GT 60/2					<b>49.81 10 00</b>	829
Column	<b>49.51 00 04</b>		<b>49.61 00 04</b>		on request	

Connecting tube	GT 50/2		GT 60/2		GT 80/2	
	Order No.	Weight (g)	Order No.	Weight (g)	Order No.	Weight (g)
Standard length: 0,5 m	<b>10.09 42 20</b>	3330	<b>10.09 42 23</b>	4120	<b>10.09 42 27</b>	5690
Standard length: 1 m	<b>10.09 42 21</b>	6660	<b>10.09 42 24</b>	8230	<b>10.09 42 28</b>	11000
Standard length: 2 m	<b>10.09 42 22</b>	13000	<b>10.09 42 25</b>	16000	<b>10.09 42 29</b>	23000
Standard length: 3 m	<b>10.09 42 42</b>	20000	<b>10.09 42 26</b>	25000	<b>10.09 42 30</b>	34000
Variable length (please specify)	<b>10.09 41 56</b>		<b>10.09 41 57</b>		<b>10.09 41 59</b>	

**Load diagram**

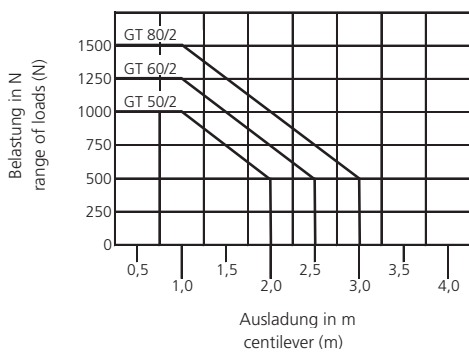

Note: the vertical length of the profile is responsible for the load of the complete suspension system (lever arm!).  
 Further information for this on request. The values in the above load diagram are guilty to an execution hanging or standing.  
 The declarations of weight are a summary from installation weight, Commander and all components and tubes between Commander and angle.

System structure

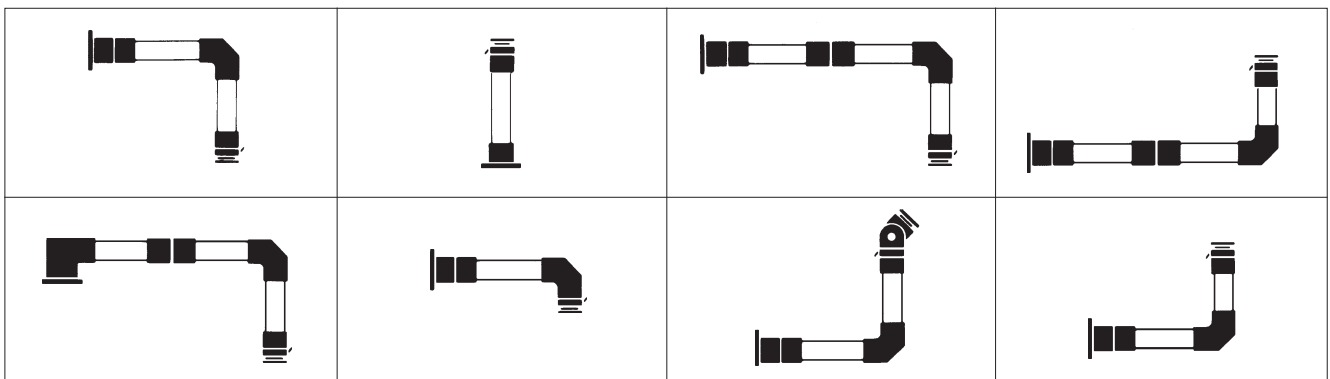

**Components**

**Top-mounted joint**



Swivelling range 310°, can be limited from between 0° to 270°, swivel force can be adjusted via bearing screw

Type	Order No.	Weight (g)	A	B	C	D	E	F	G	H	J	K	L
50/2	<b>49.51 66 00</b>	12000	251	160	95	180	50	39,5	50	151	35	150	116
60/2	<b>49.61 66 00</b>	16000	278	179,5	110	195	58	44,5	60	171	38	165	125
80/2	<b>49.81 66 00</b>	21000	306	197,5	125	215	76	54,5	80	206	46	185	145

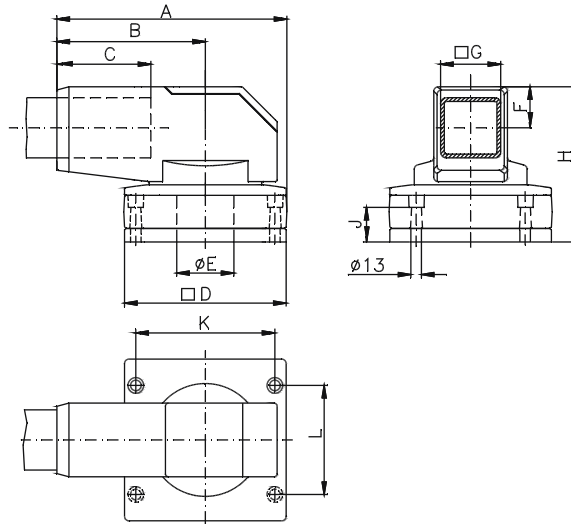

**Foot stand**



Cast steel element for floor mounting or wall mounting, can be adjusted

Type	Order No.	Weight (g)	A	B	C	D	E	F	G	H	K	L	M
50/2	<b>49.51 74 00</b>	2880	128	90	80	12	20,5	19,5	40	100	57	71	12
60/2	<b>49.61 74 00</b>	3650	138	100	90	14	25,5	24,5	50	110	63	77	12
80/2	<b>49.81 74 00</b>	5440	162	115	105	16	35,5	34,5	80	130	74,5	90,5	14

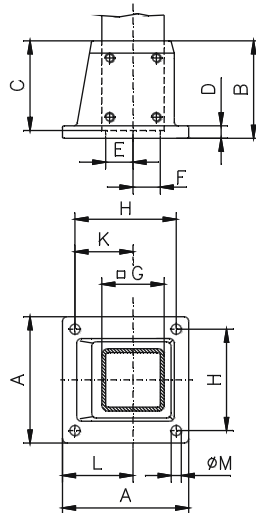

# GT50/2 GT60/2 GT80/2

## Components

### Wall hinge



Type	Order No.	Weight (g)	A	B	C	D	E	F	G	H	J	K	L	M	N	O	P	R	S
50/2	<b>49.51 70 00</b>	5460	140	90	95	12	132	125	40	50	58	164	107	50	27,5	48	35	11	12
60/2	<b>49.61 70 00</b>	7780	162	102	110	15	140	145	45	60	62	176	115	60	32,5	57	44,5	15	12
80/2	<b>49.81 70 00</b>	11000	185	137	125	20	161	178	56	80	75	210	138	80	43,5	68	67	25	14

Swivelling range 180°, can be limited to stepped degrees with stops, swivel force can be adjusted via bearing screw.

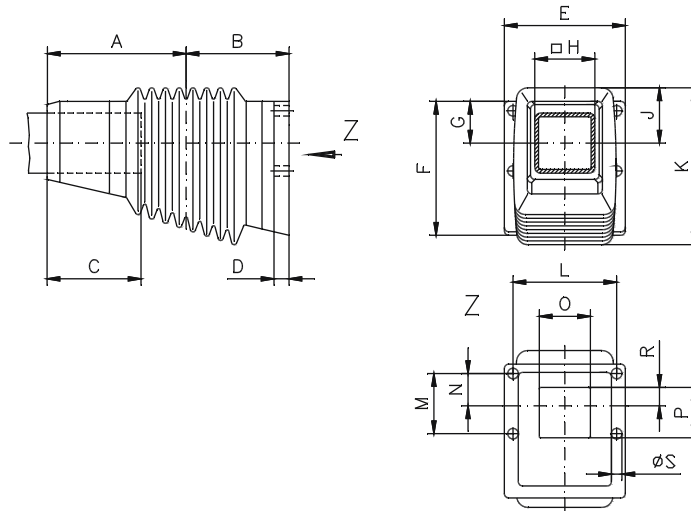

### Adapter flange for wall hinge



Type	Order No.	Weight (g)	A	B	C	D	E	F	G	H	J	K	L
50/2	<b>49.51 79 00</b>	2800	66	132	125	46	57	89	100	107	12	0	12
60/2	<b>49.61 79 00</b>	3750	72	140	145	52	65	109	120	115	15	0	12
80/2	<b>49.81 79 00</b>	6020	82	161	178	62	86	142	153	138	20	7	15

Cast steel adapter for mounting between wall hinge and mounting surface

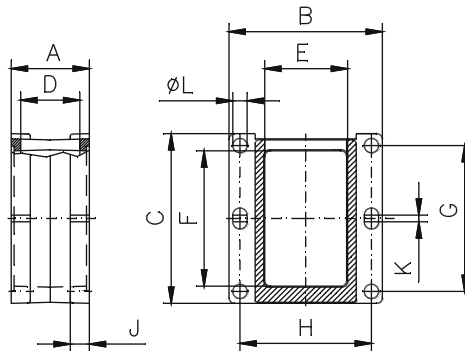

### Intermediate joint



Type	Order No.	Weight (g)	A	B	C	D	E	F
50/2	<b>49.51 67 00</b>	5940	140	95	107	58	152	50
60/2	<b>49.61 67 00</b>	8370	162	110	114	62	162	60
80/2	<b>49.81 67 00</b>	12000	185	125	136	75	190	80

Swivelling range 180°, can be limited to stepped degrees with stops, swivel force can be adjusted via bearing screw.

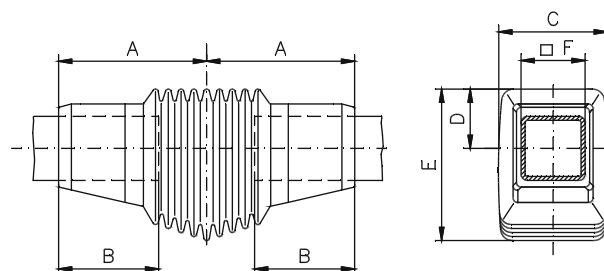

**Components**

**Flange coupling**



Swivelling range 325° can be stopped at any point with clamping lever, stops can limit movement in 25° steps

Type	Order No.	Weight (g)	A	B	C	D	E	F	G	H	J	K	L	M
50/2	<b>49.51 77 00</b>	1890	110	107	53,5	48	55	116	131	50	57	77	-	-
60/2	<b>49.61 77 00</b>	2600	124	117	59,5	58	65	136,5	141	60	57	77	-	-
80/2	<b>49.81 77 00</b>	4560	151	141	70,5	80	87	166	175	80	84	104	60	130

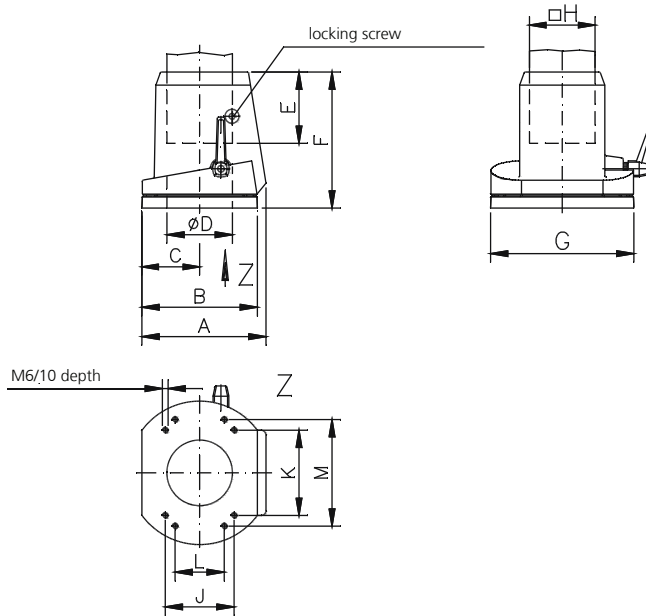

**Flange angle coupling**



Swivelling range 325° can be stopped at any point with clamping lever, stops can limit movement in 25° steps. Angle flange coupling cannot be used as top-mounted joint!

Type	Order No.	Weight (g)	A	B	C	D	E	F	G	H	J	K	L	M	N
50/2	<b>49.51 78 00</b>	2410	187,5	134	80	107	131	48	50	117,5	39,5	77	57	-	-
60/2	<b>49.61 78 00</b>	3240	216,5	158	90	117	141	58	60	130,5	42,5	77	57	-	-
80/2	<b>49.81 78 00</b>	4610	276,5	206	107	141	175	80	80	160	55,5	104	84	130	60

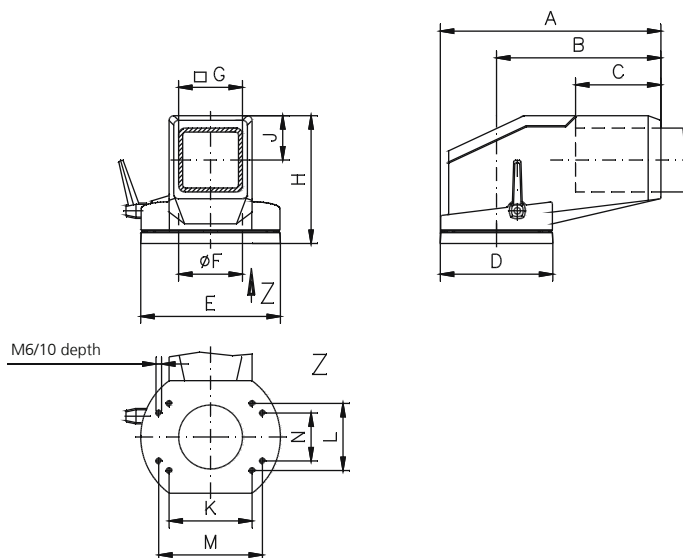

**Components**

**Angle**



Cast steel angle joint 90°

Type	Order No.	Weight (g)	A	B	C	D	E
50/2	<b>49.51 80 00</b>	4180	154	115	80	74	50
60/2	<b>49.61 80 00</b>	5630	172	128	90	84	60
80/2	<b>49.81 80 00</b>	7920	210	157	105	98	80

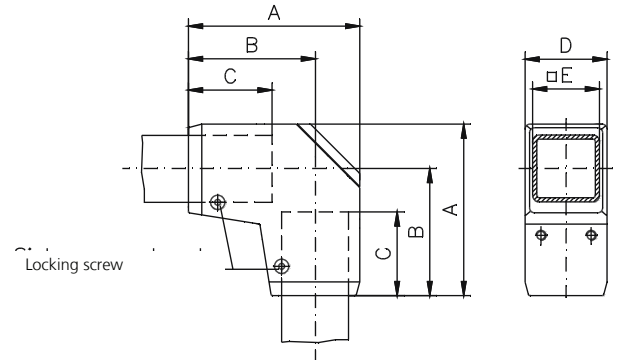

**Signal fitting**



Cast aluminium part for mounting indicator lights on the angle.

Type	Order No.	Weight (g)	A	B	C	D	E	F
50/2	<b>49.51 80 10</b>	211	74	60	36	54	29	38
60/2	<b>49.61 80 10</b>	267	84	65	40	62	32	43
80/2	<b>49.81 80 10</b>	339	98	76	54	82	42	54

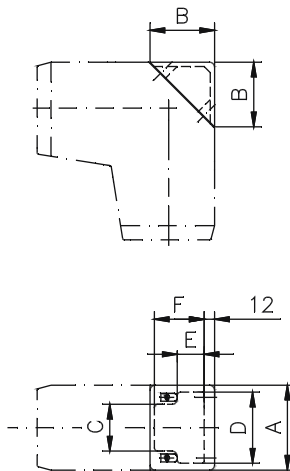

**Adapter GTK on GT 80/2; GT 60/2**



Order No.

**49.81 10 00**

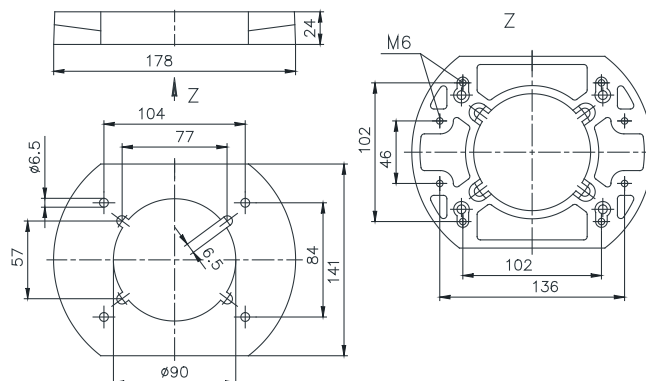



**Components**

**Coupling**



Type	Order No.	Weight (g)	A	B	C	D	E	F	G	H	K	L	M	N	O
80/2	<b>49.81 73 00</b>	2680	104	80	104	145,5	115	M90 x 2	80	49	34	90,8	91	10,2	111

Swivelling range 300° can be stopped at any point with clamping lever.

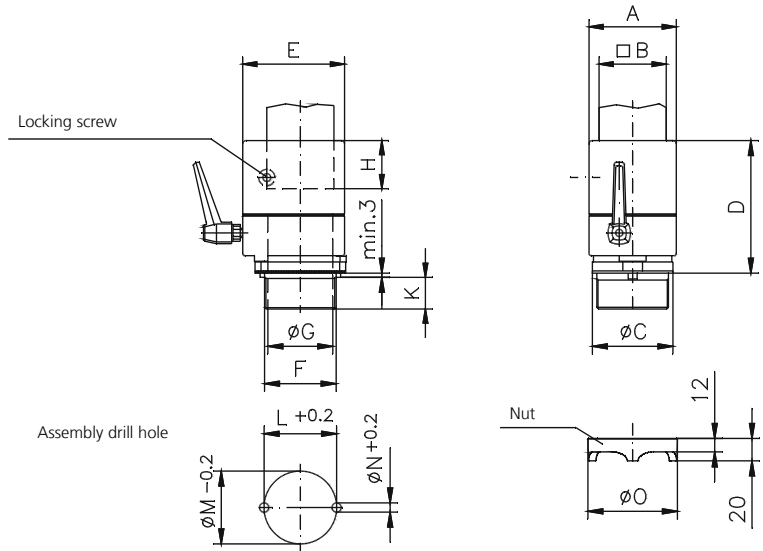

**Column**



Sheet steel, painted, individual length including adapter plate for top mounted joint. At the base flange outlet max. length 2 m.

Order No.		A	B
<b>49.51 00 04</b>	GT 50/2 (please specify complete length)	116	150
<b>49.61 00 04</b>	GT 60/2 (please specify complete length)	125	165
on request	GT 80/2		

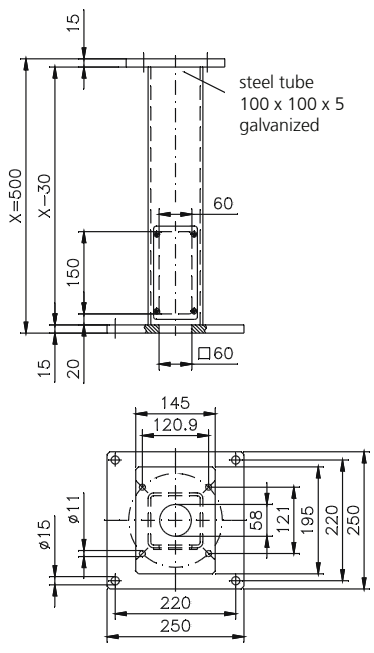

**Components**

**Console adapter**



Cast aluminium part with fixed 30° inclination for assembly between enclosure and flange coupling  
GT 50/2, GT 60/2 and GT 80/2.

Type	Order No.	Weight (g)	A	B	C	D	E	F	G	H	K	L	M
50/2	<b>49.51 76 00</b>	901	107	131	71	92	57	77	-	-	14	-	50
60/2	<b>49.61 76 00</b>	1270	117	141	76	102	57	77	-	-	18	-	60
80/2	<b>49.81 76 00</b>	2240	141	175	89	128	84	104	60	130	17	35	80

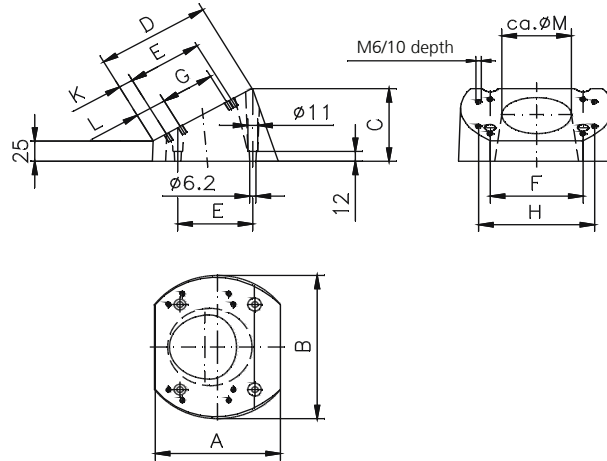

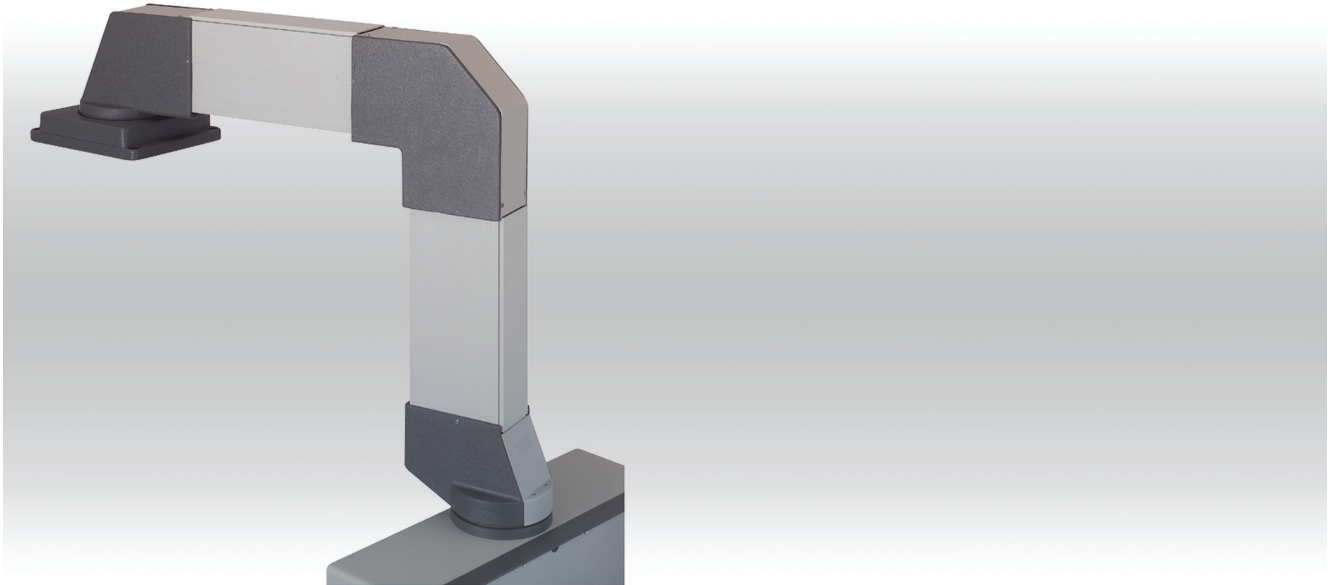

- + Industrial square suspension system with free accessible cable channel
- + Modular construction with free accessible cable duct
- + Floor, top-mounting or wall options

**Included in delivery**

Individual system components incl. cable duct covering and assembly materials

**Technical data**

<b>Material</b>	Connecting tube: Square ST 37 similar DIN EN 10305-5 wall thickness 5 mm or 8 mm Components: spheroidal graphite cast iron and/or cast aluminium Cable duct / cover: aluminium extruded profile Bearing: ball bearing Bellow: textile fabric
<b>Painting</b>	Powder coating
<b>Colour</b>	Cable duct / cover: RAL 7035, light grey Components: RAL 7043, traffic grey B, Special colour on request
<b>Ingress protection</b>	with top-mounted flange IP 54 to EN 60529



# GTK 80

## Product range

Type	Order No.	Weight (g)
Top-mounted joint	<b>49.90 66 01</b>	17000
Foot stand / wall flange	<b>49.90 74 01</b>	6960
Wall hinge	<b>49.90 70 01</b>	19000
Intermediate joint	<b>49.90 67 01</b>	16000
Angle (FH) cast steel	<b>49.90 71 11</b>	11000
Angle (AS) Aluminium	<b>49.90 71 20</b>	3470
Angle coupling	<b>49.90 75 01</b>	5770
Coupling	<b>49.90 73 01</b>	5250
Top-mounted flange type A	<b>49.90 00 30</b>	1330
Top-mounted flange type B	<b>49.90 00 20</b>	1150

	Cable duct (standard length to fit relevant suspension tube)	Weight (g)	Suspension tube 80 x 80 x 5 mm	Weight (g)	Suspension tube 80 x 80 x 8 mm	Weight (g)
Standard length: 0,5 m	<b>10.09 42 35</b>	1350	<b>10.09 42 27</b>	5800	<b>10.09 42 31</b>	8400
Standard length: 1 m	<b>10.09 42 36</b>	2920	<b>10.09 42 28</b>	11600	<b>10.09 42 32</b>	17000
Standard length: 2 m	<b>10.09 42 37</b>	6060	<b>10.09 42 29</b>	23200	<b>10.09 42 33</b>	34000
Standard length: 3 m	<b>10.09 42 38</b>	9200	<b>10.09 42 30</b>	34800	<b>10.09 42 34</b>	50000
Variable length (please specify)	<b>10.09 41 65*</b>		<b>10.09 41 59</b>		<b>10.09 41 68</b>	

\* The cable duct needs to be 175 mm shorter than the suspension tube length!

## Load diagram

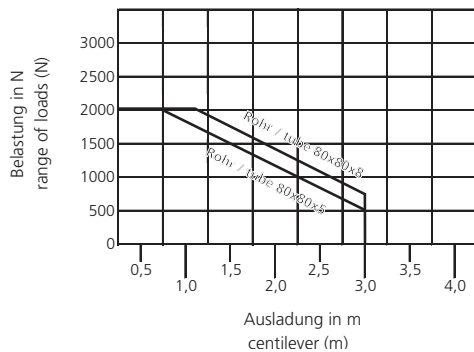

Note: the vertical length of the profile is responsible for the load of the complete suspension system (lever arm!). Further information for this on request. The values in the above load diagram are guilty to an execution hanging or standing.

The declarations of weight are a summary from installation weight, Commander and all components and tubes between Commander and angle.

## System structure

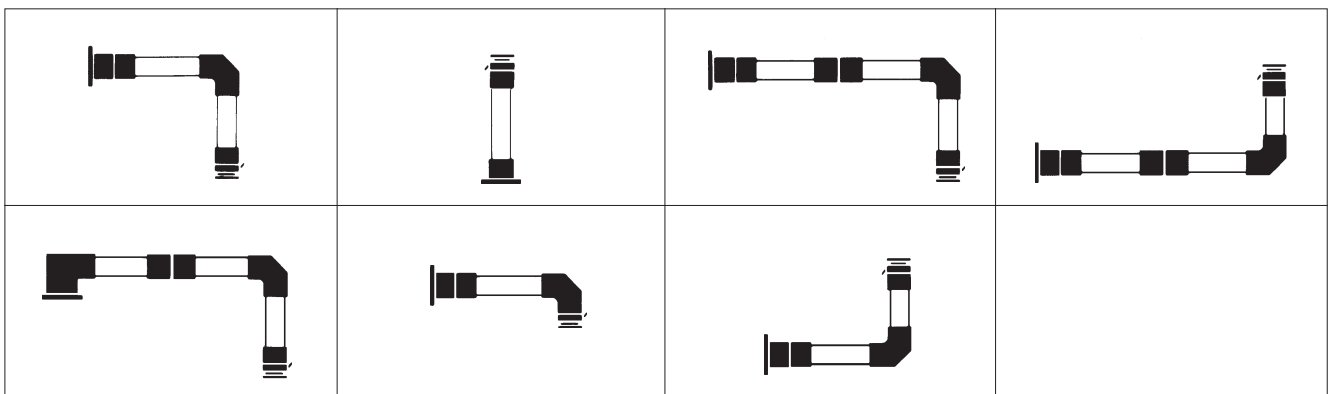

Components

Top-mounted joint



Order No.	Execution
<b>49.90 66 01</b>	Cast iron. Swivelling range 360°

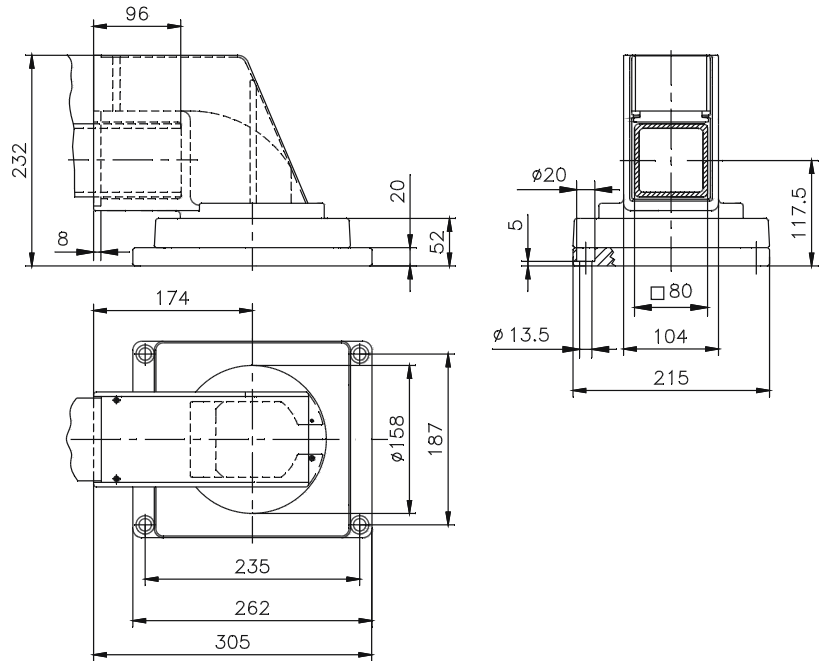

Foot stand / wall flange

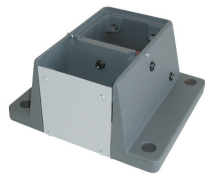

Order No.	Execution
<b>49.90 74 01</b>	Cast iron

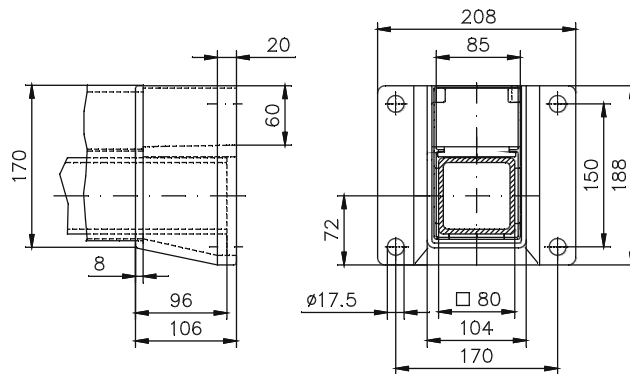



**Components**

**Angle (A5)**



Order No.  
**49.90 71 20**

Execution  
Cast aluminium. 90°-angle for vertical construction from the bottom up with minimal bending load

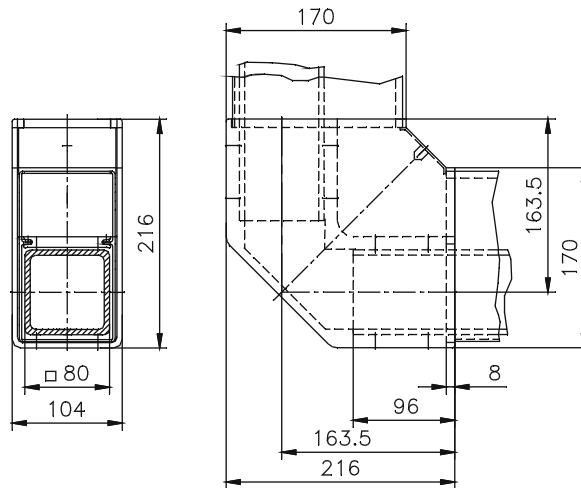

**Coupling**



Order No.  
**49.90 73 01**

Execution  
Cast aluminium. Swivelling range 320°  
Lockable with clamping lever.

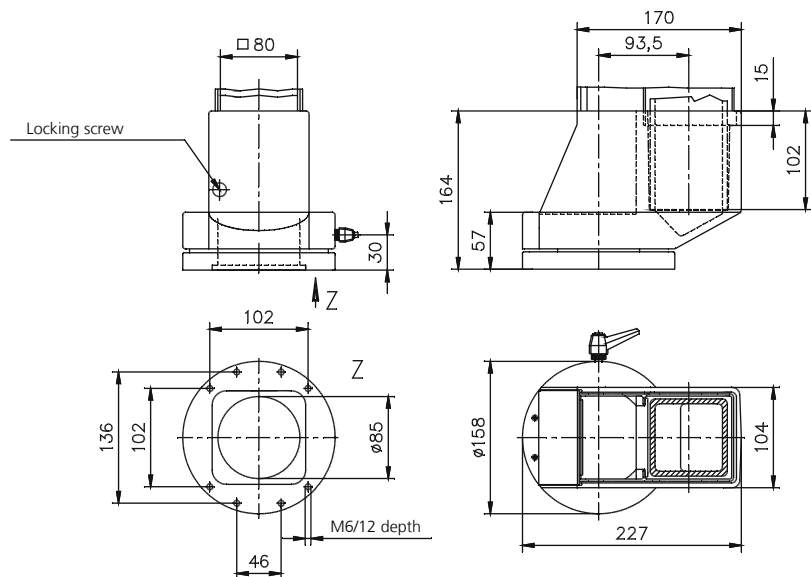

Components

Angle coupling



Order No.	Execution
<b>49.90 75 01</b>	Cast aluminium. Swivelling range 320°. Lockable with clamping lever.

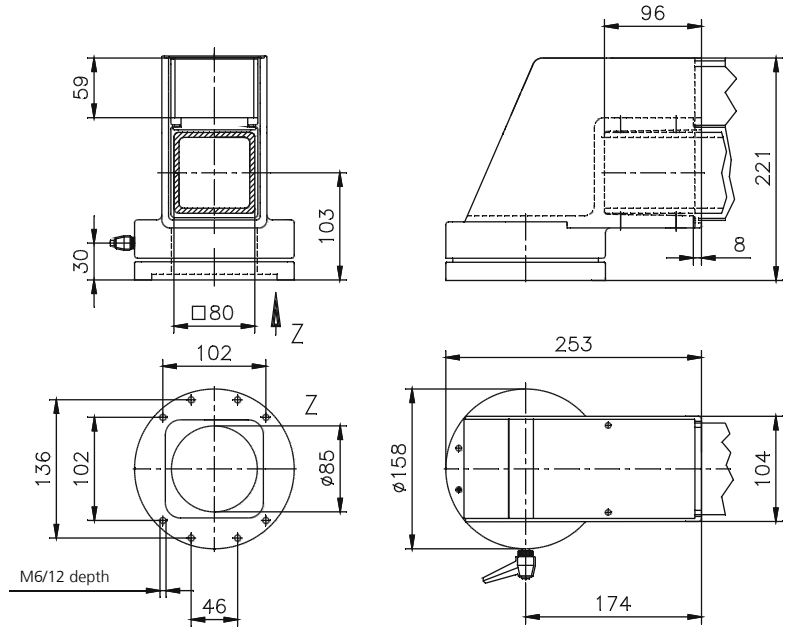

Top-mounted flange



Order No.	Execution
<b>49.90 00 30</b>	Type A: Cast aluminium Large area mounting on enclosure for maximum 3 ready-made leads with diameters from 7 to 26 mm. Open cable entry.
<b>49.90 00 20</b>	Type B: Cast aluminium Large area mounting on enclosure for a large number of ready-made leads. Sealed with special cable glands or threaded cable connectors. Open cable entry.

Fitted in combination with coupling or angle coupling to maintain compliance with enclosure rating IP 65 at transition to control panel.

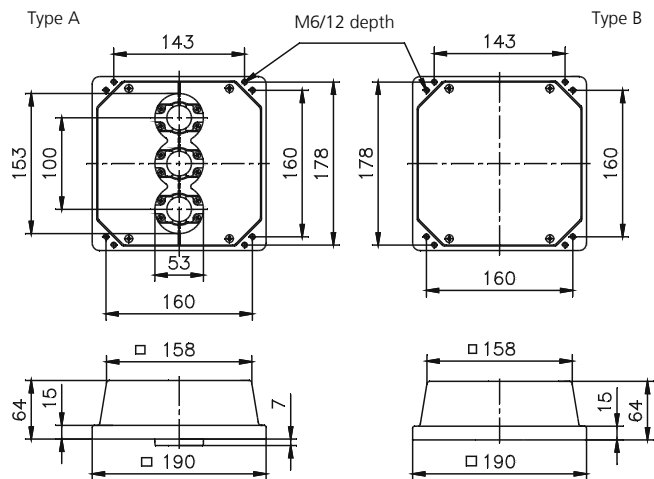





- + Mobile stand system for control components
- + Optional fixed or manual adjustable versions
- + Version with 2 or 4 roller system

### Technische Daten

Material:

Foot: sheet steel

Profile: DIN EN 573 EN AW-ALMgSi

Painting:

Powder coating

Colour:

Profile: RAL 7035, light grey

Foot: RAL 7021, black grey

Max. static load:

35 kg (Moterm 1 and 2)

80 kg (Moterm 4 and 5)

#### Included in delivery

Moterm with mounted inclination adjuster and adapter plate for commander systems (please order adapter plate separately)



# Moterm I

## Product range

Order No.	Type	Height	Description	Weight
50.01 01 01	Moterm 1	1000 mm	fixed version, 2 rollers	23
50.01 01 02	Moterm 2	750 mm to 1000 mm	manually adjustable, 2 rollers	23
50.01 01 04	Moterm 4	980 mm	fixed version, 4 rollers	25
50.01 01 05	Moterm 5	730 mm to 1000 mm	manually adjustable, 4 rollers	26,5

## Zubehör

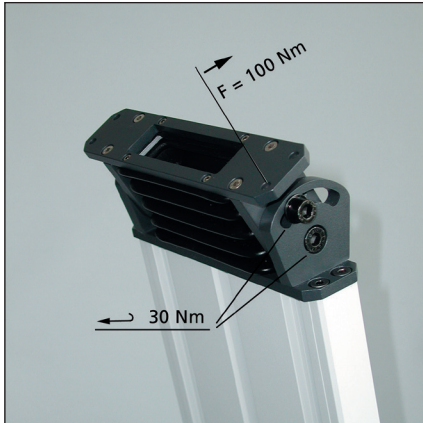

Universal adapter plate on moterm

Adapter plate for connection to the control enclosure

Order No.	Type
50.01 02 03	Adapter plate SL 2000 profile 1
50.01 02 04	Adapter plate SL 2000 profile 2
50.01 02 05	Adapter plate SL 2000 profile 3
50.01 02 06	Adapter plate SL 3000 profile 1
50.01 02 07	Adapter plate SL 3000 profile 2 to 4
50.01 02 08	Adapter plate SL 3000 console version
50.01 02 09	Adapter plate universal (see drawing)
50.01 02 10	Adapter plate Beckhoff CP 7032
50.01 02 11	Adapter plate ComTronic
50.01 02 12	Adapter plate SL 3000 profile 4 (direct mounting)
50.01 02 14	Adapter plate SL 4000 profile 1 - 3
50.01 02 15	Adapter plate SL 4000 console version

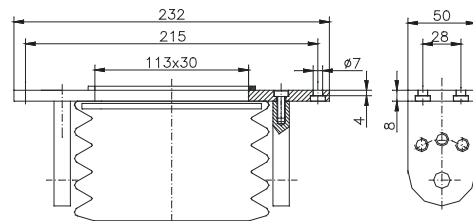

## Load specification Moterm 4 and 5

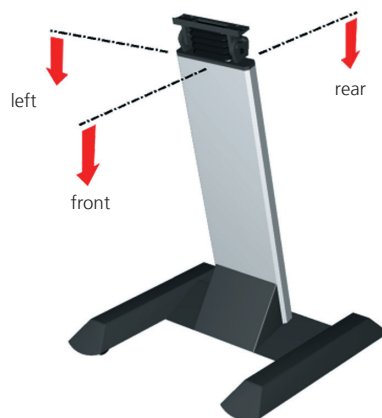

Max. static load capacity: 80 kg

The following table gives details for one-sided or uneven loading of Moterm 4 and 5. Stability on an even surface is guaranteed if these values are maintained.

### Load case

front		rear		left/right	
Load	Working range	Load	Working range	Load	Working range
48 kg	350 mm	80 kg	400 mm	56 kg	430 mm
43 kg	390 mm	61 kg	450 mm	35 kg	530 mm
33 kg	430 mm	45 kg	500 mm	17,8 kg	730 mm
28 kg	450 mm				

The data relates to a structure height of 960 mm and 0° inclination adjustment.

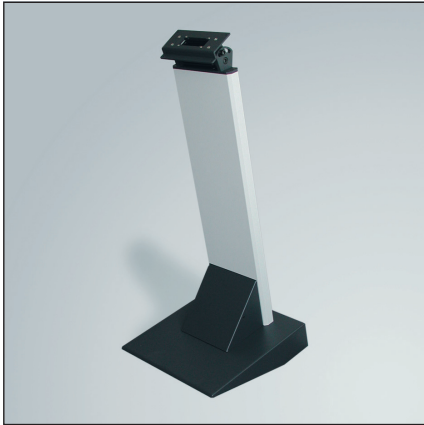

**Moterm 1**  
Fixed version

Order No. 50.01 01 01

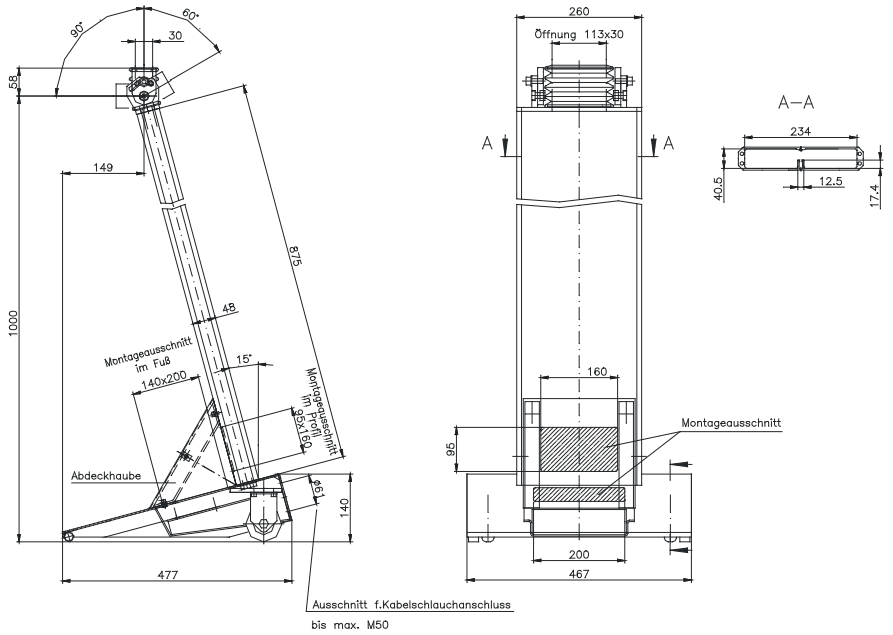

**Moterm 2**  
Manually adjustable

Order No. 50.01 01 02

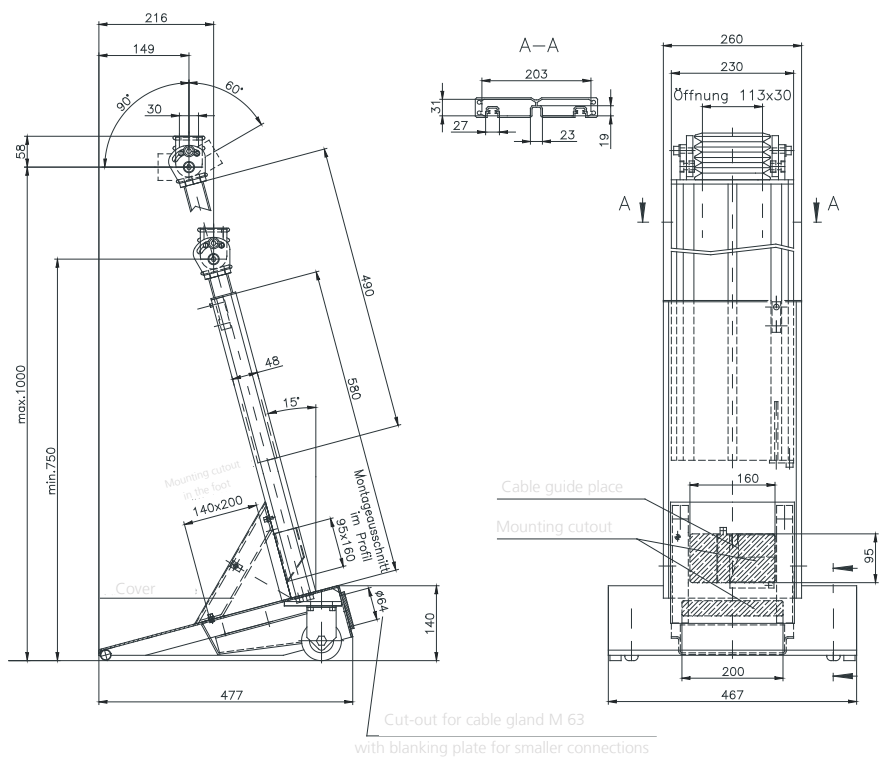





- + Mobile stand system for control components
- + Fixed or height-adjustable version with pneumatic spring
- + Version with 4 rollers or with foot stand
- + Optionally foot stand for anchoring

**Included in delivery**

Moterm with integrated tilt adjustment for adapter plate for control systems  
(Please order adapter plate separately)

**Technical data**

<b>Material</b>	Base and stand profile: Aluminium profile system; DIN EN 573 EN AW-AMgSi
<b>Colour</b>	Stand profile: plain anodized, optional powder-coated Base: RAL 9005, jet black
<b>Maximum static load</b>	80 kg



# Moterm II

## Product range

### Moterm x11



Version with levelling feet to adjust for floor irregularities – as a stand system  
Version with fixed height (966 mm), other height or base dimensions on request

Order No.	Type	Height	Execution	Load
50.01 03 11	Moterm 311	1059 mm	fixed height, with foot stand	8 - 80 kg
50.01 09 11	Moterm 911	customized	fixed height, with foot stand	customized

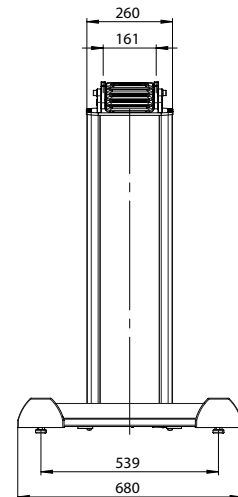
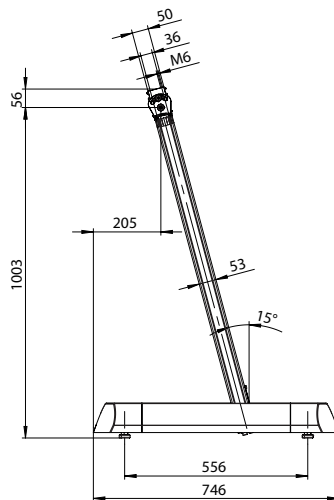

### Moterm x12



Version with levelling feet to adjust for floor irregularities – as a stand system  
Version with pneumatic spring and release mechanism  
Height can be adjusted from 750 mm to 1000 mm  
for load ranges from 8 to 50 kg; other load values on request

Order No.	Type	Height	Execution	Load
50.01 03 12	Moterm 312	886 mm to 1128 mm	manually adjustable, with food stand	8 - 15 kg
50.01 04 12	Moterm 412	886 mm to 1128 mm	manually adjustable, with food stand	16 - 22 kg
50.01 05 12	Moterm 512	886 mm to 1128 mm	manually adjustable, with food stand	23 - 30 kg
50.01 06 12	Moterm 612	886 mm to 1128 mm	manually adjustable, with food stand	31 - 40 kg
50.01 07 12	Moterm 712	886 mm to 1128 mm	manually adjustable, with food stand	41 - 50 kg
50.01 09 12	Moterm 912	886 mm to 1128 mm	manually adjustable, with food stand	customized

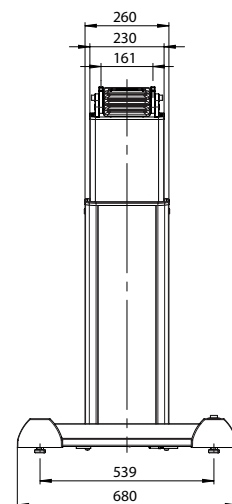
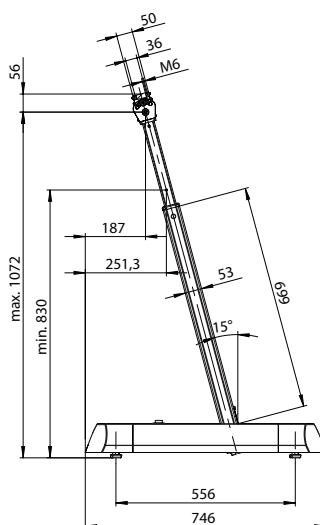

Technical details

Moterm x14



Version with 4 rollers, 2 movable and 2 locking rollers  
 Version with fixed height (984 mm), other height or base dimensions on request

Order No.	Type	Height	Execution	Load
50.01 03 14	Moterm 314	1081 mm	fixed height, 4 rollers	8 - 80 kg
50.01 09 14	Moterm 914	variable Execution	fixed height, 4 rollers	customized

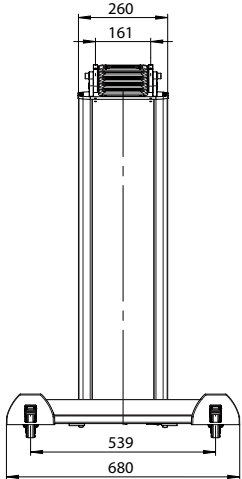
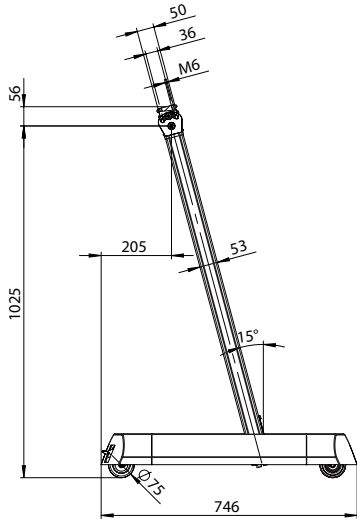

Moterm x15



Version with 4 rollers, 2 movable and 2 locking rollers, with pneumatic spring and release mechanism  
 Height can be adjusted from 750 mm to 1000 mm for load ranges from 8 to 50 kg; other load values on request

Order No.	Type	Height	Execution	Load
50.01 03 15	Moterm 315	886 mm to 1128 mm	manually adjustable, 4 rollers	8 - 15 kg
50.01 04 15	Moterm 415	886 mm to 1128 mm	manually adjustable, 4 rollers	16 - 22 kg
50.01 05 15	Moterm 515	886 mm to 1128 mm	manually adjustable, 4 rollers	23 - 30 kg
50.01 06 15	Moterm 615	886 mm to 1128 mm	manually adjustable, 4 rollers	31 - 40 kg
50.01 07 15	Moterm 715	886 mm to 1128 mm	manually adjustable, 4 rollers	41 - 50 kg
50.01 09 15	Moterm 915	886 mm to 1128 mm	manually adjustable, 4 rollers	customized

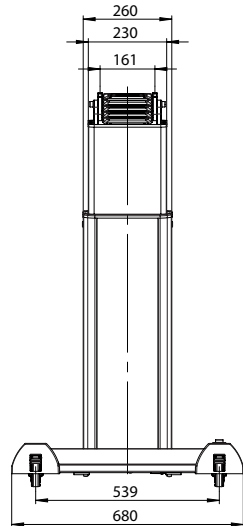
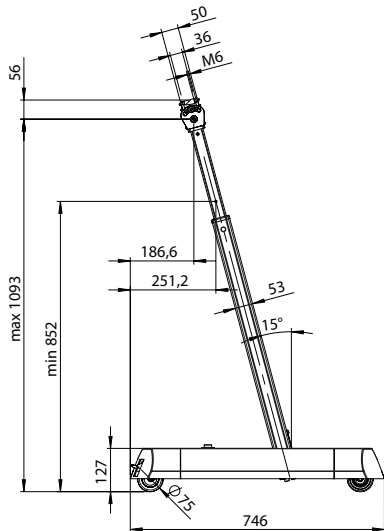

## Accessories

### Adapter plate for connecting to the control enclosure

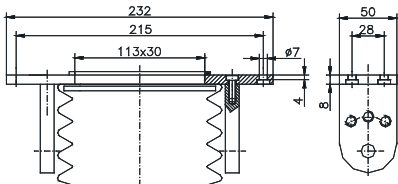

Order No.	Type
50.01 02 03	Adapter plate SL 2000 Profile 1
50.01 02 04	Adapter plate SL 2000 Profile 2
50.01 02 05	Adapter plate SL 2000 Profile 3
50.01 02 06	Adapter plate SL 3000 Profile 1
50.01 02 07	Adapter plate SL 3000 Profile 2 to 4
50.01 02 08	Adapter plate SL 3000 console version
50.01 02 09	Adapter plate universal (s. drawing)
50.01 02 10	Adapter plate Beckhoff CP 7032
50.01 02 11	Adapter plate ComTronic
50.01 02 12	Adapter plate SL 3000 Profile 4 (direct installation)
50.01 02 14	Adapter plate SL 4000 Profile 1 - 3
50.01 02 15	Adapter plate SL 4000 console version

### Feet for anchoring



Order No.	Execution
50.00 01 01	Set = 2 pcs

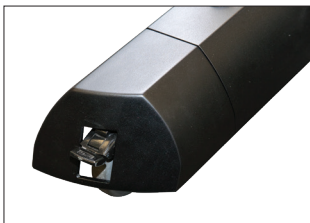

Locking system for version with rollers



Simple adjustment option for height adjustment

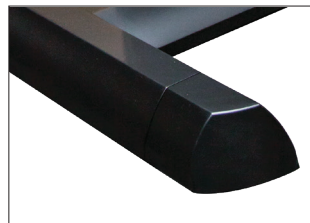

Floor attachment with levelling unit (optionally für anchoring)



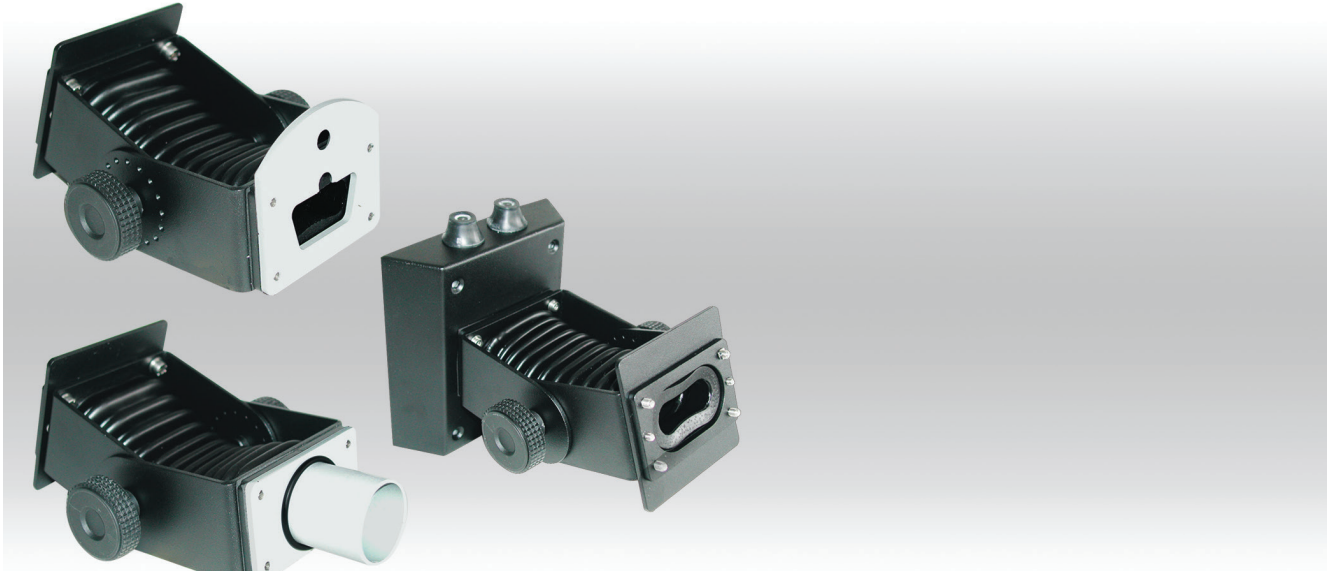

- + Inclining adapter for individual connections between enclosure and ROSE suspension systems or for wall mounting
- + Simply handling by open design
- + Stepped adjuster allows inclination to suit your application

### Included in delivery

Inclining adapter, pre-assembled flange plates, sealings and mounting material

## Technical data

<b>Material</b>	Sheet steel 2,5 mm Bellow: PVC
<b>Colour</b>	Powder coating, RAL 9005, jet black Bellow: RAL 9005, jet black
<b>Ingress protection</b>	IP 54





## Technical details

### Inclining adapter for GT 48/2 (tube)



Order No.

Execution

**50.02 00 02**

Sheet steel parts for inclined mounting of a Limanda or other enclosure. Mounted directly onto the circular tube of the GT 48/2 rack system. Fastened to the tube via olive rings (the thread in the circular tube is attached afterwards). Enclosure rating IP 54 once assembled. Dust and damp protection by bellow (black). Swivelling range 180° in 22.5° steps, adjusted with knurled screw.

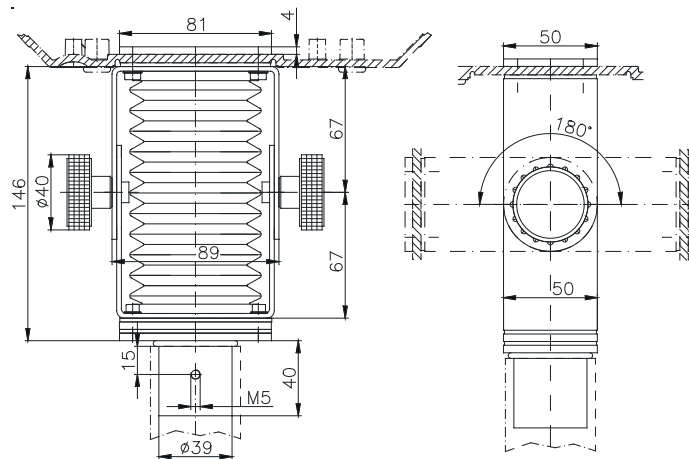

### Inclining adapter for GTK electronic



Order No.

Execution

**50.02 00 03**

Sheet steel parts for inclined mounting of a Limanda or other enclosure. Mounted directly onto the connecting tube of the GTK electronic rack system. Flange mounted onto tube with self-tapping screws. Enclosure rating IP 54 once assembled. Dust and damp protection by bellow (black). Swivelling range 180° in 22.5° steps, adjusted with knurled screw.

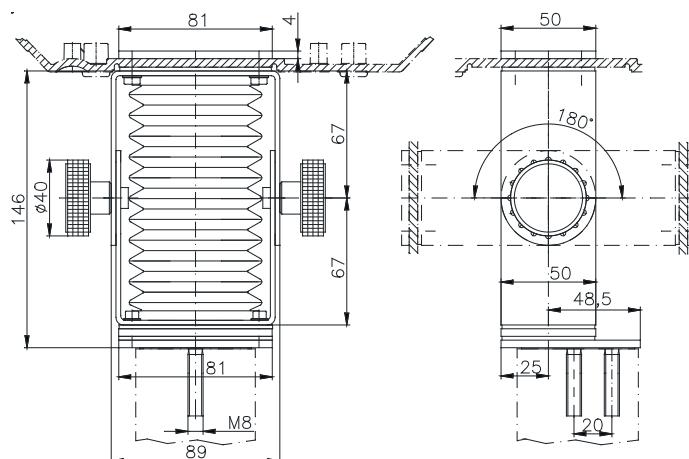

# Inclining adapter

## Technical details

### Inclining adapter for GT 48/2 or GTK electronic



Order No.	Execution
<b>50.02 00 04</b>	Sheet steel parts for inclined mounting of a Limanda or other enclosure. Attached to the GT 48/2 or GTK electronic rack system flange coupling with flange plate. Enclosure rating IP 54 once assembled. Dust and damp protection by bellow (black). Swivelling range 180° in 22.5° steps, adjusted with knurled screw.

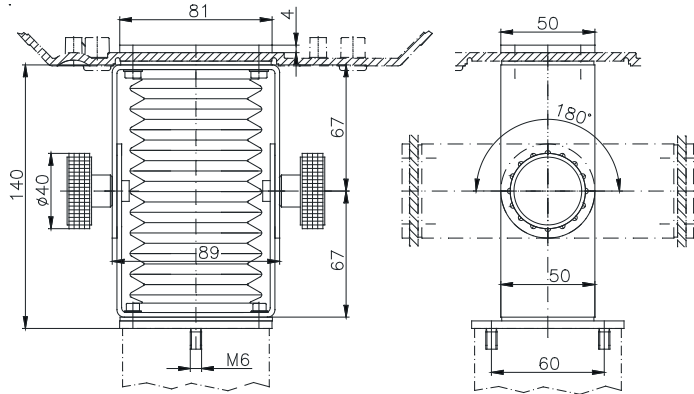

### Inclining adapter stainless steel



Order No.	Execution
<b>50.02 10 01</b>	parts for inclined mounting of a Limanda or other enclosure. Attached to the GT 48/2 or GTK electronic rack system flange coupling with flange plate. Enclosure rating IP 54 once assembled. Dust and damp protection by bellow (black). Swivelling range 180° in 22.5° steps, adjusted with knurled screw.

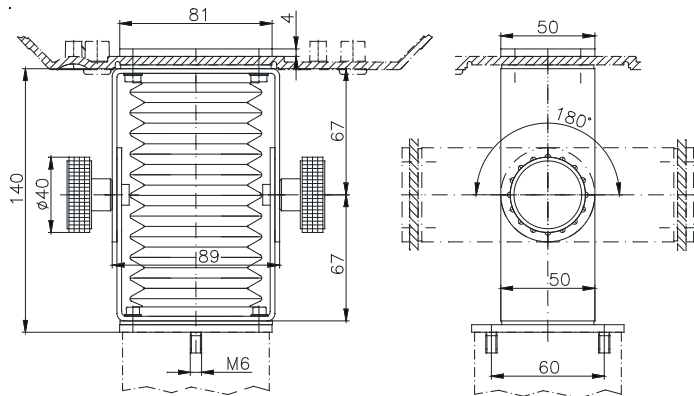

### Inclining adjustment



Order No.	Execution
<b>50.02 01 01</b>	Continuously variable inclining system (+/- 75°) for Commander systems. System consisting in aluminium elements with bellow. Scope of supply: base unit without adaptation plate

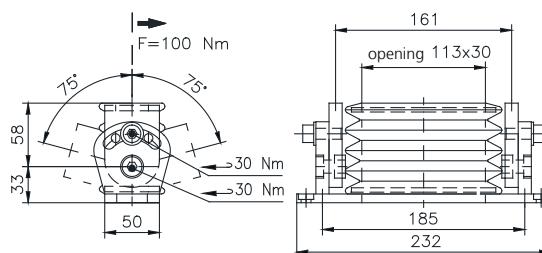



- + Polyamide hand held enclosures for data acquisition, MCR and automation engineering
- + For installations and command devices mobile and stationary applicable
- + Variable mounting depths

**Included in delivery**

Clam shell enclosure with top and base, each with fixing domes incl. seals and border profile, 3 cover flaps for interface garages, screws and fixing materials for front panel mounting.

**Technical data**

<b>Material</b>	Enclosure: Polyamide Border profile: NBR, black
<b>Colour</b>	RAL 7021, black grey
<b>Ingress protection</b>	IP 65 to EN 60529
<b>Flammability</b>	UL 94 V-2
<b>Surface resistance</b>	10 <sup>11</sup> Ohm, IEC 60093
<b>Temperature range</b>	-20° C to +60° C



# Limanda

## Product range

Order No.	Type	Dimensions (mm) H x W x D	Weight (g)
<b>27.03 03 00</b>	Limanda I	311 x 281 x 72	1200
<b>27.03 03 01</b>	Limanda I EMC	311 x 281 x 72	1200
<b>27.03 03 17</b>	Limanda I for OP17	311 x 281 x 97	1500
<b>27.03 02 00</b>	Limanda II	270 x 248 x 64	800
<b>27.03 02 01</b>	Limanda II EMC	270 x 248 x 64	800



Limanda enclosure system for installation of different hand held operator panels.



Limanda I for OP17 - Supplied ready for installation of the Siemens OP17 operator panel without additional fitting material.



Limanda II with fitted command unit

## Accessories

### Quiver

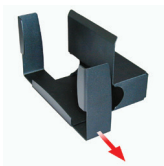

Order No.	Execution
<b>27.03 00 89</b>	for Limanda II
<b>27.03 00 91</b>	for Limanda II with intermediate frame
<b>27.03 00 86</b>	for Limanda I
<b>27.03 00 90</b>	for Limanda I with intermediate frame

### Front plate



Order No.	Execution
<b>27.03 02 90</b>	for Limanda II EMC
<b>27.03 03 90</b>	for Limanda I EMC
<b>27.03 02 80</b>	for Limanda II
<b>27.03 03 80</b>	for Limanda I

### Handle set



Order No.	Execution
<b>27.03 00 83</b>	for Limanda I without push button
<b>27.03 00 71</b>	for Limanda I with 3-step enabling switch, right-hand version
<b>27.03 00 72</b>	for Limanda I with 3-step enabling switch, left-hand version

**Accessories**

**Mounting set**

Order No.	Execution
<b>27.03 02 82</b>	for Siemens TP 170/ TP070

**Inclining adapter for holder**



Order No.	Execution	Weight (g)
<b>50.02 00 05</b>	Mounting directly onto tube GT 48/2	776
<b>50.02 00 06</b>	Mounting directly onto profile GTK electronic	804
<b>50.02 00 07</b>	Mounting directly on wall or machine	490

**Table stand**

Order No.	Execution
<b>27.03 00 87</b>	for Limanda II, set = 2 pcs

**Carrying strap**



Carrying strap in 2 Executions: Standard execution and comfort execution: strengthened execution with shoulder pad

Order No.	Execution
<b>27.03 00 85</b>	for Limanda
<b>27.03 00 92</b>	for Limanda, Comfort

**Intermediate frame**



Order No.	Execution
<b>27.03 02 88</b>	for Limanda II EMC
<b>27.03 00 88</b>	for Limanda I EMC
<b>27.03 02 81</b>	for Limanda II
<b>27.03 03 81</b>	for Limanda I

**Holder**

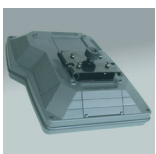

Order No.	Execution
<b>27.03 00 84</b>	Enables rapid removal of the Limanda from the inclining adapter (for Limanda I and II). There is a gap of 19.5 mm between the Limanda and the holder for assembly purposes.

**Cable connection with bending protection**



Order No.	Execution
<b>08.10 01 16</b>	M6
<b>08.10 01 20</b>	M20
<b>08.10 01 25</b>	M25

Further accessories see chapter „Electro-mechanical components“



## Technical details



Limanda I  
Order No. **27.03 03 00**

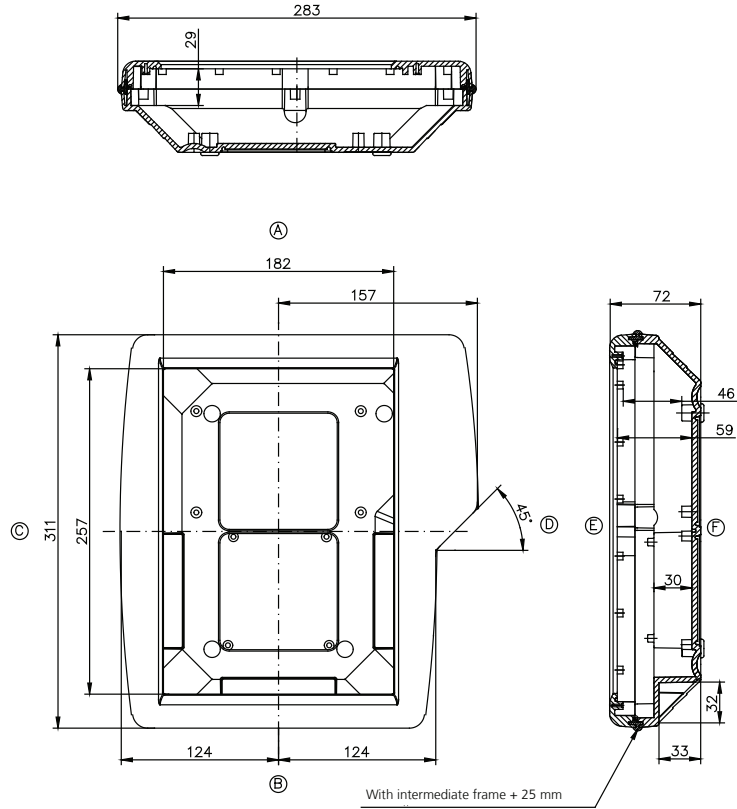

Limanda II  
Order No. **27.03 02 00**

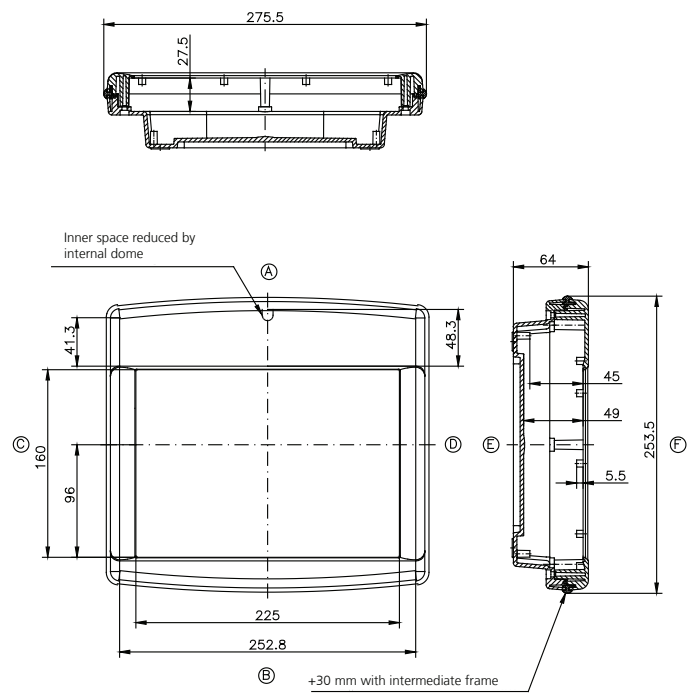



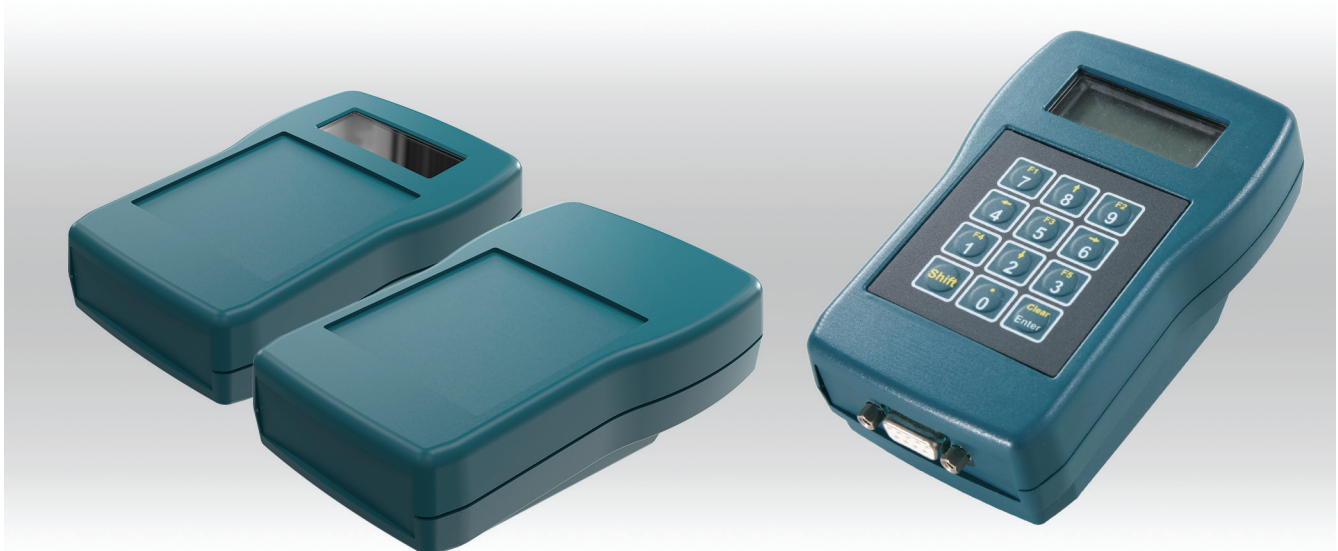

- + ABS hand held enclosure for data acquisition and measurement
- + With integrated battery compartment
- + Execution with or without display opening
- + Optional EMC Execution with internal coating

**Included in delivery**

5-part enclosure with top and base, battery compartment, battery compartment cover, head and shaft cover, fixing and enclosure screws. Open Execution incl. display screen and punched seal.

**Technical data**

<b>Material</b>	ABS
<b>Ingress protection</b>	IP 40 to EN 60529
<b>Surface resistance</b>	$4 \times 10^{14}$ Ohm, IEC 60093
<b>Flammability</b>	UL 94 HB
<b>Colour</b>	top and base, battery compartment cover, head/shaft panel: RAL 5020, ocean blue keyboard cover, battery compartment/battery pack: RAL 7024, graphite grey
<b>Temperature range</b>	-40 °C to +80 °C



# Taguan 130

## Product range

Type	Order No.	Execution	Dimensions H x W x D (mm)	Weight (g)
Taguan 130 FO	<b>27.01 02 00</b>	flat, open	80/70 x 125 x 36,7 / 28,5	130
Taguan 130 FG	<b>27.01 02 01</b>	flat, closed	80/70 x 125 x 36,7 / 28,5	110
Taguan 130 TO	<b>27.01 02 10</b>	deep, open	80/70 x 125 x 46,7 / 28,5	123
Taguan 130 TG	<b>27.01 02 11</b>	deep, closed	80/70 x 125 x 46,7 / 28,5	140

## Components mounting options

Component options	Type T130 FO	Type T130 FG	Type T130 TO	Type T130 TG
Display max. view area 45 x 17,4 mm max. mounting dimensions 65 x 29 mm	•		•	
Chipcard reader in head section	•	•	•	•
Scanner	•	•	•	•
PCMCIA slot	•	•	•	•
D-Sub interface 9-pin	•	•	•	•
D-Sub interface 15-pin	•	•	•	•
9 V monobloc	•	•	•	•
4 R3 micro-cells (AAA)	•	•	•	•
1. PCB (main board)	•	•	•	•
2. PCB (adapter board)			•	•
Membrane keypad	•	•	•	•

## Accessories

### Battery holder



Order No.	Execution
<b>27.01 02 80</b>	for 4 micro-cells (AAA)
<b>27.01 02 81</b>	for 9 V monobloc

### Shaft cover



Order No.	Execution
<b>27.01 02 85</b>	Shaft cover in enclosure colour
<b>27.01 02 86</b>	Shaft cover transparent
<b>27.01 02 87</b>	Shaft cover for infrared

### Clip



Order No.
<b>27.01 02 82</b>

### Spare screw set

Order No.
<b>27.01 00 90</b> Taguan

### Spare display screen set

Order No.
<b>27.01 02 88</b> Taguan 130

### Keypad

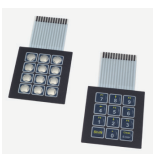

Order No.	Execution
<b>82.10 00 01</b>	FT 130b, 12 keys, printed, common connection
<b>82.10 00 02</b>	FT 130e, 12 keys, with insert, matrix

### Connector

Order No.	Execution
<b>82.20 00 13</b>	13-pole

Further accessories see chapter „Electro-mechanical components“

# Taguan 130

## Technical details

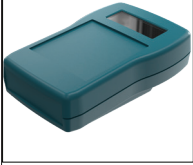
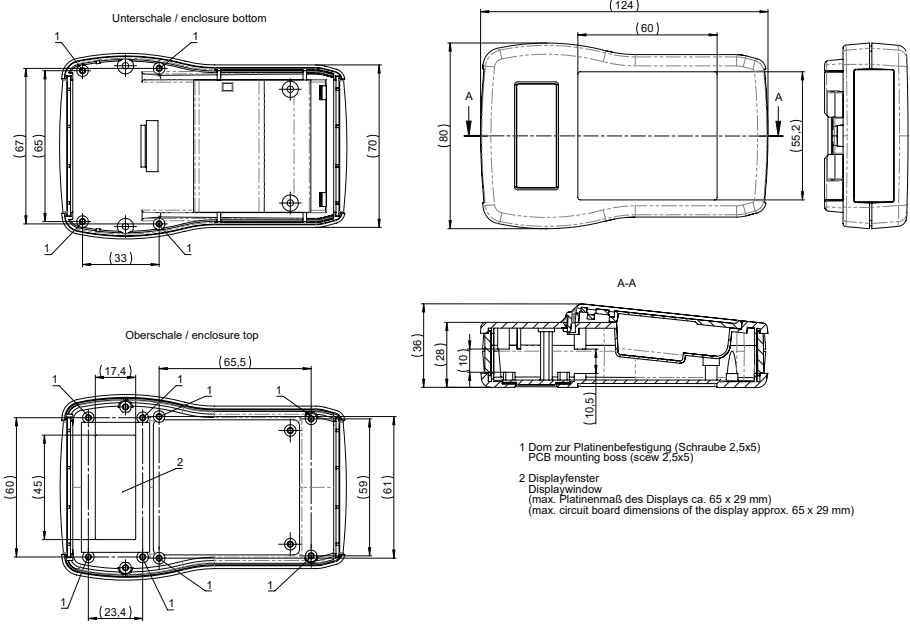
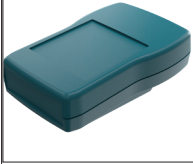
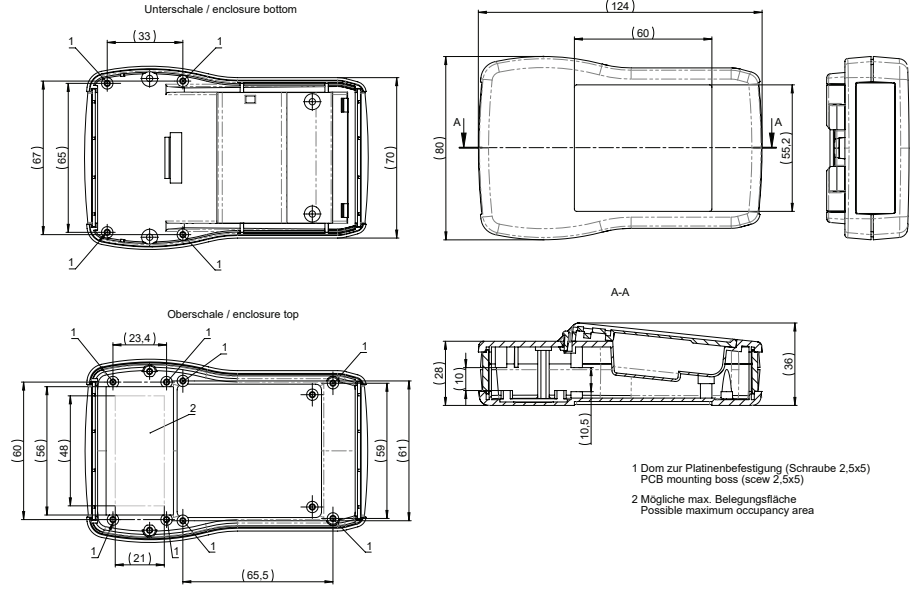
	<table border="1"> <thead> <tr> <th>Type</th> <th>Execution</th> <th>Order No.</th> </tr> </thead> <tbody> <tr> <td>Taguan 130 FO</td> <td>flat, open</td> <td><b>27.01 02 00</b></td> </tr> </tbody> </table> <p>(max. PCB size of displays ca. 65 x 29 mm)</p>	Type	Execution	Order No.	Taguan 130 FO	flat, open	<b>27.01 02 00</b>	 <p>1 Dom zur Platinenbefestigung (Schraube 2,5x5) PCB mounting boss (screw 2,5x5)</p> <p>2 Displayfenster Displaywindow (max. Platinenmaß des Displays ca. 65 x 29 mm) (max. circuit board dimensions of the display approx. 65 x 29 mm)</p>
Type	Execution	Order No.						
Taguan 130 FO	flat, open	<b>27.01 02 00</b>						
	<table border="1"> <thead> <tr> <th>Type</th> <th>Execution</th> <th>Order No.</th> </tr> </thead> <tbody> <tr> <td>Taguan 130 FG</td> <td>flat, closed</td> <td><b>27.01 02 01</b></td> </tr> </tbody> </table>	Type	Execution	Order No.	Taguan 130 FG	flat, closed	<b>27.01 02 01</b>	 <p>1 Dom zur Platinenbefestigung (Schraube 2,5x5) PCB mounting boss (screw 2,5x5)</p> <p>2 Mögliche max. Belegungsfläche Possible maximum occupancy area</p>
Type	Execution	Order No.						
Taguan 130 FG	flat, closed	<b>27.01 02 01</b>						

Accessories

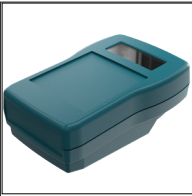

Type	Execution	Order No.
Taguan 130 TO	deep, open	<b>27.01 02 10</b>

(max. PCB size of displays ca. 65 x 29 mm)

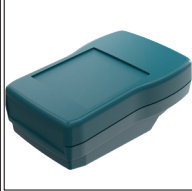
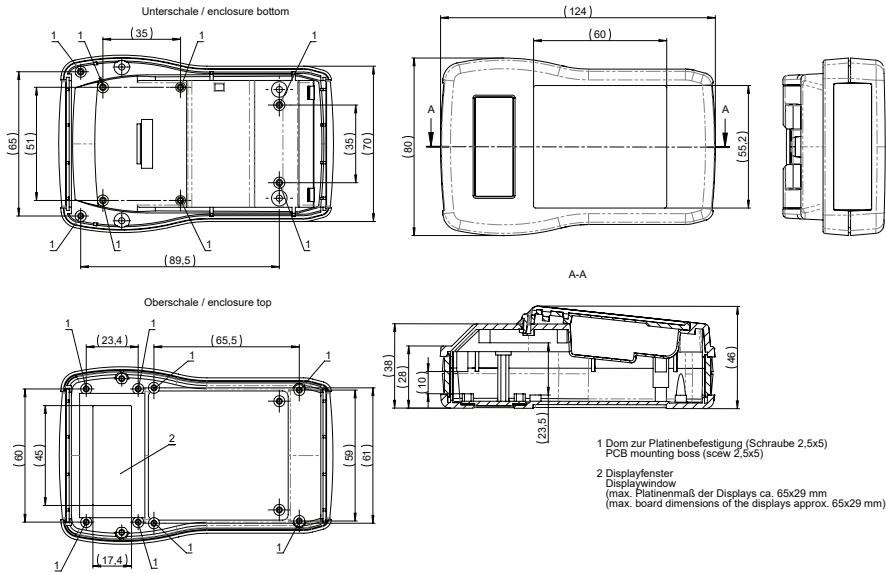

Type	Execution	Order No.
Taguan 130 TG	deep, closed	<b>27.01 02 11</b>

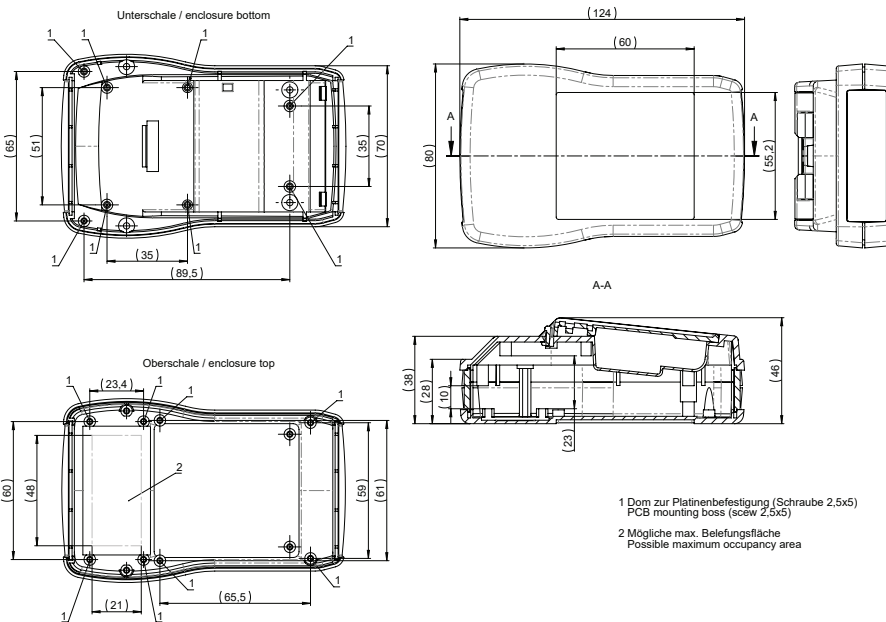

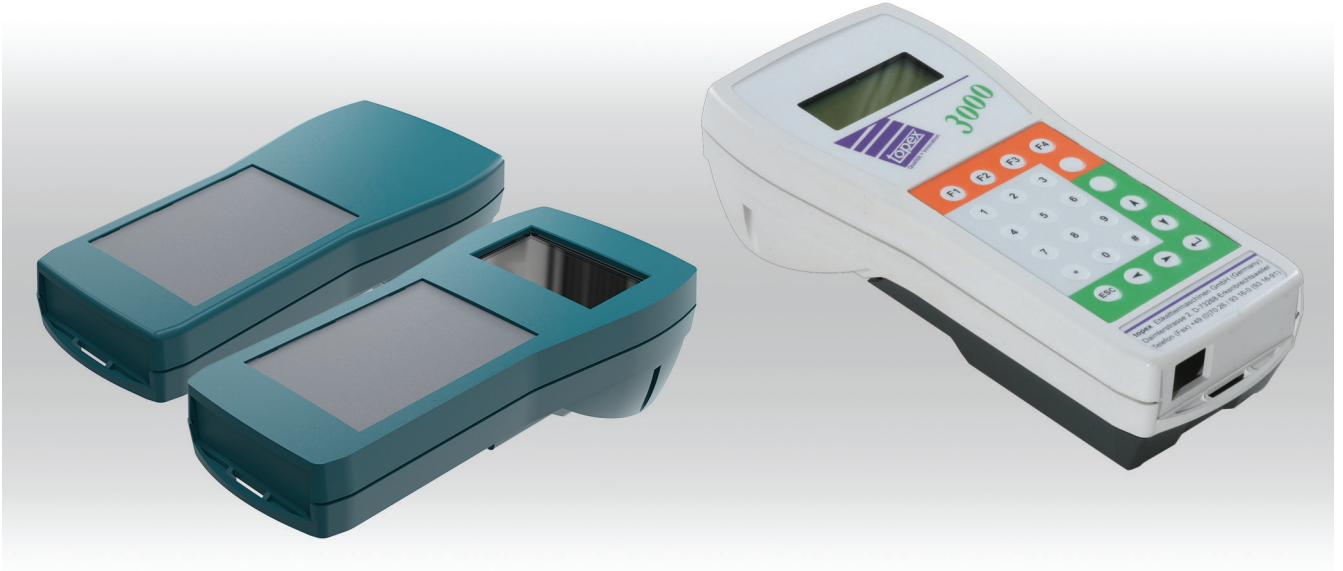

- + ABS hand held enclosure for data acquisition and measurement
- + With integrated battery compartment
- + Execution with or without display openings
- + Optional EMC Execution with internal coating

### Included in delivery

Enclosure with top and base, keypad cover, head and shaft cover, fastening and enclosure screws. Open Execution incl. display screen and punched seal.  
Please order battery compartment separately.

### Technical data

<b>Material</b>	ABS
<b>Ingress protection</b>	IP 40 to EN 60529
<b>Surface resistance</b>	$4 \times 10^{14}$ Ohm, IEC 60093
<b>Flammability</b>	UL 94 HB
<b>Colour</b>	top and base, battery compartment cover, head/shaft cover: RAL 5020, ocean blue keyboard cover, battery compartment/battery pack: RAL 7024, graphite grey
<b>Temperature range</b>	-40 °C to +80 °C

**Product range**

Type	Order No.	Execution	Dimensions H x W x D (mm)	Weight (g)
Taguan 180 O	<b>27.01 04 00</b>	open	84/70 x 180 x 53,5/38,5	140
Taguan 180 G	<b>27.01 04 01</b>	closed	84/70 x 180 x 53,5/38,5	170
Taguan 230 O	<b>27.01 06 00</b>	open	97/70 x 229 x 53,5/38,5	230
Taguan 230 G	<b>27.01 06 01</b>	closed	97/70 x 229 x 53,5/38,5	400

Components mounting options

Component options	Type T180 O	Type T180 G	Type T230 O	Type T230 G
Display (max. view area 56 x 33 mm; max. mounting dimensions 66 x 46 mm)	•			
Display (max. view area 66 x 43 mm; max. mounting dimensions 78 x 56 mm)			•	
Chipcard reader in head section	•	•	•	•
Chipcard reader in shaft section	•	•	•	•
Magnetic card reader	•	•	•	•
Scanner	•	•	•	•
PCMCIA slot	•	•	•	•
D-Sub interface 9-pin	•	•	•	•
D-Sub interface 15-pin	•	•	•	•
D-Sub interface 25-pin	•	•	•	•
Battery pack	•	•	•	•
4 micro-cells R6 (AA)	•	•	•	•
9 V monobloc	•	•	•	•
1st board (main board)	•	•	•	•
2nd board (adapter board)	•	•	•	•
Membrane keypad	•	•	•	•
Switching mat, 12 keys, in combination with keypad plate	•	•	•	•
Switching mat, 24 keys	•	•		
Switching mat, 36 keys			•	•



## Accessories

### Battery holder



Order No.

**27.01 00 94**

### Battery compartment empty



Order No.

**27.01 00 80**

Execution

for 4 micro-cells (AA)

### Battery charging station



Order No.

**27.20 00 01**

### Rechargeable battery pack



Order No.

**27.20 00 03**

Execution

NiMH 4.8 V / 2100 mAh

### Blende



Order No.

**27.01 02 85**

Execution

Shaft cover, in enclosure colour

**27.01 02 86**

Shaft cover, transparent

**27.01 02 87**

Shaft cover for infrared

**27.01 00 85**

Head cover, stepped in enclosure colour

**27.01 00 87**

Head cover, stepped for infrared

**27.01 00 89**

Head cover, stepped transparent

**27.01 00 91**

Head cover, straight in enclosure colour

**27.01 00 92**

Head cover, straight transparent

**27.01 00 93**

Head cover, straight for infrared

### Display fixing set



Order No.

**27.01 04 80**

Execution

Taguan 180

**27.01 06 80**

Taguan 230

**27.01 06 88**

Taguan 230



**Accessories**

**Spare display screen**

Order No.	Execution
<b>27.01 04 88</b>	for Taguan 180
<b>27.01 06 88</b>	for Taguan 230

**Spare screws set**

Order No.
<b>27.01 00 90</b>

**Spring contact**



Contacts for the battery pack (Company Bourns, type 70ADJ002ML1), for mounting in enclosure bottom part

Order No.	Execution
<b>27.01 00 82</b>	2-pole

**Wrist strap**



Protection against falling down, or as carrying aid

Order No.
<b>27.01 00 83</b>

**Hand strap**



with Velcro fastener for adjustment, consisting of holding strap, adapter and screws

Order No.	Execution
<b>27.01 04 84</b>	for Taguan 180
<b>27.01 06 84</b>	for Taguan 230

**Switch mat set**



consisting of keypad plate, silicone switching mat and keypad circuit board with connecting cable

Order No.	Execution
<b>27.01 00 95</b>	12 keys, for Taguan 180 / 230
<b>27.01 04 81</b>	24 keys for Taguan 180
<b>27.01 06 81</b>	36 keys, for Taguan 230

**Connector charger**



Order No.	Execution
<b>27.20 00 02</b>	with primary adapter

Further accessories see chapter „Electro-mechanical components“



# Taguan 180/230

## Technical details

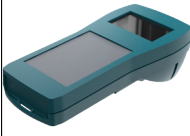
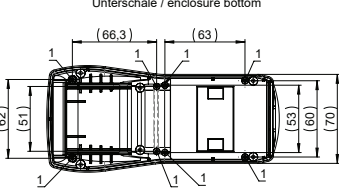
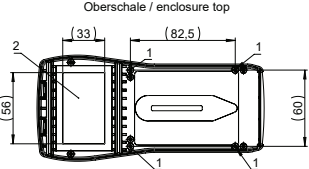
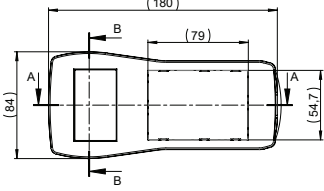
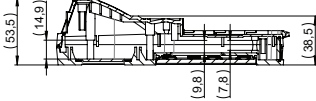
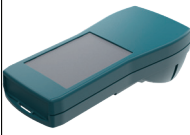
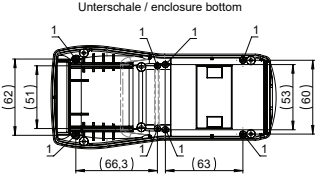
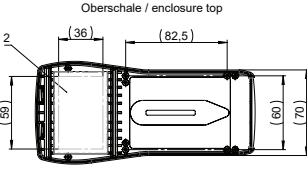
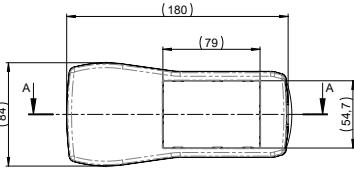
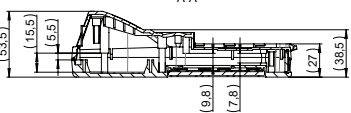
	<p>Type                      Execution                      Order No.</p> <p>Taguan 180 O            open                              <b>27.01 04 00</b></p> <p>(max. PCB size of displays ca. 66 x 46 mm)</p>	
	<p>Unterschale / enclosure bottom</p>  <p>Oberschale / enclosure top</p> 	  <p>1 Dom zur Platinenbefestigung (Schraube 2,5x5) PCB mounting boss (screw 2,5x5)</p> <p>2 Displayfenster Displaywindow (max. Platinenmaß des Display ca. 66x46 mm) (max. circuit board dimensions of the display approx. 66x46 mm)</p>
	<p>Type                      Execution                      Order No.</p> <p>Taguan 180 G            closed                            <b>27.01 04 01</b></p>	
	<p>Unterschale / enclosure bottom</p>  <p>Oberschale / enclosure top</p> 	  <p>1 Dom zur Platinenbefestigung ( Schraube 2,5x5) PCB mounting boss (screw 2,5x5)</p> <p>2 Mögliche max. Belegungsfläche Possible maximum occupancy area</p>

Accessories

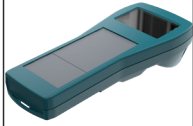

Type	Execution	Order No.
Taguan 230 O	open	<b>27.01 06 00</b>

(max. PCB size of displays ca. 78 x 56 mm)

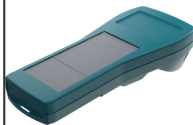
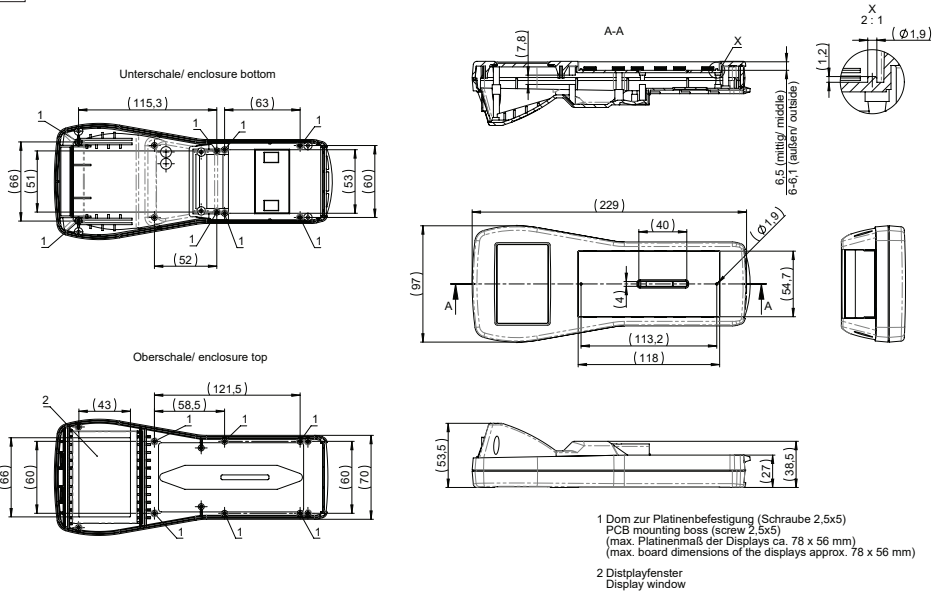

Type	Execution	Order No.
Taguan 230 G	closed	<b>27.01 06 01</b>

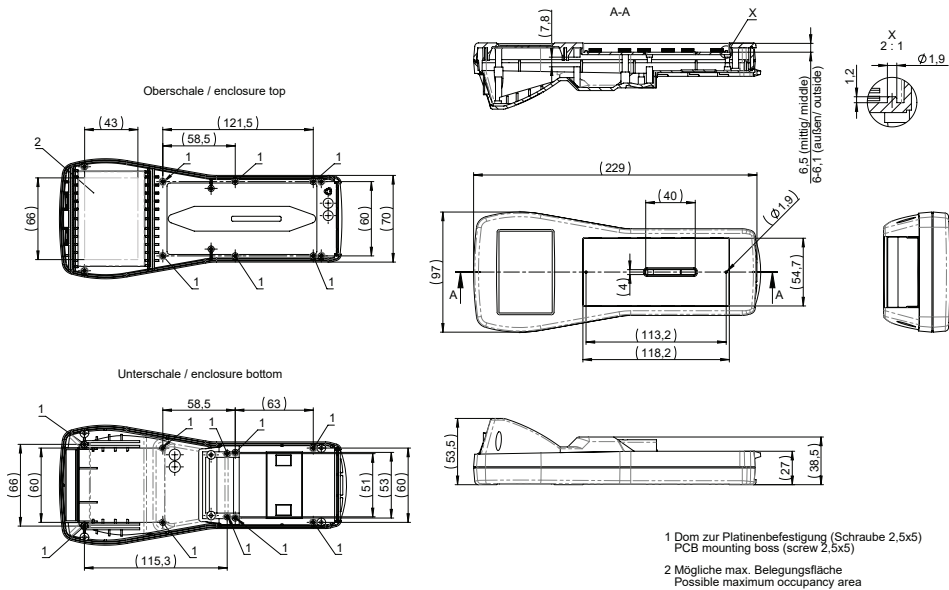

## Beluga 180/220

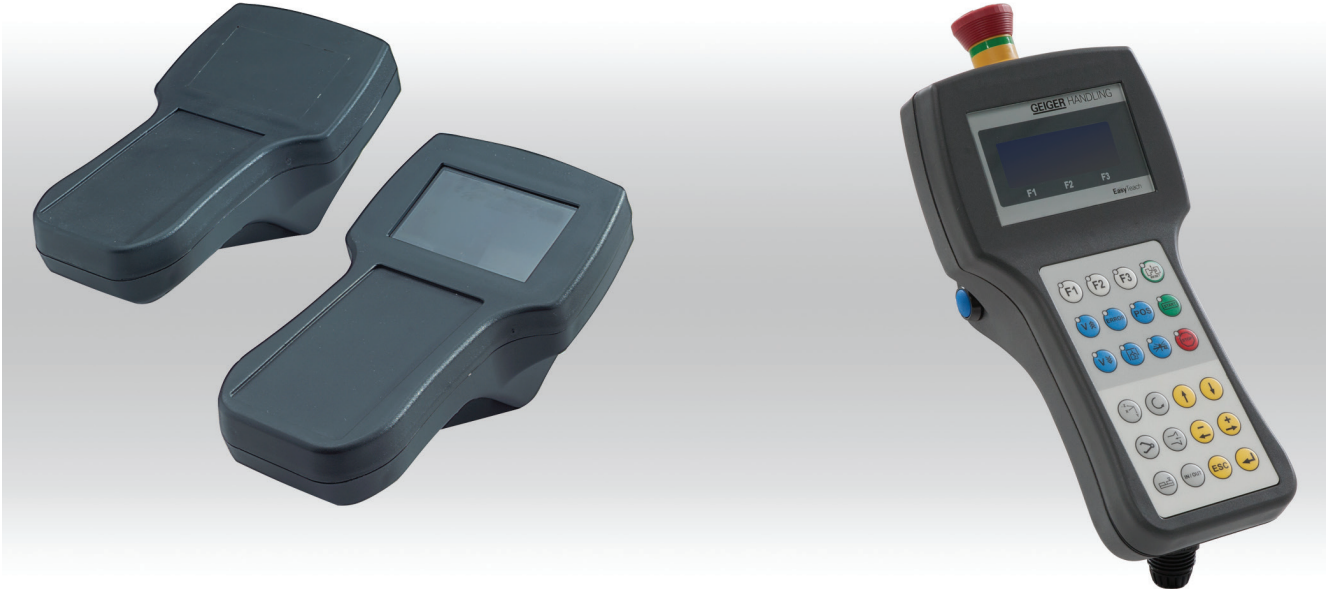

- + Polyamide hand held enclosure for MCR- and automation engineering
- + Execution with or without display opening
- + Prepared for acceptance of keypads/silicone switch mats
- + Optional EMC Execution with internal coating and EMC seal

### Included in delivery

Double-leaf enclosure with top and base unit, each with fixing domes, fastening screws and enclosure screws.  
Open Execution incl. display screen and punched seal.

### Technical data

Material	Polyamide
Ingress protection	IP 65 to EN 60529
Surface resistance	$4 \times 10^{14}$ Ohm, IEC 60093
Flammability	UL 94 V-2
Colour	RAL 7021, black grey
Temperature range	-40 °C to +60 °C

**Product range**

Type	Order No.	Execution	Dimensions H x W x D (mm)	Weight (g)
Beluga 180 O	<b>27.02 02 00</b>	open	106/75 x 187 x 50	290
Beluga 180 G	<b>27.02 02 01</b>	closed	106/75 x 187 x 50	228
Beluga 220 O	<b>27.02 04 00</b>	open	116/85 x 220 x 51	262
Beluga 220 G	<b>27.02 04 01</b>	closed	116/85 x 220 x 51	254

Components mounting options

Component options	Type B180 O	Type B180 G	Type B220 O	Type B220 G
Display max. view area 42 x 65 mm max. mounting dimensions 56,4 x 74 mm or 54 x 80 mm	•			
Display max. view area 49 x 78 mm max. mounting dimensions 71,5 x 84 mm or 70,5 x 86 mm			•	
Emergency stop button	•	•	•	•
Push button	•	•	•	•
Hand wheel		•		•
Step switch		•		•
Joy stick	•		•	
Cable outlet up to M 16	•	•	•	•
Cable outlet up to M 20			•	•
1st board (main board)	•	•	•	•
Other boards	•	•	•	•

**Accessories**

**Battery compartment empty**



Order No.

**27.02 00 85**

**Battery holder**

Order No. Execution

**27.02 00 86** for 4 round cells for battery compartment

**27.02 00 87** for 9 V monobloc for battery compartment

**Display fixing set**



Order No. Execution

**27.01 06 80** Beluga 180

**27.02 04 82** Beluga 220



## Accessories

### Spare display screen

Order No.	Execution
<b>27.01 06 88</b>	Beluga 180
<b>27.02 04 83</b>	Beluga 220

### Spare screw set

Order No.	Execution
<b>27.02 00 82</b>	Beluga 180/220

### Keypads



Order No.	Execution
<b>82.10 00 03</b>	Keypad FT 180b, 15 keys, printed (Matrix)
<b>82.10 00 04</b>	Keypad FT 180e, 15 keys, with insert (Matrix)
<b>82.10 00 07</b>	Keypad FT 180ge, 12 keys, with insert (common connection)
<b>82.10 00 05</b>	Keypad FT 220b, 18 keys, printed
<b>82.10 00 06</b>	Keypad FT 220e, 18 keys, with insert (Matrix)

### Hook set



Order No.	Execution
<b>27.02 00 80</b>	without magnet
<b>27.02 00 81</b>	with magnet

### Hand strap

Order No.	Execution
<b>27.02 00 83</b>	for Beluga 180/220

### Cable connection with bending protection



Order No.	Execution
<b>08.10 01 16</b>	M16x1.5
<b>08.10 01 20</b>	M20x1.5

### Wall holder set

Order No.	Execution
<b>27.02 00 84</b>	for hook set

Further accessories see chapter „Electro-mechanical components“

Technical details



Type	Execution	Order No.
Beluga 180 O	open	<b>27.02 02 00</b>
Beluga 180 G	closed	<b>27.02 02 01</b>

(max. PCB size of displays ca. 74 x 56,4 mm or 80 x 54 mm)

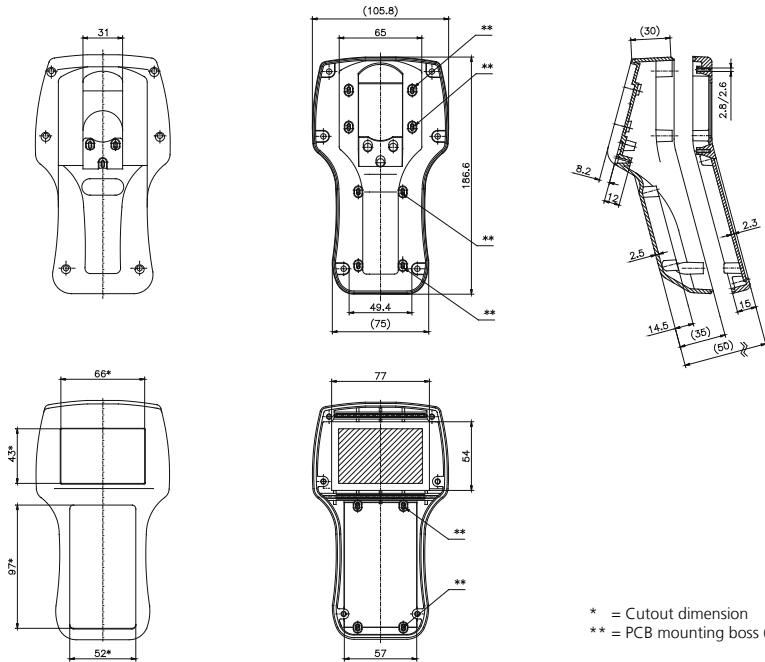

\* = Cutout dimension  
 \*\* = PCB mounting boss (screw 3 x 8)



Type	Execution	Order No.
Beluga 220 O	open	<b>27.02 04 00</b>
Beluga 220 G	closed	<b>27.02 04 01</b>

(max. PCB size of displays ca. 84 x 71,5 mm or 86 x 70,5 mm)

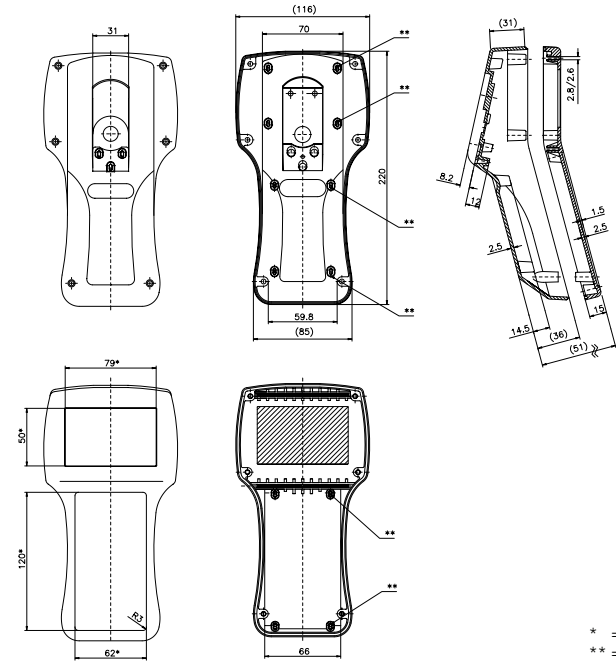

\* = Cutout dimension  
 \*\* = PCB mounting boss (screw 3 x 8)



## Beluga 380



- + Polyamide hand held enclosure for MCR- and automation engineering
- + Execution with or without display opening
- + Prepared for keypads/silicone switch mats
- + Optional EMC Execution with internal coating and EMC seal

### Included in delivery

Double-leaf enclosure with top and base unit, each with fixing domes, mounting / hook set, fastening and enclosure screws.

### Technical data

Material	Polyamide
Ingress protection	IP 65 to EN 60529
Surface resistance	$10^{12}$ Ohm, IEC 60093
Flammability	UL 94 V-2
Colour	RAL 7021, black grey
Temperature range	-40 °C to +60 °C



**Product range**

Type	Order No.	Execution	Dimensions H x W x D (mm)	Weight (g)
Beluga 380	<b>27.02 05 01</b>	closed	380 x 117 x 68	670

Components mounting options

Component options	Type B380
Display (max. view area / max. mounting dimensions see drawing on page 53 - 58)	•
Emergency stop button	•
Push button	•
Enabling switch	•
Hand wheel	•
Step switch	•
Joy stick	•
Cable outlet up to M 20	•
1st board (main board)	•
Other boards	•



Fitting possibility of large displays  
(1/4 VGA)



Integrated hook set



Large installation space for  
electronic devices



Hook set, can be used as release  
lever

**Accessories**

**Spare screws set**

Order No.	Execution
<b>27.02 05 83</b>	Beluga 380

**Hand strap**

Order No.	Execution
<b>27.02 05 81</b>	for Beluga 380

**Cable gland with bending protection**



Order No.	Execution
<b>08.10 01 16</b>	M16x1.5
<b>08.10 01 20</b>	M20x1.5



# Beluga 380

## Accessories

### Carrying strap

Order No.	Execution
<b>27.02 05 80</b>	for Beluga 380

### Wall holder set



Order No.
<b>27.02 05 82</b>

Further accessories see chapter „Electro-mechanical components“

## Technical details

Type	Execution	Order No.
Beluga 380	closed	<b>27.02 05 01</b>

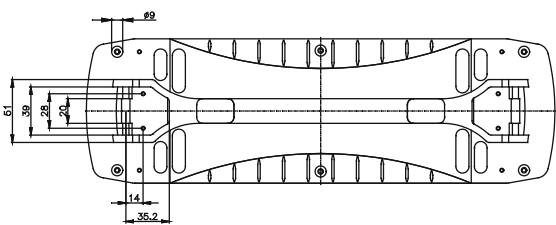
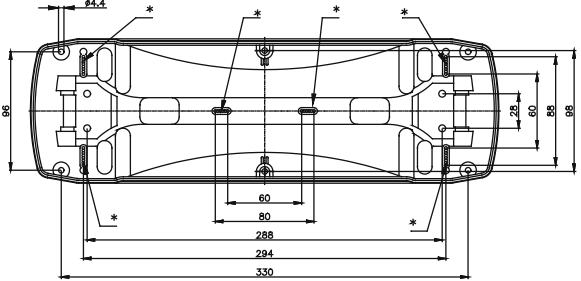
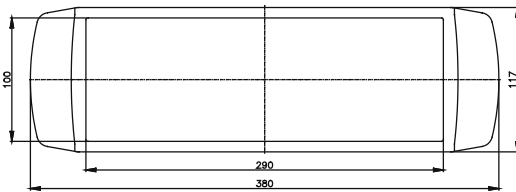
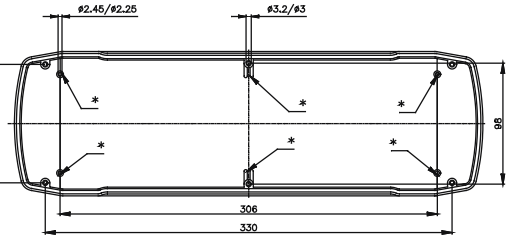
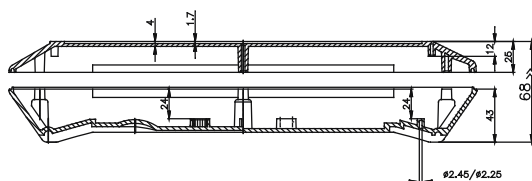
\* = PCB mounting boss (screw 3 x 8)



- + Polyamide hand held enclosure for MCR- and automation engineering
- + Large installation space
- + Execution with closed lid or front frame lid
- + Rear battery compartment
- + Optional EMC Execution with internal coating and EMC seal

**Included in delivery**

Double-leaf enclosure with top and base unit, each with fixing domes, battery compartment lid, fastening and enclosure screws

**Technical data**

<b>Material</b>	Polyamide
<b>Ingress protection</b>	IP 65 to EN 60529
<b>Impact resistance</b>	7 Joule to EN 60529
<b>Flammability</b>	UL 94 HB
<b>Colour</b>	Base and lid: RAL 7021, black grey Rear cover: RAL 5003, sapphire blue
<b>Temperature range</b>	-40 °C to +60 °C



# Pilot 250

## Product range

Type	Order No.	Execution upper shell	Dimensions H x W x D (mm)	Weight (g)
Pilot 250/1	<b>29.25 00 01</b>	closed	140/120 x 280 x 86	700
Pilot 250/2	<b>29.25 00 02</b>	lid frame	140/120 x 280 x 86	460

## Accessories

### Battery holder



Order No.	Execution
<b>29.25 01 03</b>	for 4 micro-cells
<b>29.25 01 04</b>	for 9V monobloc

### Front plate

Order No.	Execution
<b>29.25 01 01</b>	for Pilot 250/2

### Cable gland with bending protection



Order No.	Execution
<b>08.10 01 16</b>	M16x1.5
<b>08.10 01 20</b>	M20x1.5

### Magnet holder



Order No.
<b>29.25 01 02</b>

### Wall holder



Order No.
<b>29.25 01 05</b>

Further accessories see chapter „Electro-mechanical components“

Technical details



Type	Execution	Order No.
Pilot 250/1	closed	29.25 00 01
Pilot 250/2	lid frame	29.25 00 02

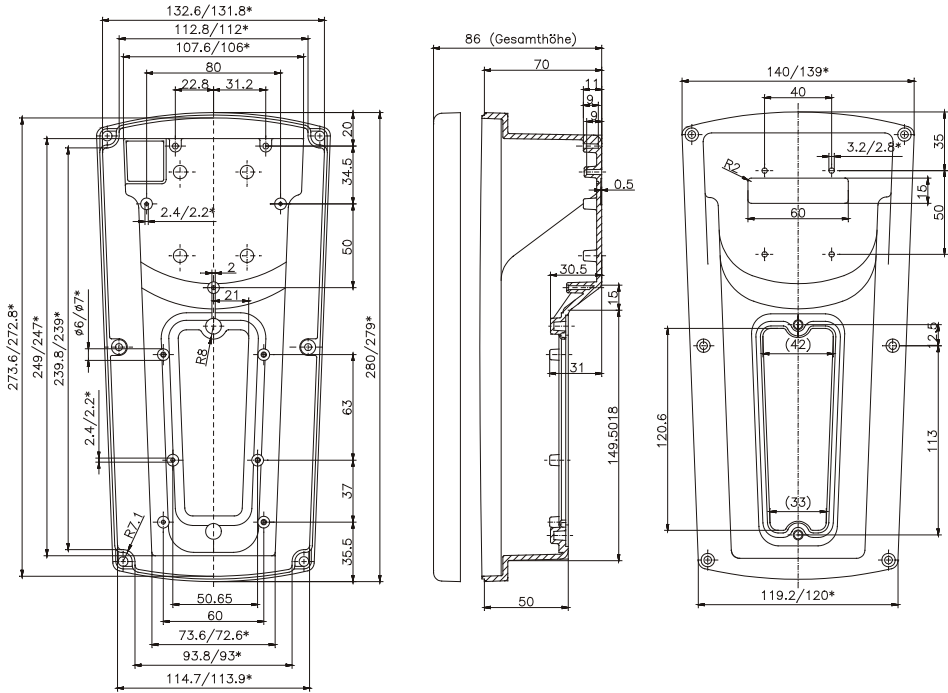

\* = Conical form tapering downwards

Closed lid

Lid frame

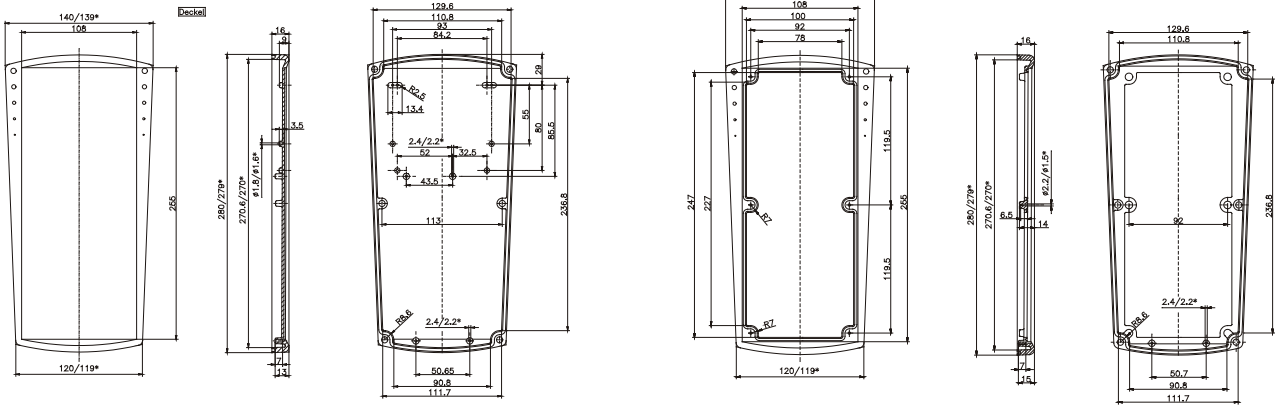

## Pilot 50



+ Polyamide / PVC hand held enclosure for MCR and automation engineering

+ Large installation space

+ Variable length by using profile technology

+ Robust construction

### Included in delivery

Enclosure system consisting of internal polyamide enclosure with end covers, two lateral PVC cover profiles, Alucobond composite front plate, rear wall, 2 external end covers, with M 25 x 1.5 threaded hole for cable gland

### Technical data

<b>Material</b>	Polyamide 6 PVC
<b>Ingress protection</b>	IP 65 to EN 60529
<b>Impact resistance</b>	5 Joule, EN 60079-0
<b>Flammability</b>	End covers: UL 94 HB
<b>Colour</b>	End covers: RAL 1003, rape yellow PVC-profile: RAL 9005, jet black

## Product range

External enclosure dimensions H x W x D (mm)	Order No. Standard complete	Weight (g)	Standard rear wall separate	Standard front plate separate
280 x 191 x 76	<b>29.11 10 00</b>	<b>1340</b>	<b>29.11 00 01</b>	<b>29.11 00 02</b>
330 x 191 x 76	<b>29.12 10 00</b>	<b>1520</b>	<b>29.12 00 01</b>	<b>29.12 00 02</b>
440 x 191 x 76	<b>29.13 10 00</b>	<b>1940</b>	<b>29.13 00 01</b>	<b>29.13 00 02</b>
Special length	<b>29.19 10 00</b>		<b>29.19 00 01</b>	<b>29.19 00 02</b>

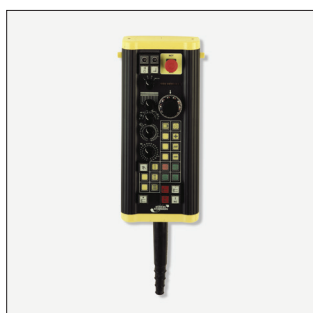

Pilot with small control device



Inner T-slots offer mounting facilities on all sides



Variable fittings

## Accessories

### Mounting set



Order No.	Execution
<b>29.00 00 50</b>	M4, set = 4 pcs

### Front plate

Order No.	Execution
<b>29.11 00 02</b>	for 29.11
<b>29.12 00 02</b>	for 29.12
<b>29.13 00 02</b>	for 29.13
<b>29.19 00 02</b>	Special length

### Cable gland with bending protection



Order No.	Execution
<b>08.10 01 25</b>	M25x1.5

### PCB fixing set



Order No.	Execution
<b>29.00 00 60</b>	Set of 4 pcs incl. spring nuts

### Rear wall

Order No.	Execution
<b>29.11 00 01</b>	for 29.11
<b>29.12 00 01</b>	for 29.12
<b>29.13 00 01</b>	for 29.13
<b>29.19 00 01</b>	Special length

### Cable gland reduction

Order No.	Execution
<b>08.01 25 12</b>	M25 / M12
<b>08.01 25 16</b>	M25 / M16
<b>08.01 25 20</b>	M25 / M20

### Wall holder



Order No.	Execution
<b>29.00 00 70</b>	for Pilot 50 (single)
<b>29.00 00 80</b>	Magnetic wall holder
<b>29.00 10 00</b>	incl. enclosure machining

Further accessories see chapter „Electro-mechanical components“







- + Hand held enclosure for MCR and automation engineering
- + Robust design (Polyamide or Polyester)
- + Execution with handle and integrating cable outlet  
(Pilot 10, 20 standard)

### Included in delivery

Pilot 10/20: enclosure with handle, including cable gland M 20 x 1,5, front plate with fastening screw and wall holder

Pilot 30: two-part Polyester enclosure with self-adhesive aluminium front plate, enclosure screws and wall holder

## Technical data

<b>Material</b>	Pilot 10 and Pilot 20: Polyamide; Pilot 30: Polyester
<b>Ingress protection</b>	IP 65 to EN 60529
<b>Impact resistance</b>	7 Joule, EN 60079-0
<b>Flammability</b>	Pilot 10 and Pilot 20: UL 94 HB Pilot 30: self-extinguishing UL 94 V-0
<b>Colour</b>	RAL 1003, signal yellow Pilot 30: RAL 1021, rape yellow
<b>Temperature range</b>	-40 °C to +60 °C

## Product range

Type	Order No.	Enclosure dimensions incl. handle H x W x D (mm)	Front plate dimensions W x H (mm)	Mounting depth (mm)
Pilot 10	<b>29.40 02 00</b>	70 x 93 x 190	61 x 59	67
Pilot 20	<b>29.30 01 00</b>	115 x 93 x 200	106 x 69	67
Pilot 30	<b>29.50 01 00</b>	164 x 116 x 295	70 x 280	71



One button and two button enclosure Pilot 10 / Pilot 20



Integrated handles on Pilot 10 and Pilot 20

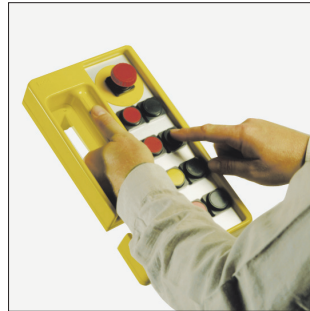

Switch enclosure Pilot 30

## Accessories

### Cable gland with bending protection



Order No.	Execution
<b>08.10 01 20</b>	for Pilot 30

### Mounting plate

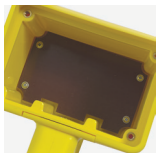

Order No.	Execution
<b>29.31 00 00</b>	for Pilot 20

### Wall holder



Order No.	Execution
<b>29.60 01 00</b>	for Pilot 10/20/30

Further accessories see chapter „Electro-mechanical components“



# Pilot 10/20/30

## Technical details



Type	Order No.	Weight (g)
Pilot 10	<b>29.40 02 00</b>	380
Pilot 20	<b>29.30 01 00</b>	440

**Pilot 10**

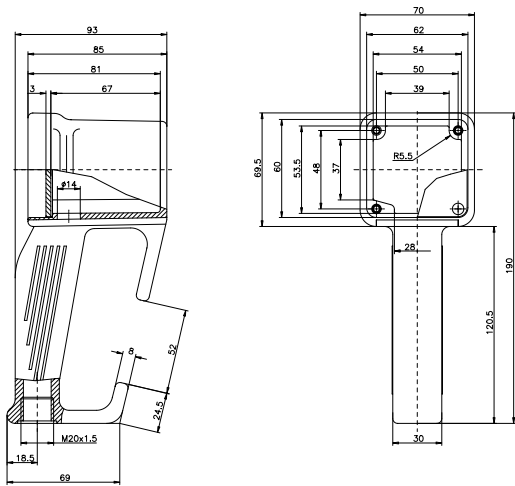

**Pilot 20**

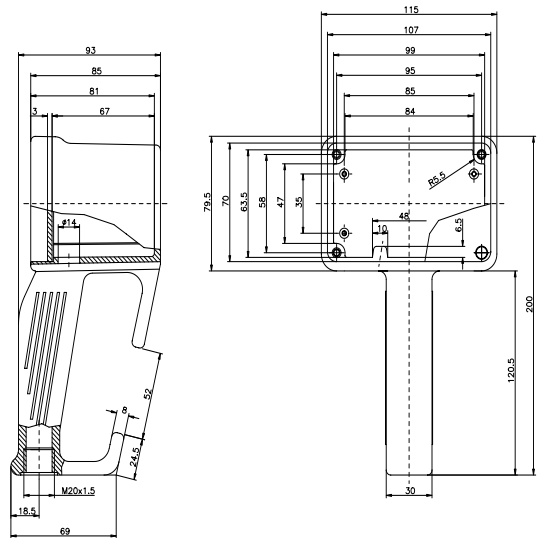

Type	Order No.	Weight (g)
Pilot 30	<b>29.50 01 00</b>	1700

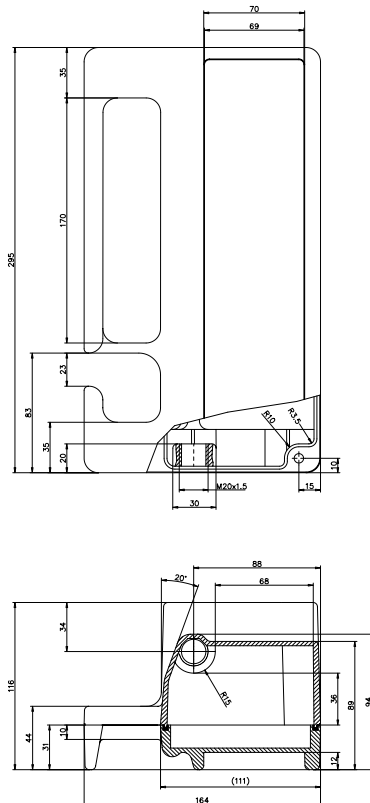



- + Polyamide hand enclosure for automation and control engineering
- + Execution with handle and integrated cable entry
- + Large installation space

#### Included in delivery

Enclosure with handle, including cable gland M 20 x 1.5, front plate, enclosure and front panel screws, and wall holder

### Technical data

<b>Material</b>	Polyamide; front plate: Polystyrene
<b>Ingress protection</b>	IP 65 to EN 60529
<b>Impact resistance</b>	7 Joule, EN 60079-0
<b>Flammability</b>	UL 94 HB
<b>Colour</b>	RAL 1003, signal yellow Pilot 30: RAL 1021, rape yellow
<b>Temperature range</b>	-40 °C to +60 °C



# Pilot 110 - 150

## Product range

Type	Order No.	Enclosure dimensions incl. handle H x W x D (mm)	Front plate dimensions H x W (mm)	Mounting depth (mm)
Pilot 110	<b>29.21 10 00</b>	85 x 85 x 191	77 x 77	63,5
Pilot 120	<b>29.21 20 00</b>	115 x 85 x 191	107 x 77	63,5
Pilot 130	<b>29.21 30 00</b>	85 x 85 x 221	77 x 107	63,5
Pilot 140	<b>29.21 40 00</b>	160 x 85 x 211	152 x 97	63,5
Pilot 150	<b>29.21 50 00</b>	105 x 85 x 266	97 x 152	63,5

## Accessories

### Wall holder

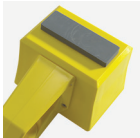

Order No.	Execution
<b>29.00 00 80</b>	Magnetic wall holder for Pilot 120 - 150

Further accessories see chapter „Electro-mechanical components“

Technical details



Type	Order No.	Weight (g)
Pilot 110	<b>29.21 10 00</b>	500

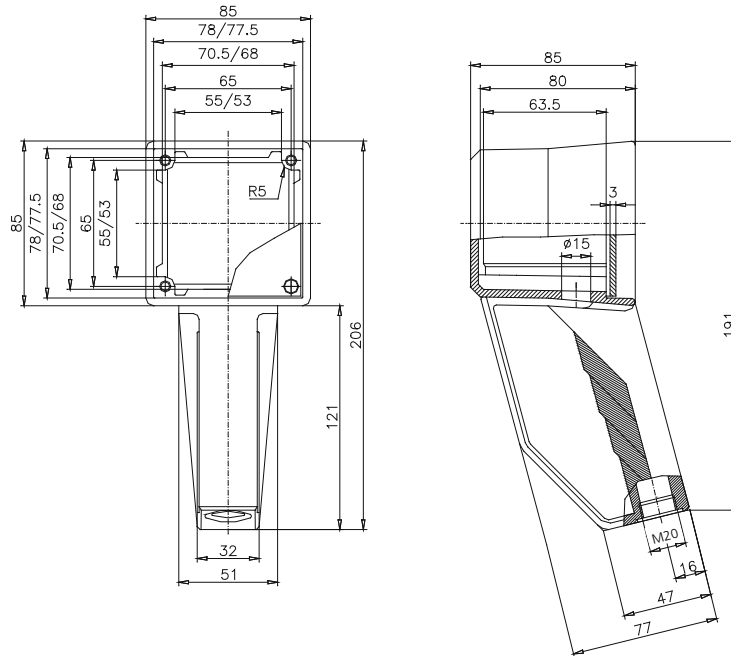

Type	Order No.	Weight (g)
Pilot 120	<b>29.21 20 00</b>	341
Pilot 130	<b>29.21 30 00</b>	341

Pilot 120

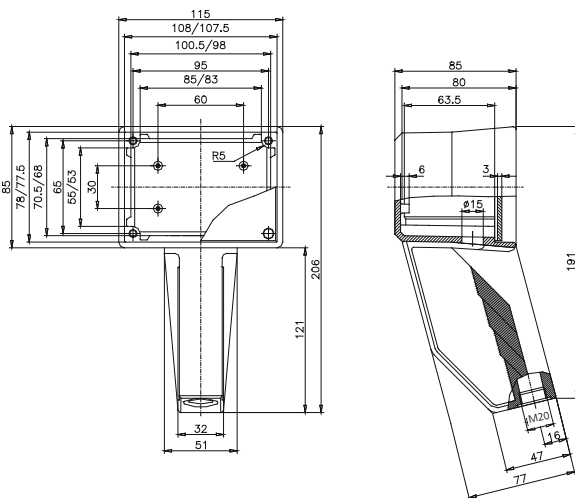

Pilot 130

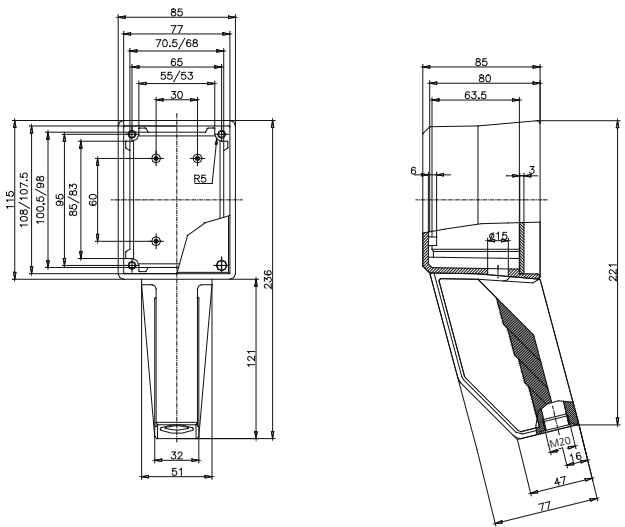

# Pilot 110 - 150

## Technical details



Type	Order No.	Weight (g)
Pilot 140	<b>29.21 40 00</b>	780
Pilot 150	<b>29.21 50 00</b>	780

**Pilot 140**

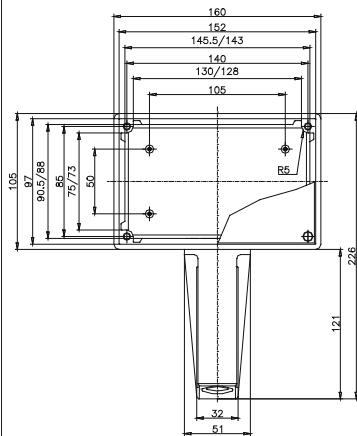

**Pilot 150**

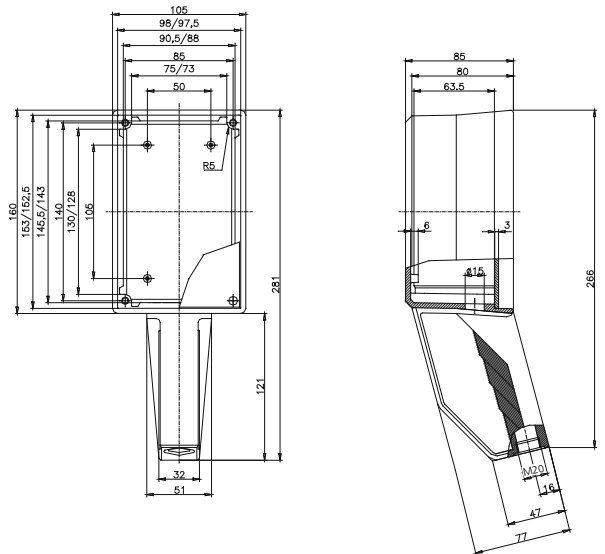



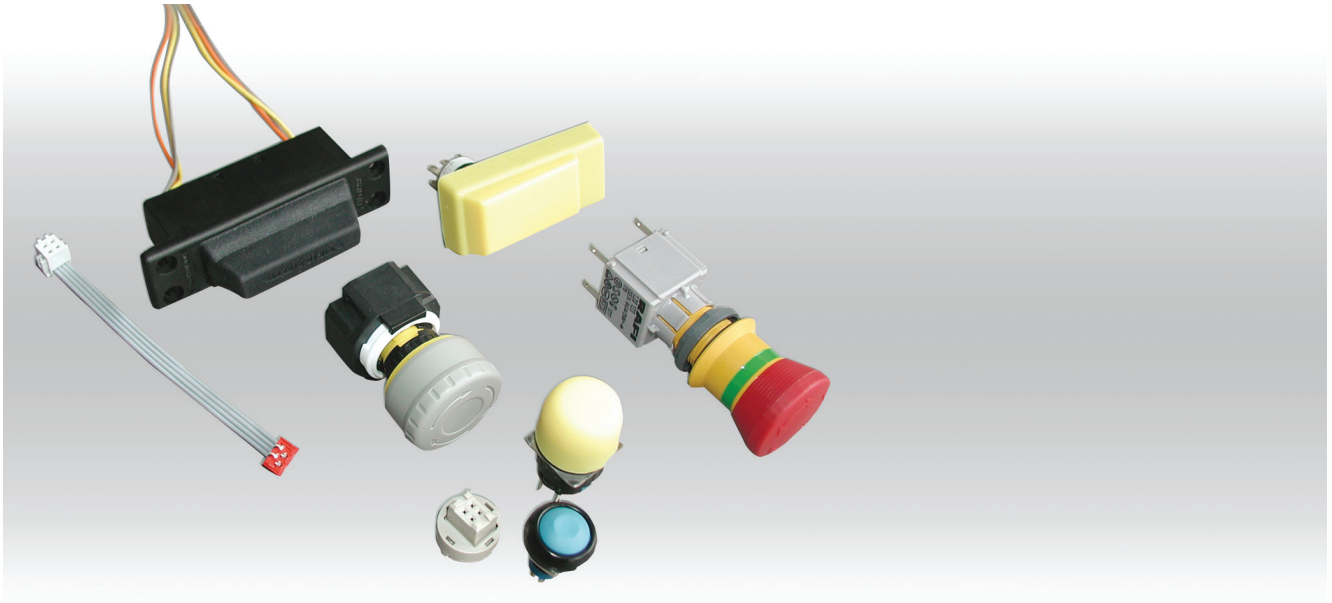

For assembling of enclosures there is available a huge range of switches / push buttons:

- enabling switches
- emergency stop button
- accessories

# Electro-mechanical components

## Components

### Enabling switch



Order No.	Execution
<b>83.50 00 10</b>	2-step enabling switch (1 NO), blue
<b>83.50 00 09</b>	2-step enabling switch (1 NC/ 1 NO), blue

#### Technical data

Contact loading	48 V (AC), 500 mA 250 V (AC), 200 mA 50 V (DC), 200 mA
Ingress protection	IP 67 front side
Temperature range	-40°C to +125°C (no condensation)
Volume resistance	max. 50 mW (initial value)
Service life	≥ 5 x 10 <sup>5</sup> switchings

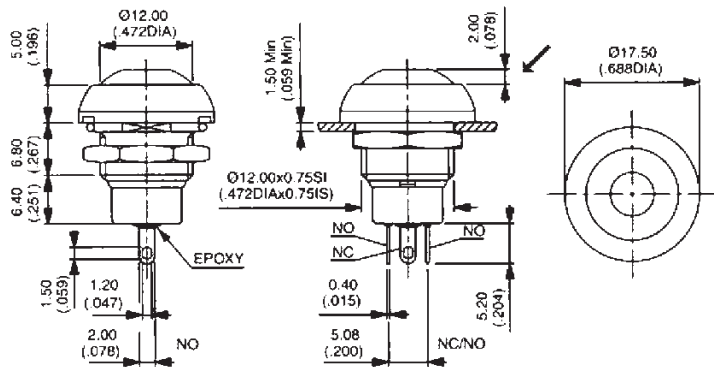

### Emergency stop button



Order No.	Execution
<b>83.50 00 02</b>	Emergency stop button (2NC), Ø 25 mm, red

#### Technical data

Contact system and fitting	2 NC
Ingress protection	IP 65 front side
Temperature range	-25 °C to +70 °C (no condensation)
Connections	galvanized, suitable to 4-pole multipoint socket connector
Switching voltage	0,02 to 25 V AC/DC
Switching current	0,1 to 1 A
Volume resistance	< 100 mW
Duration of bounce	< 10 ms
Service life	> 1,5 x 10 <sup>4</sup> switchings

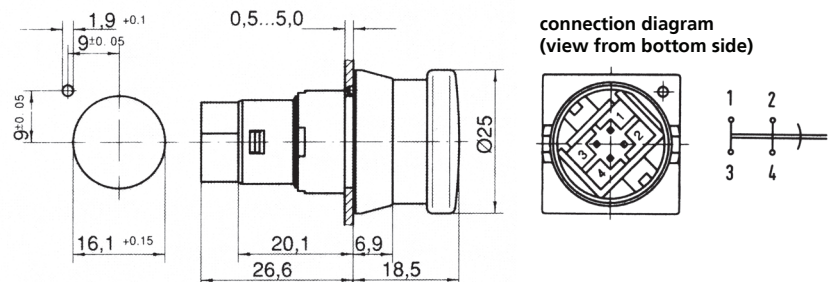

## Components

### PCB plug-socket



Order No.	Execution
<b>83.90 00 01</b>	PCB plug-socket for emergency stop button, Ø 25 mm

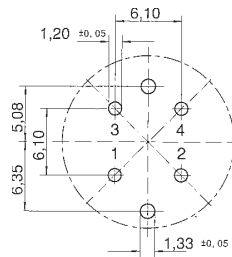

Contact fitting area

NC 1:	Pin 1 - blue
	Pin 2 - black
NC 2:	Pin 3 - blue
	Pin 4 - black

### Ribbon cable



Order No.	Execution
<b>83.90 00 02</b>	10 cm with multipoint socket connector and strip, AMP 4-pole for emergency stop button Ø 25 mm

### Emergency stop button



Order No.	Execution
<b>83.50 00 03</b>	Emergency stop button with switch unit (2NC), Ø 28 mm, red

#### Technical data

Contact system and fitting	self cleaning bridge forming contact (Ag), 2 NC
Ingress protection	IP 65 front side
Temperature range	-25°C to +70°C (no condensation)
Connections	Flachstecker 2.8 x 0.8
Switching voltage	AC: 250 V / DC: 24 V (further voltage on request)
Switching current	AC: 1,5 A / DC: 2,0 A
Volumne resistance	max. 20 mW (initial value)
Service life	≥ 3 x 10 <sup>4</sup> switchings

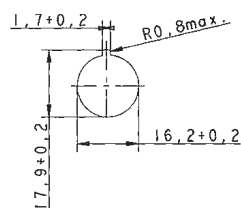
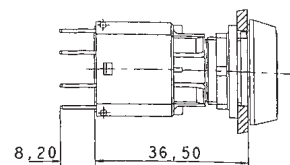
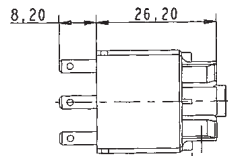
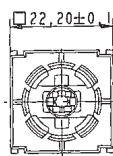

# Electro-mechanical components

## Components

### Button



Order No.	Execution
<b>83.50 00 04</b>	Emergency stop button (3NC/1NO), Ø 29 mm, red
<b>83.50 00 05</b>	Stop push button (3NC/1NO), Ø 29 mm, grey
<b>83.90 00 07</b>	Emergency stop label for command element, 16 mm, yellow, 4 speeches, 40 x 40 mm

#### Technical data

Contact system and fitting	obligation-led contacts (3 NC / 1 NO)
Ingress protection	IP 65 front side
Temperature range	-25°C to +60°C (no condensation)
Connections	soldered connection
Switching voltage (direct contact)	AC(12): 250 V / DC(12): 30 V
Switching current (direct contact)	AC(12): 3,0 A / DC(12): 2,0 A
Switching voltage (indirect contact)	AC(12): 250 V / DC(12): 30 V
Switching current (indirect contact)	AC(12): 0,6 A / DC(12): 2,0 A
Volume resistance	max. 50 mW (initial value)
Service life	≥ 1 x 10 <sup>5</sup> switchings

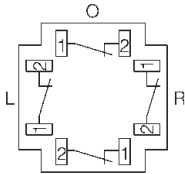

Direct contact  
 1 NC: connections right  
 2 NC: connections right and left  
 3 NC: connections right, left and above

front panel strength 0.5 to 3.7

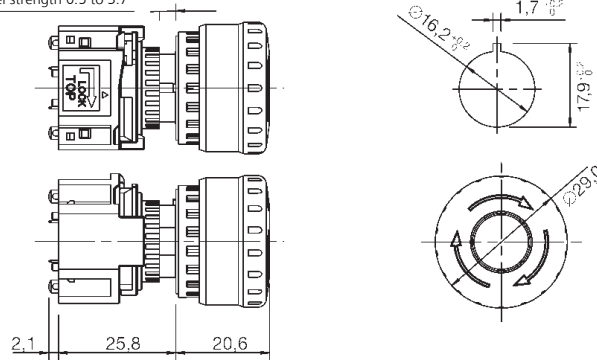

### Enabling switches



Order No.	Execution
<b>83.50 00 06</b>	3-steps enabling switches (2 changer), 80 x 22, black

#### Technical data

Contact system and fitting	2 main switches (changer)
Contact rating	30 V DC, max. 0,5 A
Ingress protection	IP 65
Temperature range	0°C to +50°C
Fullfilled standards	89/392/EWG; IEC 204-1: EN 60204/DIN VDE 0113; DIN VDE 0110: EN292

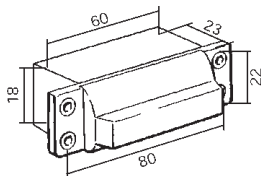

#### Connection diagram

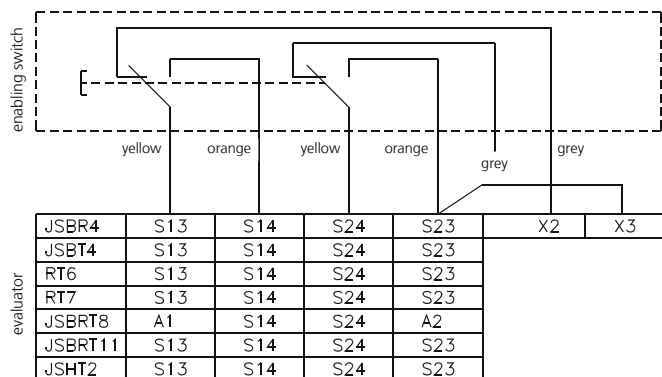

## Components

### Enabling switches

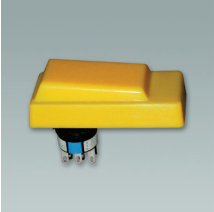

Order No. Execution

**83.50 00 07** 3-step enabling switches (2 changers), 55 x 25, yellow

#### Technical data

Contact system and fitting	2 main switches (changer)
Ingress protection	IP 65 (with rubber cap)
Temperature range	-25°C to +60°C (no condensation)
Connections	soldered condensation
Switching voltage	AC(12): 125 V / DC(12): 30 V
Switching current	AC(12): 1,0 A / DC(12): 1,0 A
Volume resistance	max. 50 mW (initial value)
Service life	≥ 1 x 10 <sup>5</sup> switchings

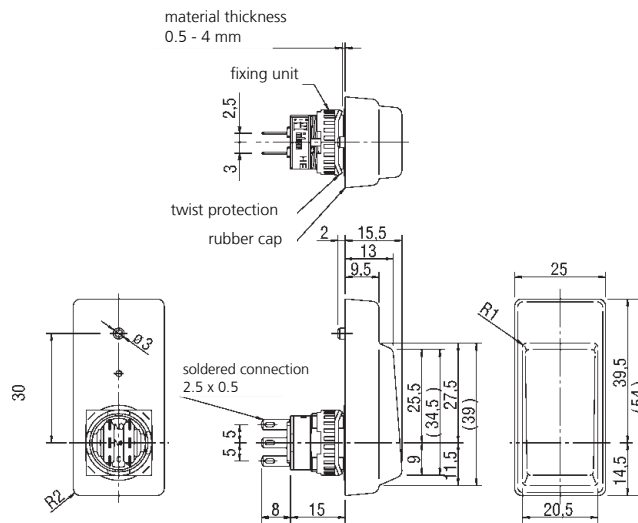
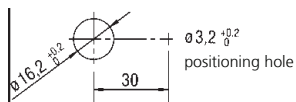

### Enabling switches



Order No. Execution

**83.50 00 08** 3-steps enabling switches (2 changer), Ø 20 mm, yellow

#### Technical data

Contact system and fitting	2 main switches (changer)
Ingress protection	IP 65 (with rubber cap)
Temperature range	-10°C to +60°C (no condensation)
Connections	soldered connection
Switch voltage	AC(12): 125 V / DC(12): 30 V
Switch current	AC(12): 0,5 A / DC(12): 1,0 A
Volume resistance	max. 50 mW (initial value)
Service life	≥ 1 x 10 <sup>5</sup> switchings

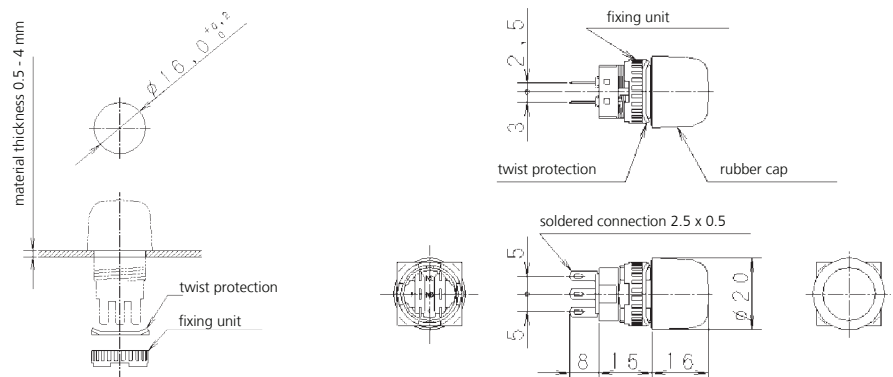

# Electro-mechanical components

## Product allocation

Products	2-step enabling switches (1NO), blue	2-step enabling switches (1NC/1NO), blue	Emergency stop button (2NC), Ø 25 mm, red	PCB-plug-socket for emergency stop button Ø 25 mm	Ribbon cable 10 cm with multipoint socket connector and strip, AMP 4-pole for emergency stop button Ø 25 mm	Emergency stop button with contact block (2NC), Ø 28 mm, red
Order No.	<b>83.50 00 10</b>	<b>83.50 00 09</b>	<b>83.50 00 02</b>	<b>83.90 00 01</b>	<b>83.90 00 02</b>	<b>83.50 00 03</b>
Taguan 130			•	•	•	
Taguan 180			•	•	•	
Taguan 230			•	•	•	
Beluga 180	•	•	•	•	•	•
Beluga 220	•	•	•	•	•	•
Beluga 380	•	•	•	•	•	•
Pilot 250	•	•	•	•	•	•
Pilot 50			•	•	•	•
Pilot 10			•	•	•	•
Pilot 20			•	•	•	•
Pilot 30			•	•	•	•
Pilot 110			•	•	•	•
Pilot 120			•	•	•	•
Pilot 130			•	•	•	•
Pilot 140			•	•	•	•
Limanda I Handle set	•	•				
Limanda I	•	•	•	•	•	•
Limanda II	•	•	•	•	•	•
Norvent	•	•	•	•	•	•

Products	Emergency stop button (3NC/1NO), Ø 29 mm, red	Stop button (3NC/1NO), Ø 29 mm, grey	3-steps enabling switches (2 changer), 80 x 22, black	3-steps enabling switches (2 changer), 55 x 25, yellow	3-steps enabling switches (2 changer), Ø 20 mm, yellow
Order No.	<b>83.50 00 04</b>	<b>83.50 00 05</b>	<b>83.50 00 06</b>	<b>83.50 00 07</b>	<b>83.50 00 08</b>
Taguan 130					
Taguan 180					
Taguan 230					
Beluga 180	•	•			
Beluga 220	•	•			•
Beluga 380	•	•			
Pilot 250	•	•	•	•	•
Pilot 50	•	•			
Pilot 10	•	•			•
Pilot 20	•	•			
Pilot 30	•	•			
Pilot 110	•	•			•
Pilot 120	•	•			
Pilot 130	•	•			
Pilot 140	•	•			
Limanda I Handle set			•		•
Limanda I	•	•	•		•
Limanda II	•	•	•	•	•
Norvent	•	•	•	•	•

ROSE Systemtechnik GmbH  
Erbeweg 13-15 | D-32457 Porta Westfalica  
Fon +49 571 50 41 0 | E-Mail [rose@rose-pw.de](mailto:rose@rose-pw.de)  
[www.rose-systemtechnik.com](http://www.rose-systemtechnik.com)



A Phoenix Mecano Company