

Frontansicht ohne Frontplatte / Front view without frontplate

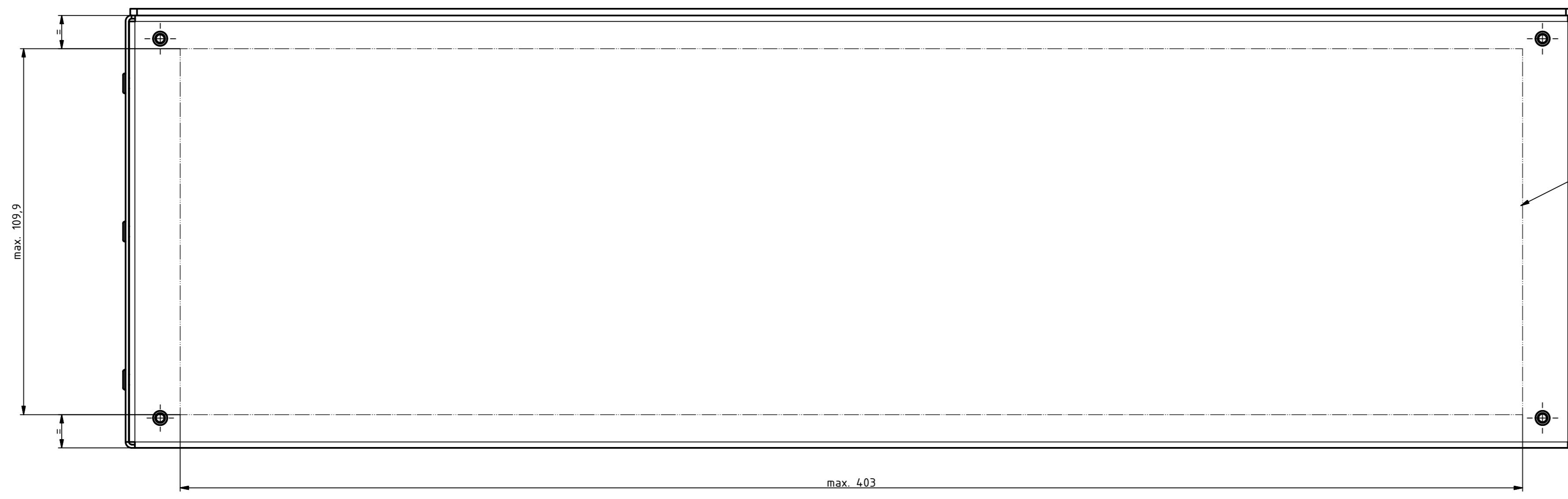

(1 : 2)
ISO-Ansicht / ISO-View

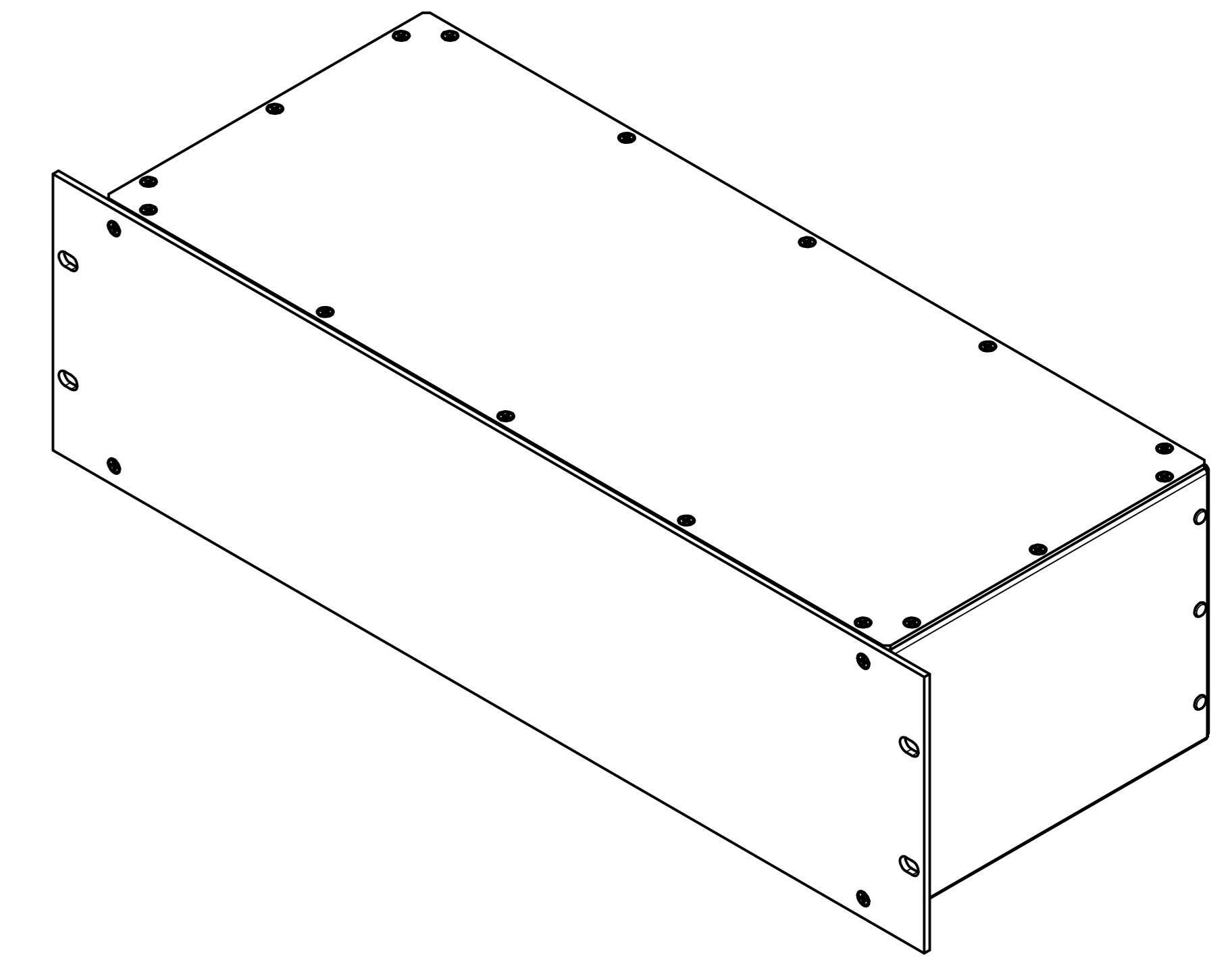

Frontansicht / Front view



ISO-Ansicht/ISO-View (1 : 2)
Ohne Deckel, Frontplatte & Schrauben /
Without lid, frontplate & screw

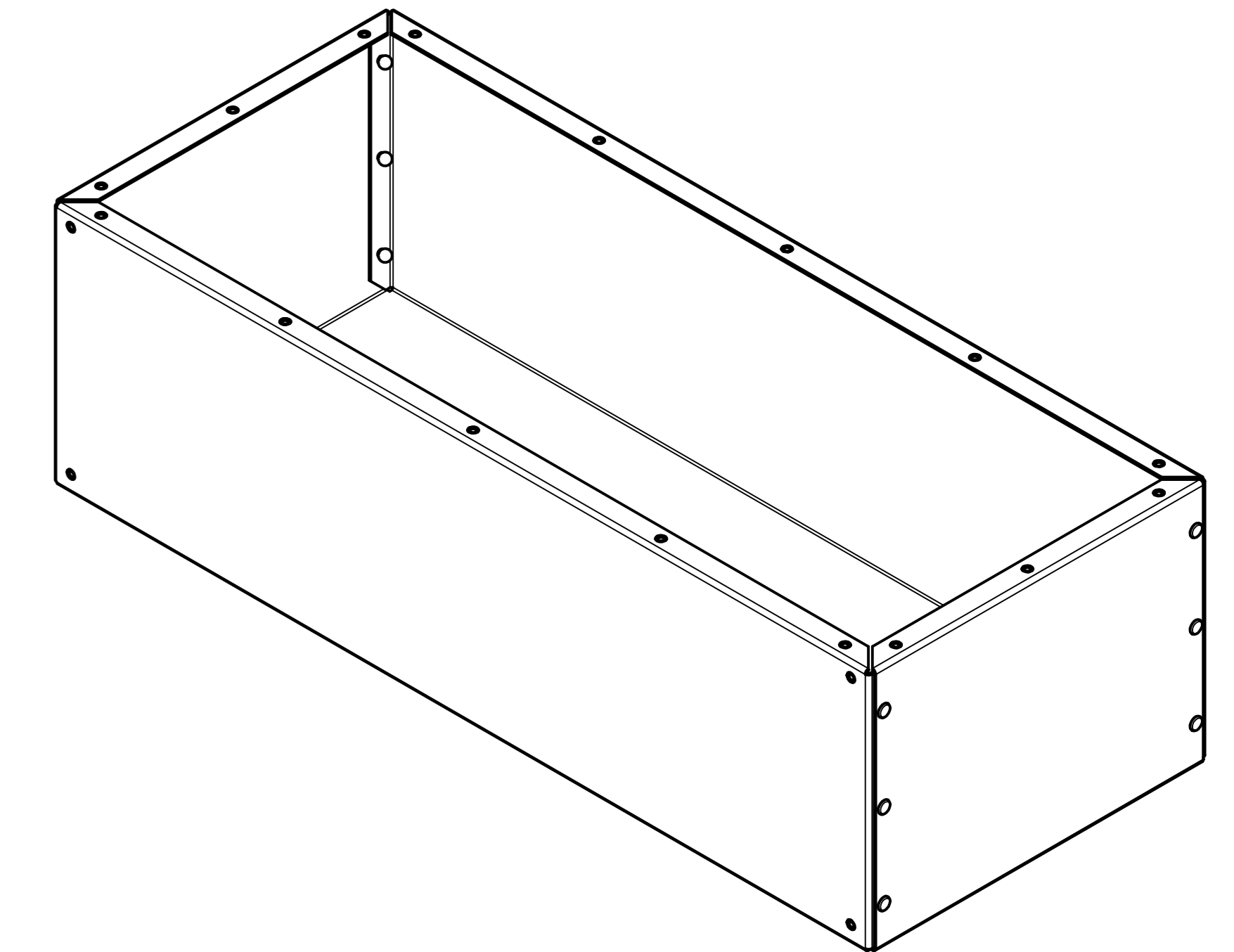

A-A (1 : 1)
Seitenansicht / Side view

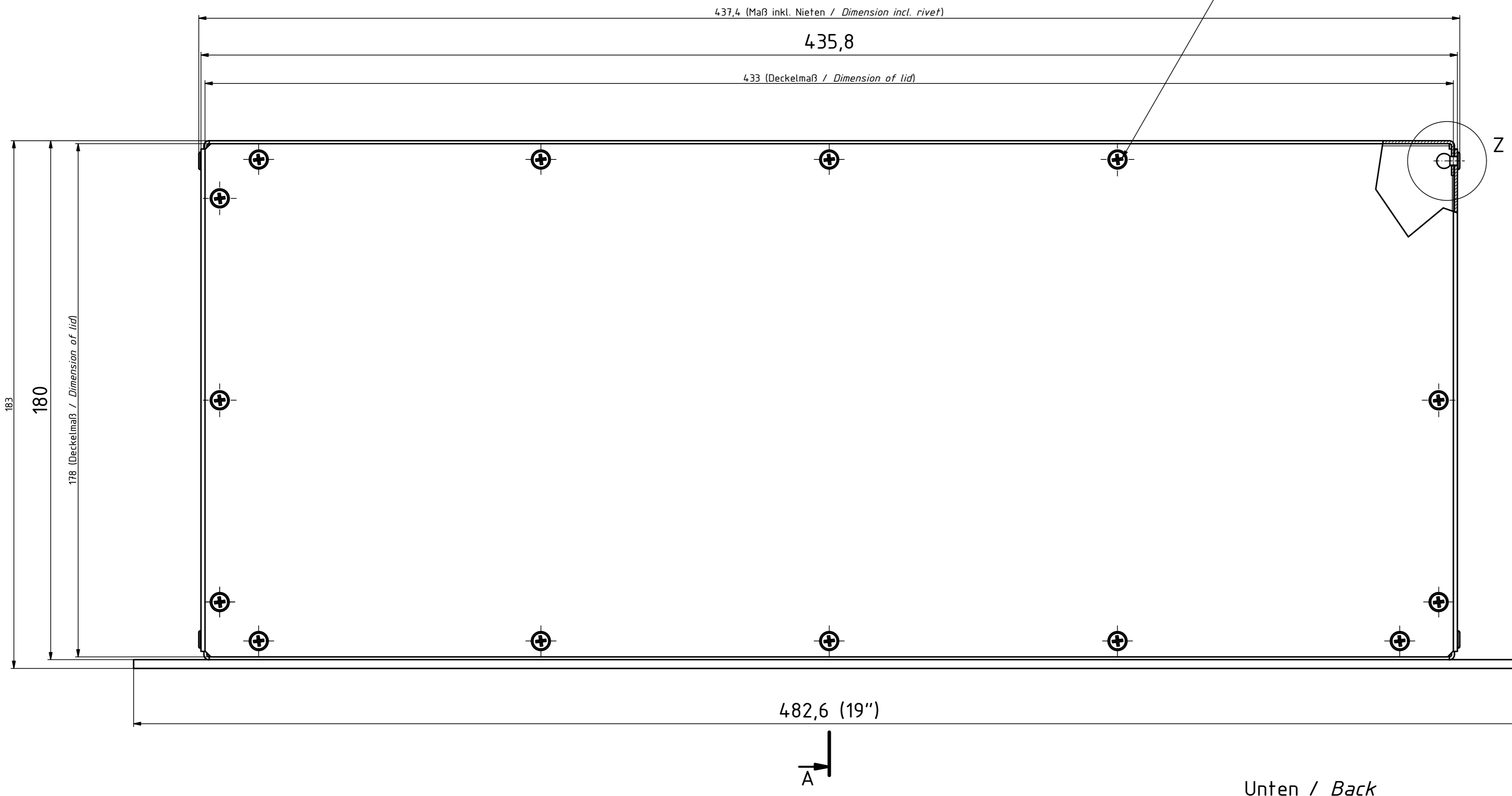
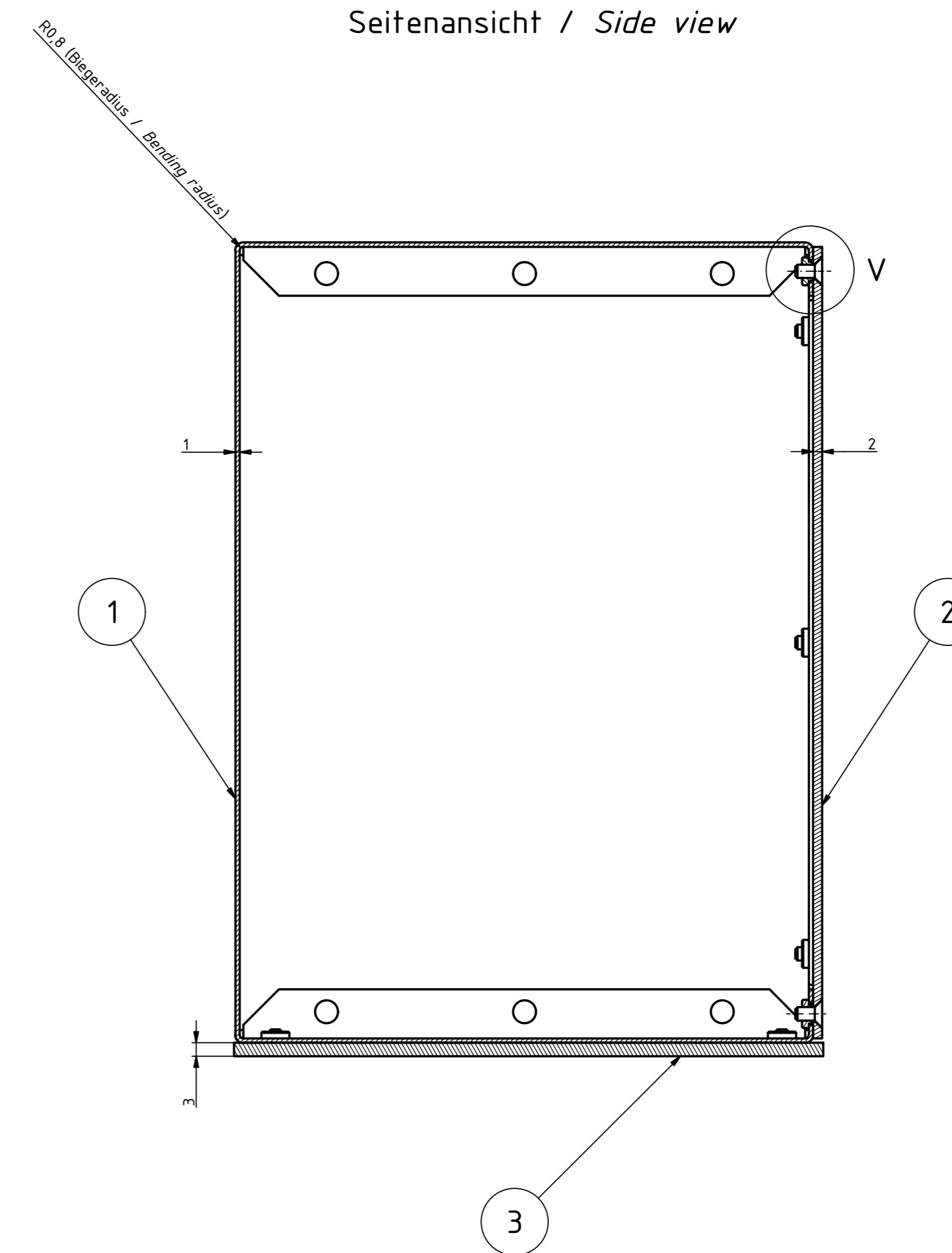

Z (2 : 1)

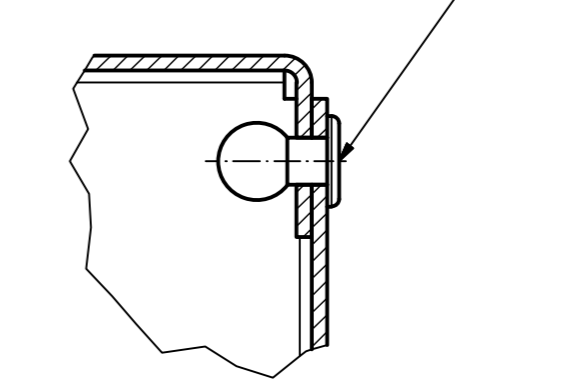

V (2 : 1)

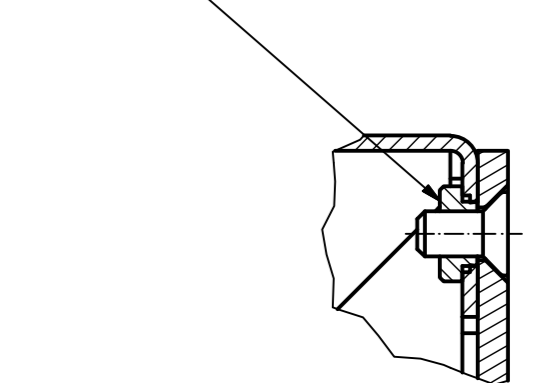

Rückansicht / Rear view

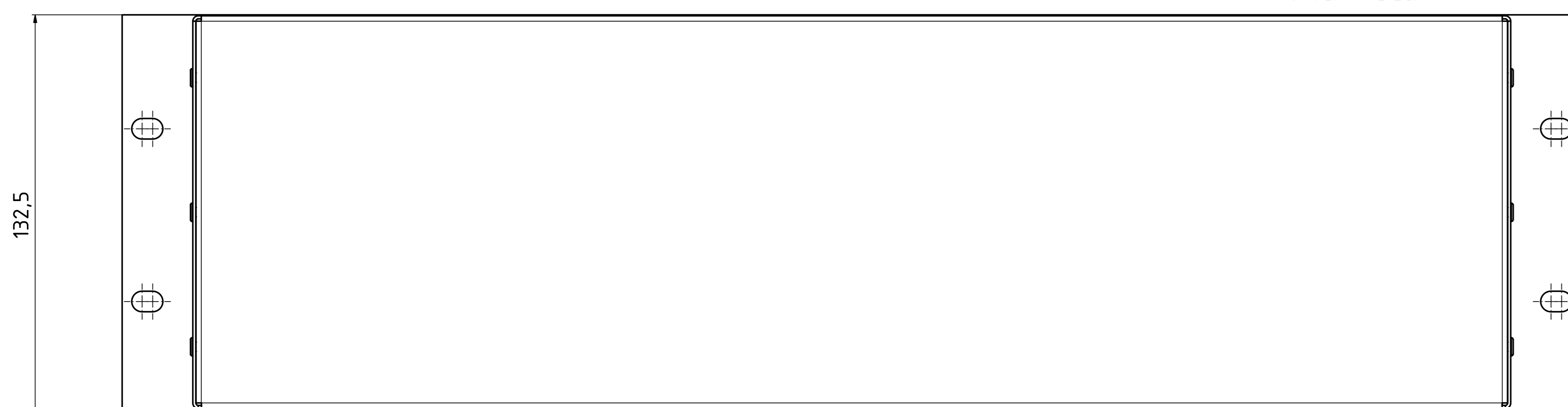

Unten / Back

Oben / Top

Stückliste / Bill of material

Pos.	St.	Modell / Model	Werkstoff / Material	Zeichnung / Drawing	Material-Nr.	Sonstiges / ect.
1	1	3HEKorpus / 3U corpus 1mm	EN AW-5754-H22-ND (Alu roh/Alu raw)	0A 5425.001.0		
2	1	3HE Deckel / 3U lid 2mm	EN AW-5754-H22-ND (Alu roh/Alu raw)	2A 5425.002.0		uml. 1mm kleiner wie Pos.1 / 1mm less than Pos.1
3	1	3HE Frontplatte / 3U frontplate 3mm	EN AW-5754-H22-EO-E6/C-0, Schnittkanten blank / Cutting edges raw aluminium	2A 5425.003.0		19"-Abmessungen (BHE) / 19" -size (IU)
4	20	KVT CLS-H3-1	Nichtrostender Stahl 18/8 (AISI 302/303) / Stainless steel 18/8 (AISI 302/303)		59000192	
5	12	BLINT 7337A AL/ST 3.0x6			59000191	Verwendung für Pos.1 / Use for Pos.1
6	20	SHR S H3X6 DIN 965	Edelstahl / Stainless steel		59000337	

Artikel-Nr. / Art.-No.:
 Werkstoff- / Material:
 Maßstab / Scale: 1:1 (1:2;2:1)
 Zeichnungs-Nr. / Drawing-No.: 0G 54.25.019.01
 Ben. Erstellt nach Vorlage / Dim.: constructed by specification

Artikelnr. / Article: IC/Z 18380
 3HE/U, 84 TE/HP, 180mm
 Grundzeichnung/Basic drawing

BOPLA
 A Phoenix Mecano Company

DISK: 2903696.idw
 Datum/Date: 25.08.2016 NR Blatt/Sheet: 1 / 1
 Datum/Date Unterschrift/Signature

geprüft / checked
 Fertigungsfreigabe / Production release

"Schutzzeichen nach DIN ISO 15026-1:2015-06, Copyright © 2015, BOPLA" / "Trade mark after DIN ISO 15026-1:2015-06, Copyright © 2015, BOPLA"